



## TNC 620

Compact Contouring Control  
for Milling, Drilling, and  
Boring Machines



# Contents



**TNC 620  
with touchscreen**



**TNC 620  
with operating keys and  
alphanumeric keyboard**



The functions and specifications described in this brochure apply to the TNC 620 with NC SW 81760x-08

## The TNC 620...

Where can it be used?	<b>Compact and versatile</b> The right control for milling, drilling, and boring machines	<b>4</b>
What does it look like?	<b>Intuitive and user-friendly</b> State-of-the-art multitouch operation Highly practical user interface	<b>6</b>
What can it do?	<b>Fast and reliable machining at high contour fidelity</b> Optimal tool guidance by the TNC 620	<b>10</b>
	<b>Machining with five axes</b> Swivel head and rotary table controlled by the TNC 620	<b>12</b>
	<b>Minimize setup times</b> The TNC 620 makes setup easy	<b>14</b>
	<b>Automated machining</b> The TNC 620 measures, manages, and communicates Pallet management and serial machining	<b>16</b>
How is it programmed?	<b>Programming, editing, and testing</b> A full range of possibilities with the TNC 620 Graphical support in any scenario	<b>18</b>
	<b>Programming in the shop</b> Straightforward function keys for complex contours Programing free contours and Data Matrix codes Practical cycles for recurring operations Practical turning cycles (option) Practical functions for grinding and dressing (option) Reusing programmed contour elements Rapid availability of all information	<b>20</b>
	<b>Intelligent machining</b> Dynamic Precision Active Chatter Control option (ACC) Optimized roughing processes with OCM (option)	<b>26</b>
What accessories are there?	<b>Open to outside information</b> StateMonitor: collect and evaluate machine data Uniformly digital job management with Connected Machining Processing CAD files with the TNC 620 The TNC 620 programming station	<b>31</b>
	<b>Positioning with an electronic handwheel</b> Fine motion control of axes	<b>37</b>
	<b>Workpiece measurement</b> Setup, preset setting, and measuring with touch trigger probes	<b>38</b>
	<b>Tool measurement</b> Measuring length, radius, and wear inside the machine	<b>39</b>
	<b>Inspecting and optimizing machine accuracy</b> Easy calibration of rotary axes with KinematicsOpt (option)	<b>40</b>
... At a glance	<b>Overview</b> Specifications, user functions, accessories, options, comparison of controls	<b>41</b>



## Compact and versatile

The right control for milling, drilling, and boring machines

For more than 40 years, TNC controls from HEIDENHAIN have proven themselves every day on milling machines, machining centers, and drilling machines. Over this period, they have been continually further developed, with focus placed on an operating approach tailored to the needs of the machine operator.

These principles can also be found in the TNC 620: shop-oriented programmability with graphical support, many practical cycles, and an operational design that you are familiar with from other HEIDENHAIN controls.

**The TNC 620 is compact and easy to read.** The TNC 620 is a compact, versatile contouring control with up to five controlled axes and a controlled spindle. Thanks to its user-friendly operation and scope of features, it is especially suited for use on universal milling, drilling, and boring machines for:

- Series and single-part production
- Tool making
- Machine building
- Research and development
- Prototypes and pilot plants
- Repair departments
- Training and education facilities

### Multitouch operation

The TNC 620 comes with a keyboard and touchscreen that puts zooming, rotating, and dragging all at your fingertips for fast and easy operation of the TNC 620.



### Shop-oriented programming

You program conventional milling and drilling operations right on the machine using the shop-oriented Klartext conversational programming language from HEIDENHAIN. With helpful dialog guidance and informative visual aids, the TNC 620 provides optimal programming support.

For standard machining operations and even complex applications, a wealth of practical machining and coordinate transformation cycles are at your beck and call.

### Offline programming

The TNC 620 is easy to program remotely as well. Its Fast Ethernet interface ensures extremely short upload times, even for long programs. In addition, data can be transferred quickly and easily via the USB interface.

### CAD viewer as standard

Display your CAD data in the .step or .iges format directly on the TNC 620. The standard integrated CAD viewer can open many common 3D formats and display them on the TNC 620 screen.

### Finely detailed graphics

Thanks to the high-resolution program verification graphics of the TNC 620, you can exactly evaluate the result of milling or drilling processes even before the actual machining operation.

### Advanced Dynamic Prediction (ADP)

The TNC 620 offers its ADP function for demanding milling operations. This optimizes the motion control for all feed axes. With the TNC 620, you achieve even higher surface quality and contour fidelity.

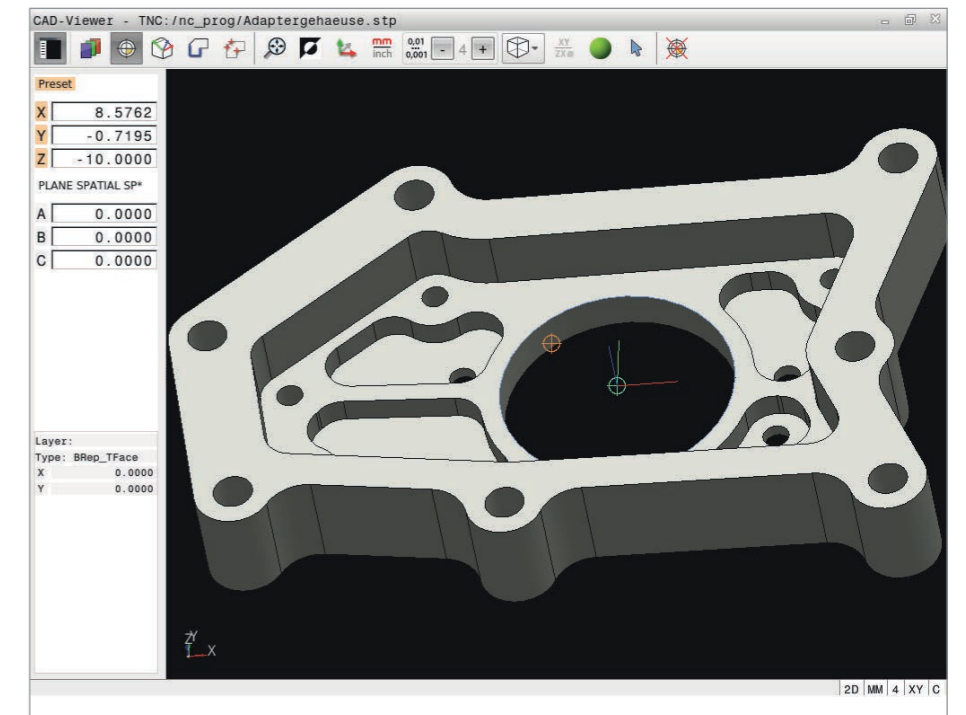
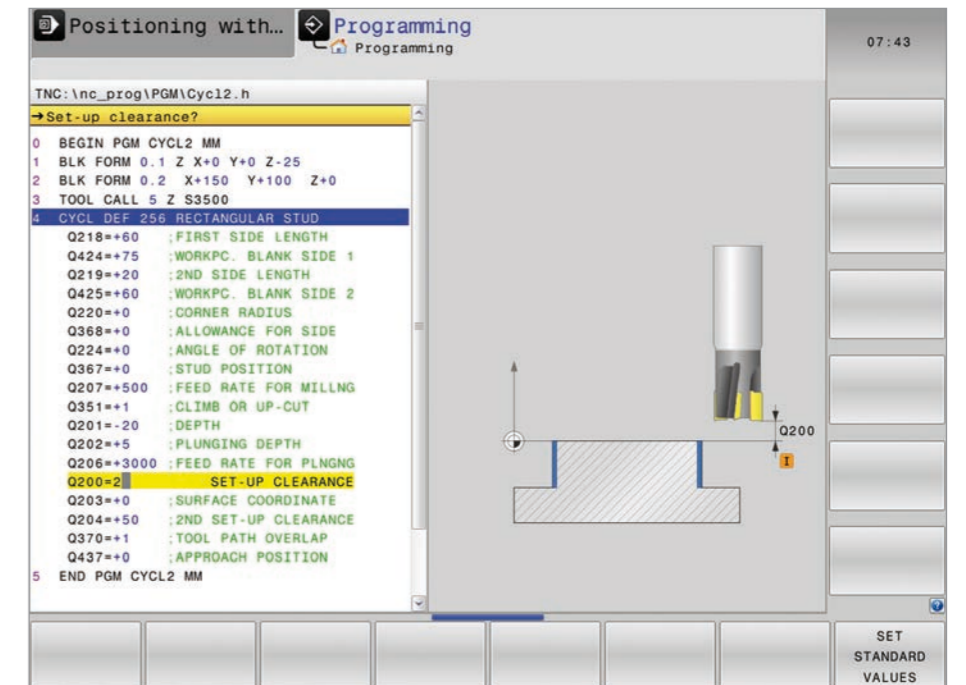

# Intuitive and user-friendly

## State-of-the-art multitouch operation

### The screen

In a clear format, the 19-inch screen displays all of the information you need for programming, operating, and checking the control and the machine, including program blocks, tips, and error messages.

**Extended Workspace Compact** offers even more information: alongside the main window with its usual control interface there is an additional window for displaying any external application. You can also use a **split screen** in the main window to display your NC blocks on one side and the graphical image and status display on the other. While the program is running, **status displays** are available that inform you about the tool position, current program, coordinate transformations, and more. The TNC 620 even displays the current machining time.

### Intuitive touchscreen operation

The conventional operating approach of the TNC has proven itself over many years, with operators around the world using the TNC's dialog keys, navigation keys, and soft keys. For even more innovative and user-friendly operation, the TNC 620 now also comes in a touchscreen version. This approach combines the proven benefits of the HEIDENHAIN controls with a new method that uses tapping, swiping, and dragging gestures.

### Easy to operate

The TNC 620 can be conveniently operated with a connected mouse, but many machine shops lack an adequate surface for a mouse. A touchscreen, however, eliminates the need for additional workspace for input devices and makes everyday operation of the TNC 620 even easier thanks to swiping, direct selection of operating elements, and menu navigation. The touchscreen is particularly helpful when using the CAD Import function, allowing you to rapidly zoom, drag, or select with simple gestures.

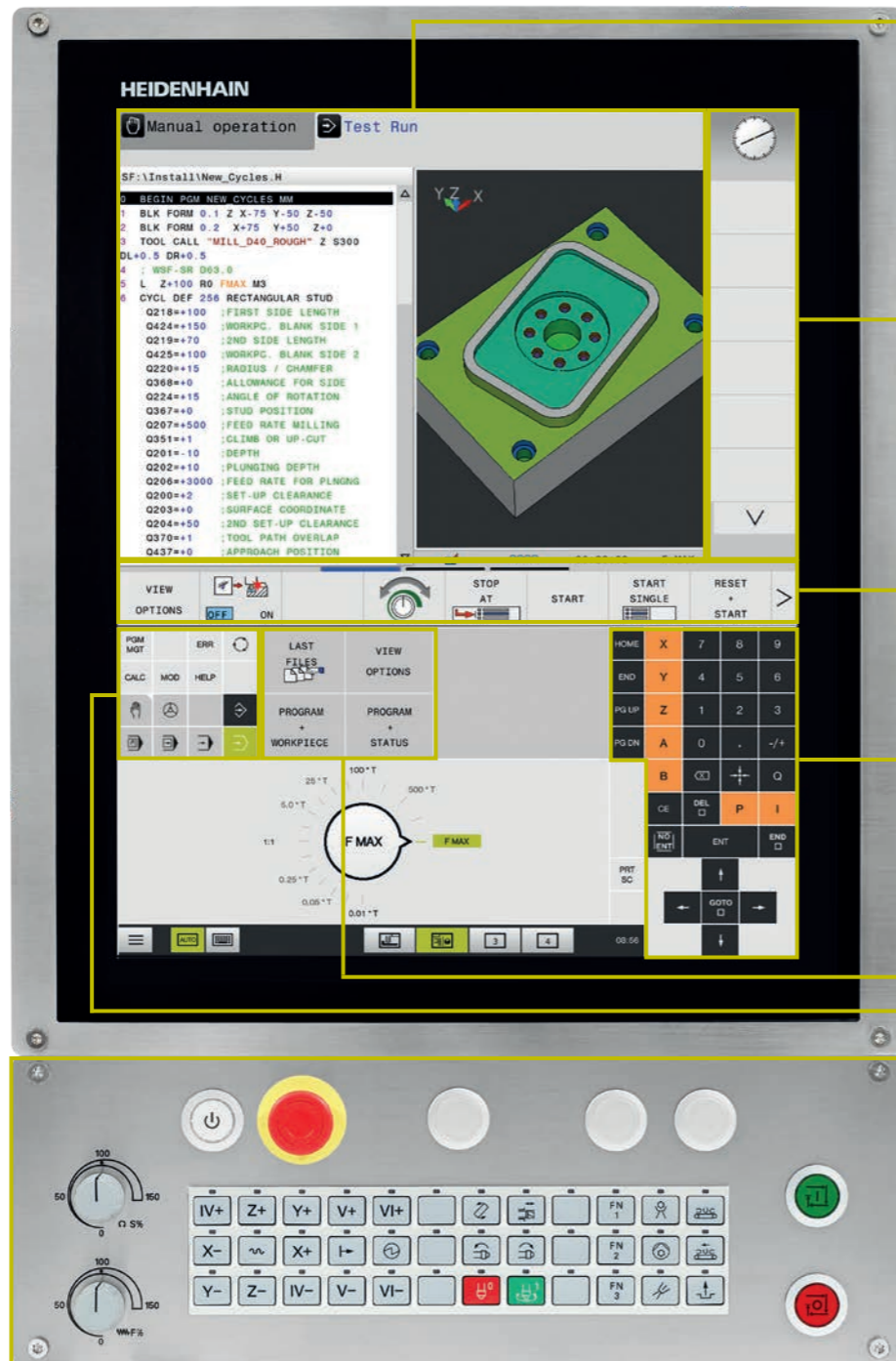

**Main window** for displaying two operating modes, the program, the graphical image, and the machine status

**PLC soft keys** for machine functions

Self-explanatory **soft keys** for NC programming

**Axis keys, numeric keypad, and navigation**

**Quick access menu**

**Function keys** for programming modes, machine operating modes, TNC functions, management, and navigation

**Machine operating panel** with snap-on keys and override potentiometers for feed rate and spindle speed

### Practical touchscreen

With an IP54 rating, the touchscreen is designed to handle harsh shop conditions thanks to these characteristics:

- Dust-protected
- Splash-proof
- Scratch-proof

To clean your screen, simply select the "Touchscreen Cleaning" mode. This locks the screen to prevent unintended operation.

### Gestures for multi-touch operation

The screen of the TNC 620 can be operated with gestures already familiar to you from your smartphone or tablet. For example, you can zoom in or out with two fingers, or swipe to rapidly navigate through programs, menus, and the soft-key row.

Symbol	Gesture
	Tap
	Double tap
	Long press
	Swipe
	Drag
	Two-finger drag
	Spread
	Pinch

### Leading-edge design

The user interface of the TNC 620 boasts a sleek outer appearance with gently rounded edges, color gradients, and a pleasingly uniform font. The different screen areas are clearly delineated, and the operating modes are indicated by special operating mode symbols.

To help you evaluate the priority of error messages, the TNC 620 displays them in color-coded categories. A color-coded warning triangle is also displayed.

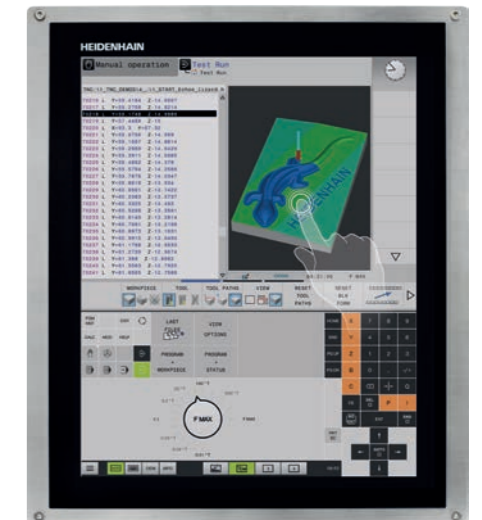



# Intuitive and user-friendly

## Highly practical user interface

The key to safe and low-fatigue work is having an intuitive screen layout and an ergonomic, well-arranged keyboard. Although HEIDENHAIN has been adhering to these principles for a long time, the TNC 620 offers a number of features that make working with the control even simpler and easier than before.

### The smartSelect functions overview

With dialog support, you can now readily select functions that were previously available only via soft key structures. As soon as you open smartSelect, you are shown a tree structure with all of the subordinate functions that can be defined in the control's current operating state. The TNC also displays integrated help on the right-hand side of the smartSelect window. When you make a selection with the cursor or per mouse click, you immediately receive detailed information about the function. The smartSelect feature is also available for the definition of machining cycles, touch probe cycles, special functions (SPEC FCT), and for parameter programming.

### Color-structured programs

The content of a program line can be quite extensive:

- Line number
- Program function
- Input value
- Comment

To make sure you always keep an overview even in complex programs, the TNC 620 displays the individual program elements in different colors. This allows you, for example, to see at a glance where the editable input values are.

### Universal table editor

Regardless of whether you are editing a tool, preset, or pallet table, the layout, method of operation, and functions of the table editor are always the same.

### Info line

In the info line, the TNC 620 helps you orient yourself by displaying the respective status of the submode.

### MOD function

The additional MOD operating mode offers a wide variety of possible settings in a standardized layout, regardless of the operating mode.

### User administration

The user administration feature of the TNC 620 lets you define various roles and access rights for users, ensuring that each user can act only within his assigned rights. This helps prevent the unintentional or unauthorized deletion of files and system file content. Many functions are also available only with the corresponding permissions. Consequently, the user administration feature of the TNC 620 not only provides greater data security but also increases machine operating safety.

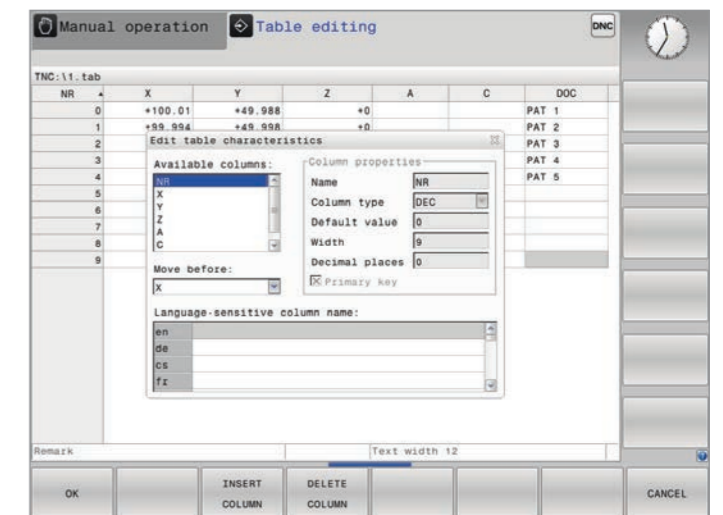
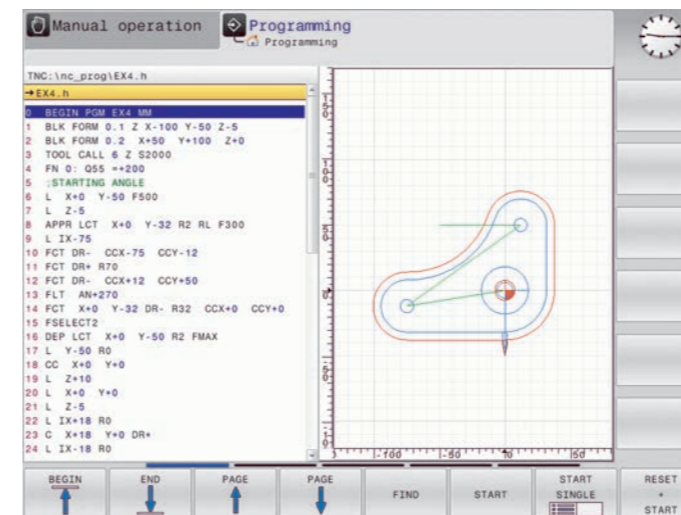
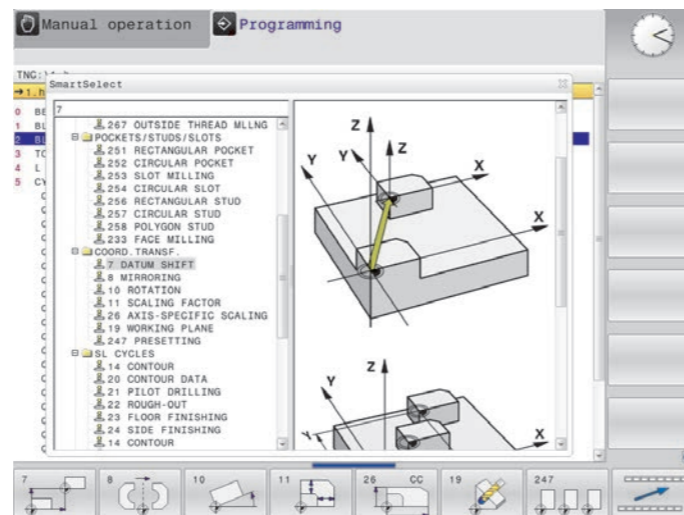
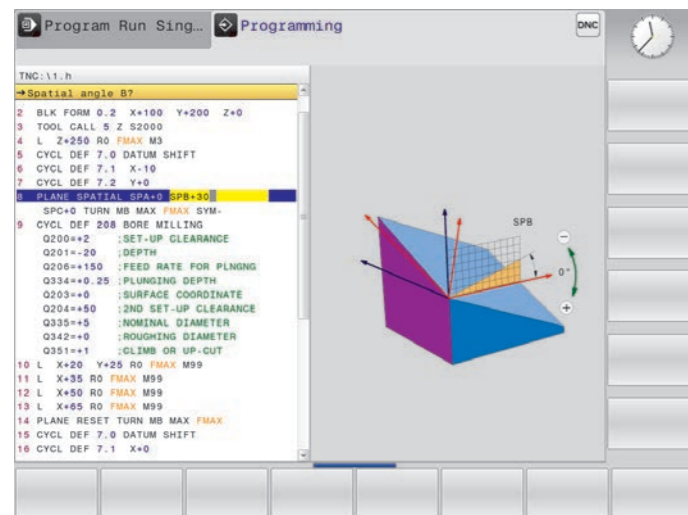

# Fast and reliable machining at high contour fidelity

## Optimal tool guidance by the TNC 620

### High contour fidelity and surface quality

TNC controls from HEIDENHAIN are known for their **low-jerk and speed/acceleration-optimized motion control**, enabling optimized surface quality and workpiece accuracy. With the TNC 620, you are able to leverage the latest technological developments. The TNC 620 anticipates and thinks along with you, dynamically calculating the contour ahead of time. In addition, special filters suppress machine-specific natural frequencies.

With its **Look Ahead** function, the TNC 620 recognizes directional changes ahead of time and adapts the traversing speed to the shape of the contour and the surface to be machined. You simply program the maximum machining speed as the feed rate and, in **Cycle 32 TOLERANCE**, enter the maximum permissible deviations from the ideal contour. The TNC 620 automatically adapts the machining to the tolerance that you define. This method prevents contour defects.

### Advanced Dynamic Prediction (ADP)

expands upon the previous look-ahead calculation of the permissible maximum feed rate profile. ADP compensates for differences in the feed rate profiles resulting from the point distribution on neighboring paths, especially in NC programs originating from CAM systems. Among other benefits, this results in particularly symmetrical feed rate behavior on the back-and-forth paths during bidirectional finish milling, as well as very smooth feed rate curves on neighboring milling paths.

### Fast machining and computing processes

With a short block-processing time of at most 1.5 ms, the TNC 620 can run fast look-ahead calculations for optimal use of the machine's dynamic parameters. Functions such as ADP and Look Ahead therefore ensure not only high contour fidelity and surface quality but also optimize the machining time.

One basis for the TNC 620's high speed is its **uniformly digital control design**. This includes the integrated digital drive technology from HEIDENHAIN as well as digital interfaces connecting all of the control components with each other:

- Control components via HSCI (HEIDENHAIN Serial Controller Interface)
- Encoders via EnDat 2.2

As a result, exceptionally high feed rates can be implemented. In the process, the TNC 620 is capable of interpolating up to five axes at the same time. To attain the required cutting speeds, the TNC 620 can digitally control spindle speeds of up to **100000 rpm**.

The TNC 620's powerful 5-axis machining capability even lets you economically manufacture complex 3D contours. Programs for such contours are usually created offline with CAM systems and typically contain numerous short line blocks that are transferred to the control. With its short block-processing time, the TNC 620 quickly executes even complex NC programs. The control's computing power can handle complex look-ahead calculations in simpler NC programs as well. Thus, regardless of the data volume of the NC programs from your CAM system, the TNC 620 will machine the workpiece to near-perfect conformity with your program.

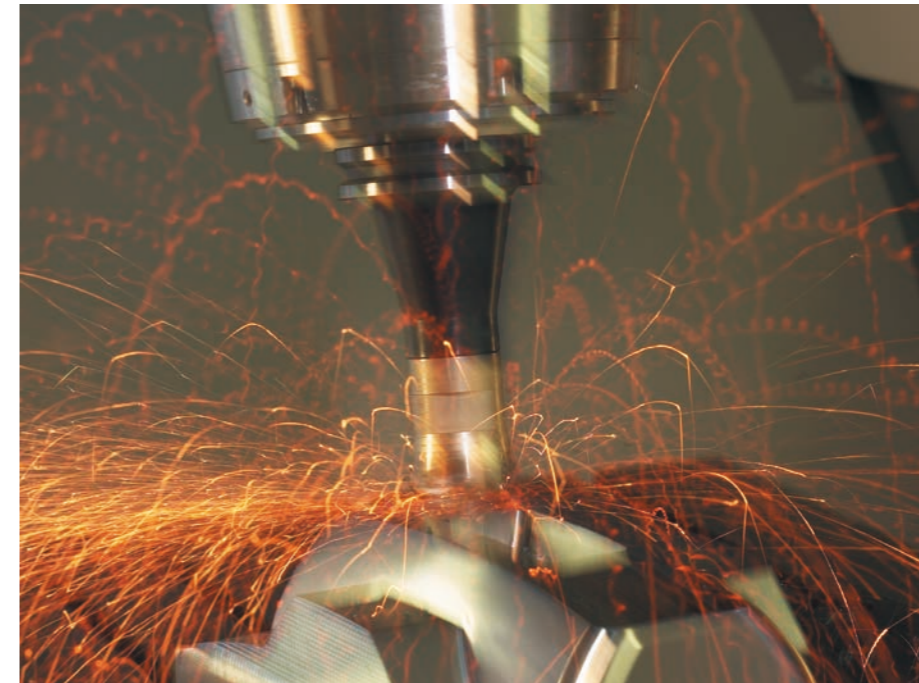



# Machining with five axes

## Swivel head and rotary table controlled by the TNC 620

Many five-axis operations that initially appear to be highly complex can be broken down into common 2D movements that have been tilted about one or more rotary axes or wrapped around a cylindrical surface. In order for you to create and edit such programs quickly and easily without a CAM system, the TNC supports you with helpful functions.

### Tilting the working plane\* (option 8)

Programs for contours and holes on inclined surfaces are often extremely complex and require time-consuming computing and programming work. But the TNC 620 can save you a great deal of programming time. You simply program the machining operation as usual in the main plane (e.g., in XY); the machine then performs the operation in a tilted plane.

The PLANE function makes it easy for you to define a tilted working plane: tilted working planes can be specified in seven different ways depending on the information available in the workpiece drawing. Help images support you during program entry.

You can also use the PLANE function to define the positioning behavior during tilting to avoid unpleasant surprises when the program is run. The settings for defining the positioning behavior are identical for all PLANE functions, making operation much easier.

\* The machine and TNC must be adapted for these functions by the machine manufacturer.



### Cylinder surface machining\* (option 8)

The programming of contours made up of straight lines and circles on cylindrical surfaces for rotary tables is no problem with the TNC 620. You simply program the contour in the plane of an unrolled cylinder surface. The TNC 620 then performs the machining operation on the cylindrical surface of the cylinder.

The TNC 620 features four cycles for cylindrical surface machining:

- Slot milling (the slot width and tool diameter are equivalent)
- Guide-groove milling (the slot width is greater than the tool diameter)
- Ridge milling
- Outside contour milling

\* The machine and TNC must be adapted for these functions by the machine manufacturer.



### Manual axis motion in the tool direction on 5-axis machines

Correct tool retraction is very important in five-axis machining. The virtual tool axis function provides assistance by allowing you to move the tool in the direction of the tool axis using external direction keys or a handwheel. This function is especially useful if you want to

- retract the tool in the direction of the tool axis during an interruption of a five-axis machining program,
- use the handwheel or external direction keys to perform an operation in Manual mode with an inclined tool, or
- move the tool with the handwheel in the active tool axis direction during machining.

### Feed rate for rotary tables in mm/min\* (option 8)

By default, the feed rate of rotary axes is programmed in degrees/min. However, the TNC 620 can interpret this feed rate in mm/min as well. The feed rate at the contour is then independent of the distance of the tool center point from the center of the rotary axis.

### Polar kinematics

With polar kinematics, the motions in the working plane are performed by one linear axis and one rotary axis. This greatly increases the machining operations possible on machines which have only two linear axes. For example, front-face operations become possible on rotary and cylindrical grinding machines. And on milling machines, suitable rotary axes can replace various linear axes, for example when working on very large surfaces on large machine tools.

# Minimize setup times

The TNC 620 makes setup easy

Before machining can begin, the workpiece must first be clamped, the machine must be set up, the position of the workpiece in the machine must be determined, and the preset must be set. This is a time-consuming but indispensable procedure because any error directly reduces the machining accuracy. Particularly in small and medium-sized production runs, as well as in the case of very large workpieces, setup times become a significant factor.

The TNC 620 features application-oriented, real-world setup functions that support the user, help reduce non-productive time, and enable overnight, unattended production. In conjunction with the **touch probes**, the TNC 620 offers numerous probing cycles for automatic workpiece setup, setting the preset, and measuring workpieces and tools.

## Fine manual axis control

During setup, you can use the axis-direction keys to move the machine axes manually or with an incremental jog. A simpler and more reliable way, however, is to use the electronic handwheels from HEIDENHAIN. With these handwheels, you are always close to the action, enjoy a close-up view of the setup process, and can control the infeed responsively and precisely.

## Adapting the probing speed

In many cases, the workpiece must be probed at unseen positions or in cramped spaces, and the standard probing feed rate is usually too fast for this. In such situations, you can use the override knob to change the feed rate during probing without affecting the accuracy.

## Workpiece alignment (option 17)

The HEIDENHAIN touch probes and probing functions of the TNC 620 reduce the need for tedious manual alignment of the workpiece:

- You start by simply clamping the workpiece in any position.
- The touch probe probes a surface to determine the amount of workpiece misalignment.
- The TNC 620 subsequently compensates for the misalignment by performing a "basic rotation," in which either the NC program is executed at the ascertained angle of rotation or the rotary table is turned in order to correct the misalignment.
- The TNC 620 offers manual, automatic, and semiautomatic cycles for compensating for misalignments in two or three dimensions

## Setting presets

A preset allows you to assign a defined value displayed by the TNC to any position on the workpiece. Finding this point quickly and reliably reduces non-productive time and increases machining accuracy. The TNC 620 features probing cycles for automatically setting presets. Ascertained presets can be saved as follows:

- Using the preset management
- In a datum table
- Through direct setting of the display

## Preset management with the preset table

Preset management enables flexible machining, shorter setup times, and higher throughput. Setting up your machine is greatly simplified.

In preset management, you can save **any number of presets** and assign an individual basic rotation to each one. In order to permanently save fixed presets in the machine's workspace, you can also write-protect individual lines.

There are three possibilities for rapidly saving the presets:

- Via a soft key in Manual mode
- Via the probing functions
- With the automatic probing cycles

## Saving datums

Datum tables let you save positions or measured values from the workpiece. Datums are always defined relative to the active preset.

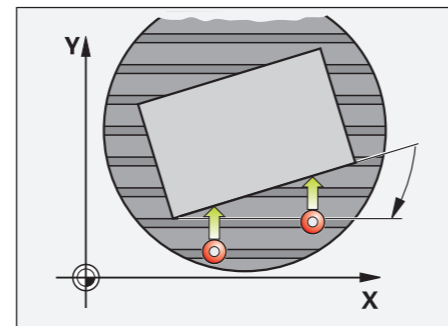
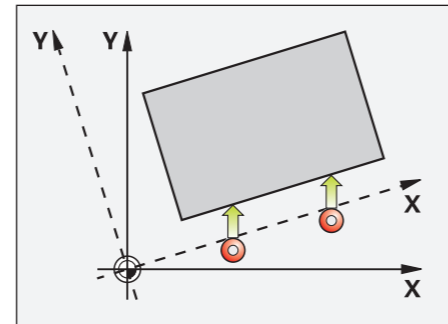

**Workpiece misalignment compensated for** by rotating the coordinate system or rotating the table

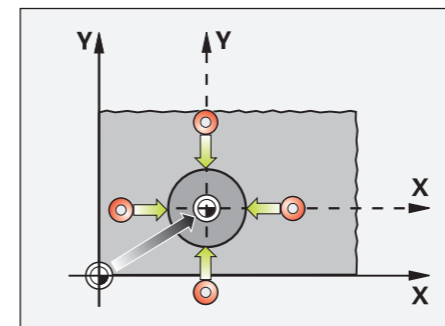
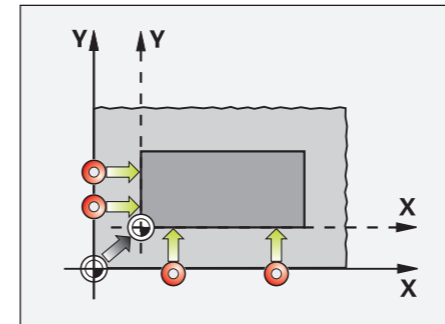

**Setting a preset** at a corner, for example, or in the center of a circular stud

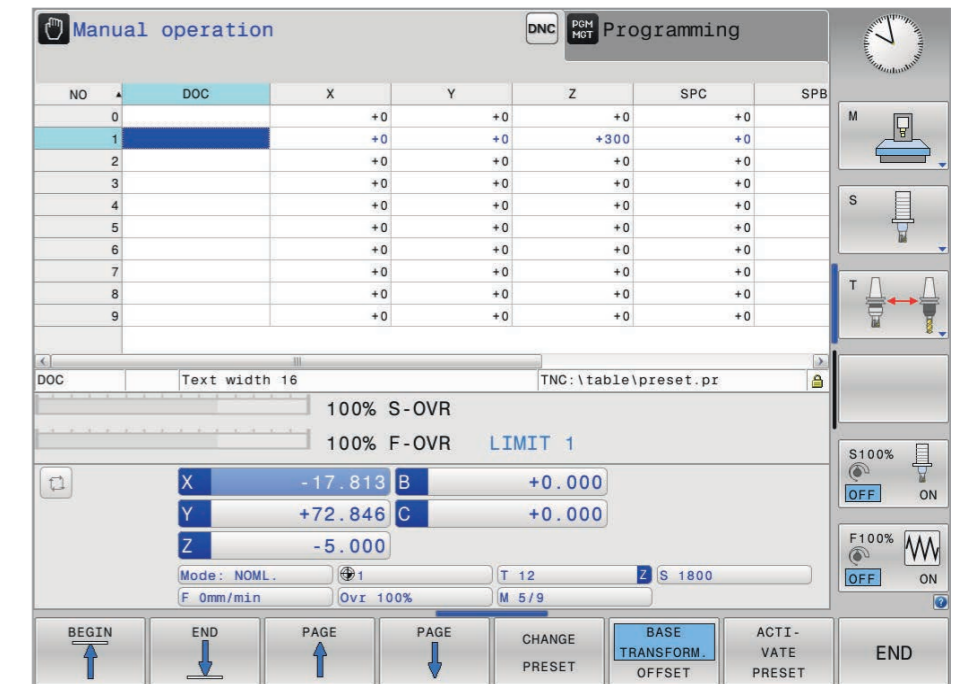



# Automated machining

The TNC 620 measures, manages, and communicates

The requirements gap between machining centers and typical tool and moldmaking machines is becoming ever narrower. Of course, the TNC 620 is also very capable of controlling automated manufacturing processes. It features the necessary functionality to initiate the proper machining operation in concatenated machining scenarios with individual workpieces in any workholding arrangement.

## Tool management

For machining centers with an automatic tool changer, the TNC 620 offers a central tool memory area for numerous turning tools. This tool memory area is a freely configurable file that can be optimally adapted to your needs. You can even have the TNC 620 manage your tool names. The control prepares the next tool change while the current tool is still cutting. This significantly reduces the non-cutting time required for tool changes.

With the Expanded Tool Management option, the control shows only the required input fields regardless of the selected tool type. Any data can also be graphically depicted.\*

\* The machine must be adapted for this function by the machine manufacturer.



## Inspecting workpieces for proper machining and dimensional accuracy (option 17)

The TNC 620 features numerous measuring cycles for inspecting the geometry of machined workpieces. This requires inserting a touch probe from HEIDENHAIN into the spindle in place of the tool. This allows you to do the following:

- Recognize a workpiece and call the appropriate part program
- Check whether all machining operations were conducted correctly
- Determine infeeds for finishing
- Detect and compensate for tool wear
- Inspect workpiece geometry and sort parts
- Log measured data
- Ascertain the machining trend
- Check tolerances and configure various reactions, such as an error message

## Milling-tool measurement and automatic compensation of tool data (option 17)

In conjunction with the TT tool touch probe, the TNC 620 lets you automatically measure milling tools in the machine. The TNC 620 then stores the determined values, such as tool length and radius, in its tool memory. By inspecting the tool during machining, you can quickly detect wear or breakage for preventing scrap and rework. If the measured deviations lie outside the specified tolerances or if the monitored tool life has been exceeded, the TNC 620 locks the tool and automatically inserts a replacement tool.

# Pallet management and serial machining

## Pallet Management (option 22)

Pallet management functionality lets you automatically machine workpieces in any order. Upon insertion of the pallet, the correct machining program and preset are automatically selected. You can also apply coordinate transformations and measuring cycles in the part programs.

## Batch Process Manager (option 154)

Batch Process Manager is a powerful function for pallet machining and serial production. With its intuitive user interface, you can plan your production process and receive important information about upcoming machining operations.

Batch Process Manager automatically checks for missing tools, insufficient tool life, and required manual tool changes. The results are displayed in the status overview.

Batch Process Manager shows the following information in advance:

- The machining sequence
- The time of the next manual intervention
- The program duration and run time
- Status information about the preset, tool, and program

## Tool-oriented machining (option 22)

In tool-oriented machining, a single machining step is performed on all of a pallet's workpieces before moving to the next machining step. This keeps the number of tool changes to a minimum and significantly shortens the machining time.

The TNC 620 supports you with convenient fillable forms that allow you to assign a tool-oriented operation to a pallet with multiple workpieces. As always, you still write the machining program in the normal workpiece-oriented sequence.

You can also use this function even if your machine does not support pallet management. In this case, you simply define the position of the workpiece on the machine table in the pallet file.

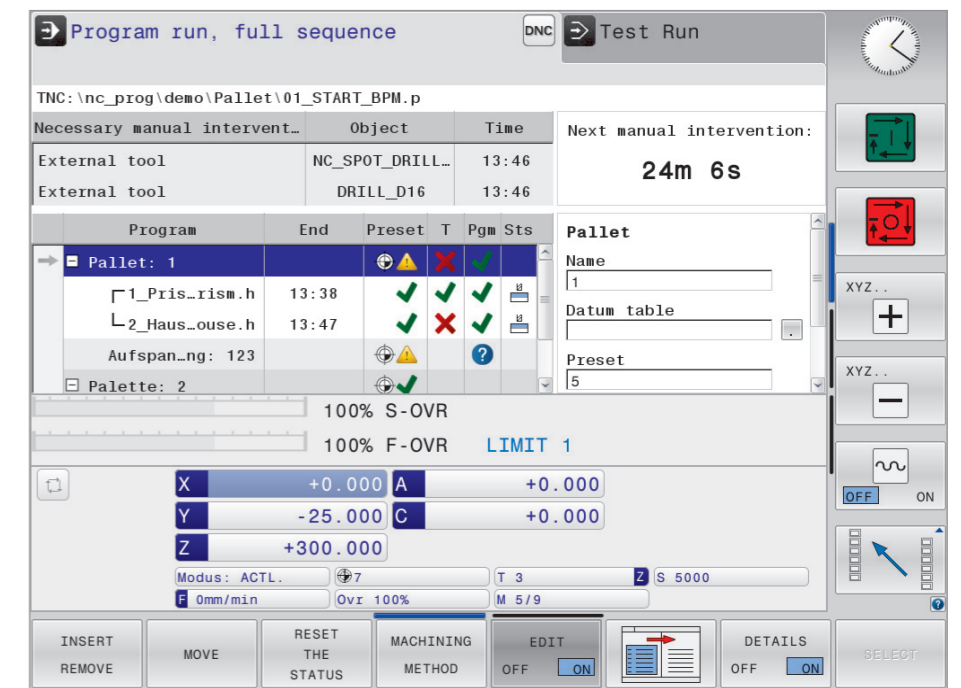
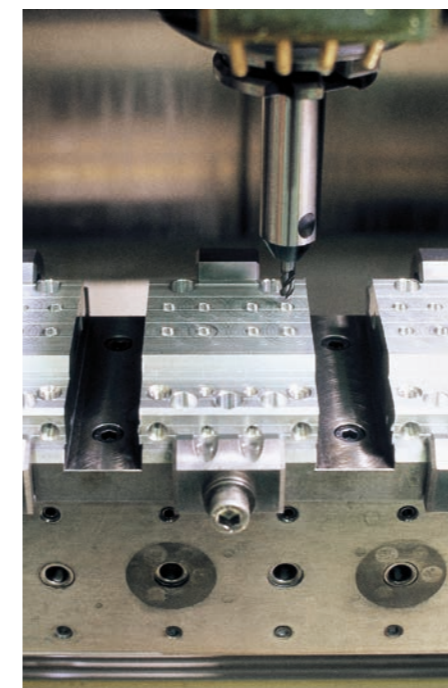

# Programming, editing, and testing

A full range of possibilities with the TNC 620

Graphical support in any scenario

Besides being universally deployable, the TNC 620 is equally flexible when it comes to programming and machining.

### Positioning with Manual Data Input

You don't need to create a complete program in order to start machining with the TNC 620. You can machine a workpiece step by step using both manual machining and automatic positioning in any sequence.

### Programming at the machine

HEIDENHAIN controls are designed for shop-friendly programming right at the machine. Instead of requiring you to know G-codes, the Klartext conversational programming language provides its own buttons and soft keys for programming straight lines, arcs, and cycles. At the push of a button, HEIDENHAIN Klartext dialog guidance opens and actively helps you during programming on the TNC. Its clear instructions prompt you to enter all of the required data.

All interface texts, including Klartext tips, dialog prompting, program steps, and soft keys, are available in numerous languages.

And even if you prefer **ISO programming**, the TNC is still the right control: you can enter ISO command letters via soft keys or directly on the alphanumeric keyboard.

### Creating programs offline

The TNC 620 is also well equipped to handle offline programming. Through its interfaces it can be integrated into networks and connected with programming stations or other data storage devices.

### Programming graphics

The two-dimensional programming graphics give you additional assurance: while you are programming, the TNC 620 renders every programmed movement on the screen. You can opt for a plan view, side view, or front view. Tool paths or rapid-traverse movements can be hidden, and the image's scale can be changed.

### Program verification graphics (option 20)

For added certainty prior to machining, the TNC 620 can simulate and render the machining of the workpiece at high resolution. The TNC 620 provides various view formats of the simulation:

- Plan view at different levels of depth
- Three projections
- 3D view

The type and quality of the image can be selected, and details can be displayed at magnification. The TNC 620 also displays the calculated machining time in hours, minutes, and seconds. You can use STL files to integrate workpiece blanks and finished parts in the program.

The 3D view lets you display the programmed tool-center path in three dimensions, and a powerful zoom function lets you see even the tiniest details. The 3D line graphics are especially helpful in verifying programs created offline, allowing you to avoid undesired machining marks on the workpiece, such as those that occur when the postprocessor outputs points incorrectly. The 3D view of the TNC also provides a measuring function. When you move the mouse pointer anywhere within the image, the coordinates of that position are displayed. The measurement window also displays tool information.

During the machining simulation, the TNC 620 can also display all of the machine components defined by the machine manufacturer, in addition to the workpiece and tool. This rendering capability is particularly useful in Test Run mode, informing you ahead of time which positions are too close to components and when the traversing path will be insufficient. This is a huge benefit during machining with tilting axes.

### Program-run graphics (option 20)

The program-run graphics display the workpiece in real time in order to show you the machining progress. Direct observation of the workpiece is usually impossible due to coolant and the safety enclosure. During machining, you can switch between various operating modes at any time in order to create programs, for example. And at the press of a button, you can cast a glance at the machining progress while programming.

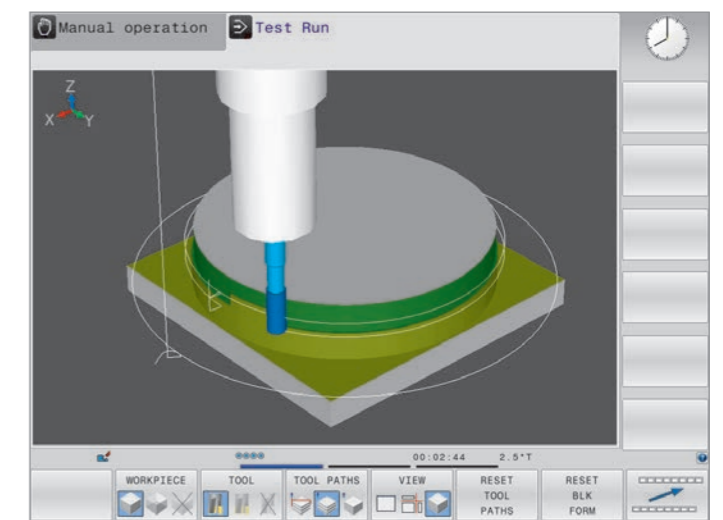
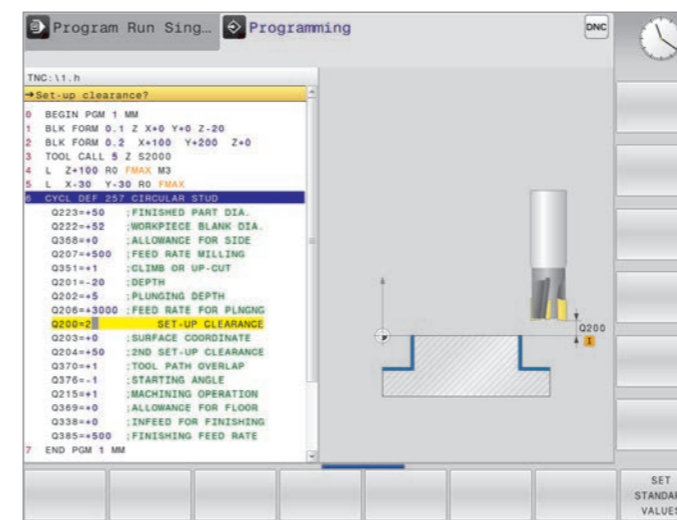
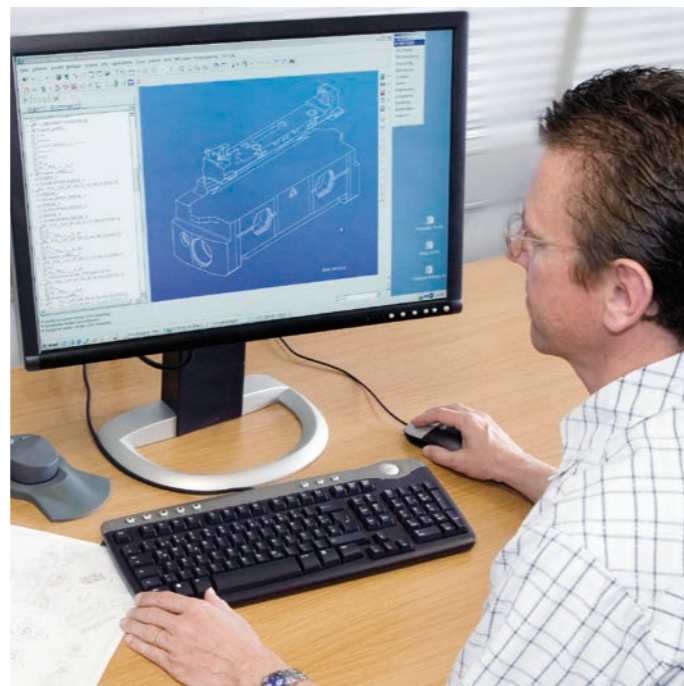



# Programming in the shop

## Straightforward function keys for complex contours

### Programming 2D contours

Two-dimensional contours are the bread and butter of a modern machine shop, which is why the TNC 620 offers a variety of ways to handle them.

### Programming with function keys

Are the contours properly dimensioned for NC machining? In other words, are the end points of the contour elements provided in either Cartesian or polar coordinates? If yes, then you can create the NC program straightaway using function keys.

### Straight lines and circular elements

To program a line segment, for example, simply press the linear traverse key. The Klartext conversational programming language of the TNC 620 then prompts you for all of the information needed by the programming block, including the target coordinates, feed rate, tool compensation value, and machine functions. Function keys for circular movements, chamfers, and corner rounding also simplify your programming work. In order to avoid surface blemishes during approach or departure from the contour, movement must be seamless—that is, tangential.

You simply specify the starting point or end point of the contour and the approach or departure radius of the tool. The control handles the rest.

The TNC 620 can foresee a contour with radius compensation by up to 99 blocks, thus taking back-cutting into account and avoiding contour gouging. This could be the case, for example, when roughing a contour with a large tool.

## Programming free contours and Data Matrix codes

### Fast and easy programming of a scannable Data Matrix code

Cycle 224 (Data Matrix code pattern) lets you convert any text into a Data Matrix code and machine it onto your workpiece as a point pattern using, say, drilling operations. The Data Matrix code can be decoded with common scanning devices. Serial numbers and production data can thus be permanently machined onto the part. All you need to do after defining a machining cycle is enter the text (up to 255 characters) into the cycle and specify the size and position of the drilling pattern. The control automatically calculates the Data Matrix code and performs the machining work on its own.

### FK free contour programming (option 19)

Not all workpieces are properly dimensioned in accordance with the ISO standard. Thanks to FK, the control's programming function for free contours, you can simply enter the known data without needing to convert or calculate anything! In such cases, individual contour elements can remain undefined as long as the overall contour itself is defined. If the data from the drawing yields more than one possible mathematical solution, then the helpful TNC 620 programming graphics show you the possible variants for your selection.

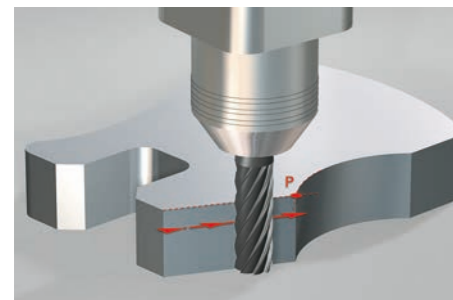
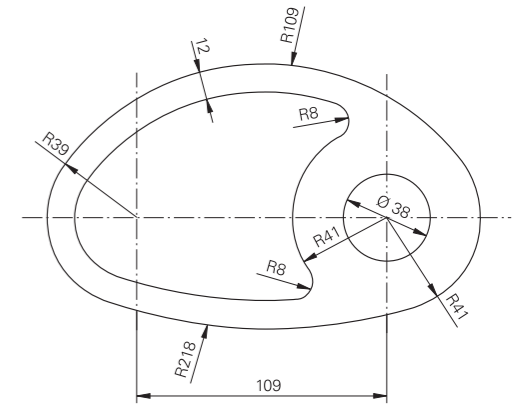

**L** Straight line defined by its end point

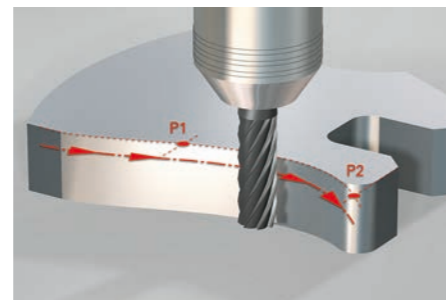

**CT** Circular path with smooth (tangential) connection with the preceding contour element, defined by end point

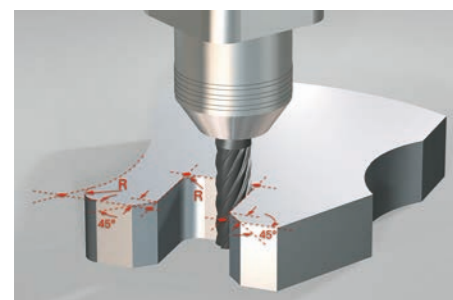

**RND** Corner rounding: circular path with a seamless (tangential) transition, defined by its radius and corner point

**CHF** Chamfer defined by the corner point and chamfer length

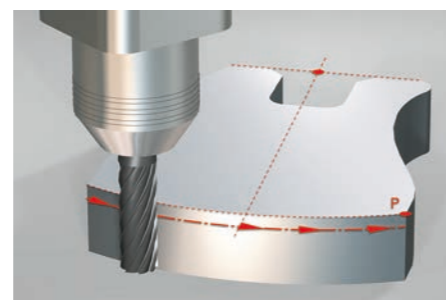

**CC + C** Circular path defined by its center, end point, and rotational direction

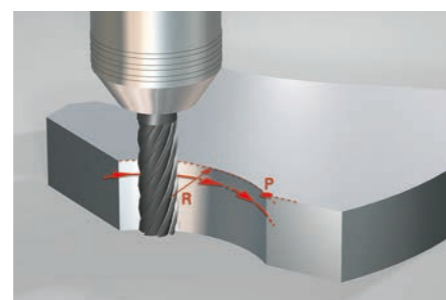

**CR** Circular path defined by its radius, end point, and rotational direction

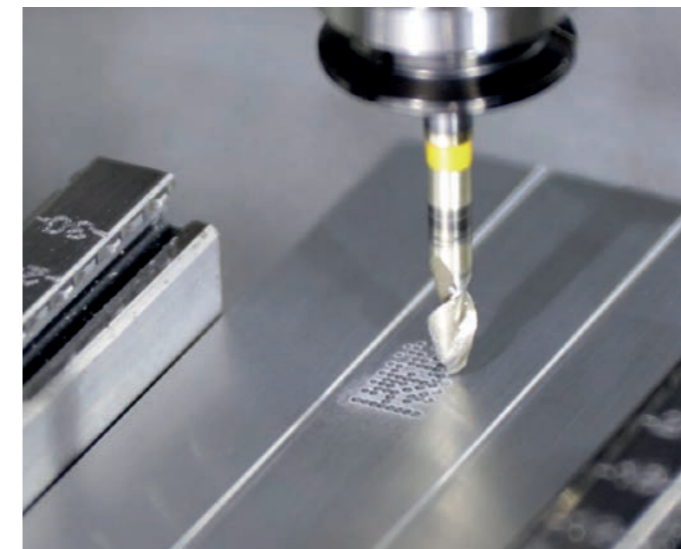

# Programming in the shop

## Practical cycles for recurring operations

### Extensive machining cycles for milling and drilling

Frequently recurring operations consisting of multiple machining steps are stored as cycles in the TNC 620. Dialog guidance and help graphics illustrating the required input parameters support you in programming them.

#### Standard cycles

In addition to drilling and tapping cycles (with or without a floating tap holder), a variety of selectable cycles are available:

- Thread milling
- Reaming
- Engraving
- Boring
- Hole patterns
- Milling cycles for face milling a flat surface
- Roughing and finishing of pockets, slots, and studs

### Cycles for complex contours (option 19)

Of great help in roughing pockets with any contour are the control's **SL cycles** (SL = Subcontour List) and **OCM** (Optimized Contour Milling, option 167). These functions refer to machining cycles for pilot drilling, roughing, and finishing in which the contour or subcontours are defined in subprograms. Thus, a single contour description can be used for more than one operation with different tools.

Up to twelve **subcontours** can be superimposed for the machining operation. The control automatically calculates the resulting contour and the tool paths for roughing or clearing the surfaces. Subcontours can be pockets or islands. Multiple pockets are combined to form a single pocket, with the tool bypassing any islands.

During roughing, a **finishing allowance** on the wall and floor surfaces is also taken into account by the TNC 620. When **roughing** with different tools, the control identifies residual material to be removed by smaller tools. A separate cycle is used for finishing to the final dimensions.

### OEM cycles (option 19)

Machine manufacturers can incorporate their specialized production expertise in the form of additional machining cycles and store them in the TNC 620. The end user can write his own cycles as well. HEIDENHAIN makes this possible with its PC software CycleDesign, which allows you to create input parameters and arrange the TNC 620's soft key structure as desired.

### Programming machining patterns with ease and flexibility

Positions to be machined are often arranged in patterns on the workpiece. The TNC 620's graphical support helps you program a wide range of machining patterns with ease and exceptional flexibility. You can define as many point patterns as desired with various numbers of points. During machining, you can then have all of the points executed as a unit, or each point individually.

### 3D machining with parametric programming

Simple, mathematically easy-to-describe 3D geometries can be programmed by means of parametric programming. At your disposal are basic arithmetical operations, trigonometric functions, roots, powers, logarithmic functions, parentheses, and logical comparisons with conditional jump instructions. Parametric programming also gives you a simple way to implement 3D operations. Of course, parametric programming is also well-suited for **2D contours** that cannot be described with lines or circular arcs but rather through mathematical functions.

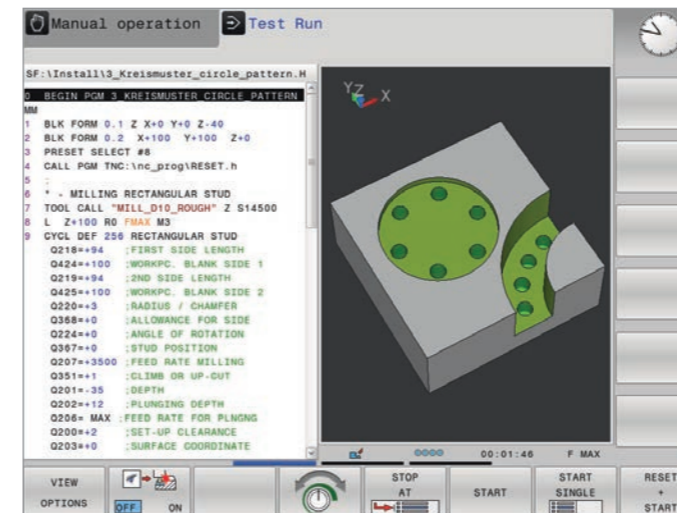
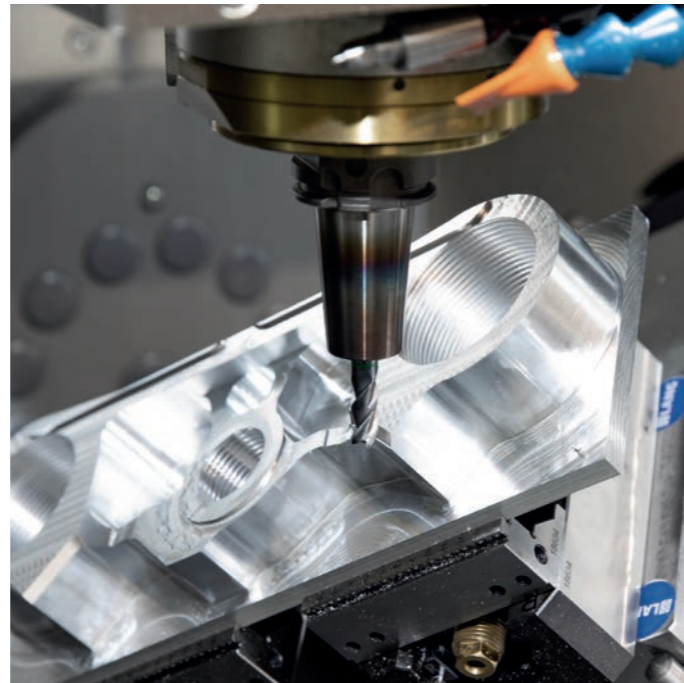



# Programming in the shop

## Reusing programmed contour elements

### Coordinate transformation

If you need a pre-programmed contour at different locations and in different sizes on the workpiece, then the TNC 620 offers you a convenient solution in the form of coordinate transformations.

With coordinate transformation you can, for example, rotate or mirror the coordinate system, or shift the datum. With a scaling factor you can enlarge or reduce contours to respect shrinkage or oversizes.

### Program-section repeats and subprograms

Many machining operations repeat themselves either on the same workpiece or on different workpieces. Once you have programmed a detail, there is no need to program it again. With its subprogram technology, the TNC can save you a great deal of programming time.

In **program-section repeats**, you can label a section of the program, and the TNC will repeat this section as many times as required.

You can mark a program section as a **subprogram** and then call it at any point in the program and as often as you want.

With the **program call** function, you can even use a completely separate program at any location in your current program. This allows you to leverage already programmed and frequently required working steps or contours.

Of course, you can also combine these programming techniques as often as desired.

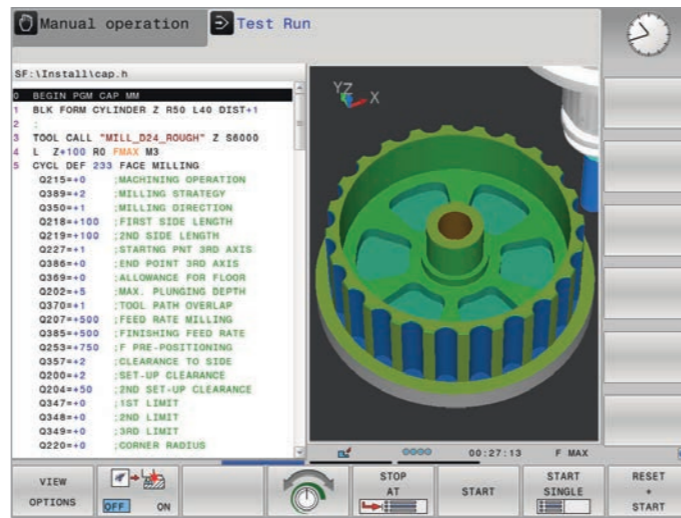

## Rapid availability of all information

Do you have questions about a programming step but your User's Manual is not at hand? No problem: both the TNC 620 control and the TNC 620 programming station feature TNCguide, a convenient help system that displays the user documentation in a separate window.

You can activate TNCguide simply by pressing the HELP key on the TNC keyboard or by clicking any soft key when the mouse pointer has switched to a question mark. This is easily done by clicking the help icon permanently displayed on the TNC screen.

TNCguide generally displays the information instantaneously and in the correct context (context-sensitive help), immediately giving you the information you currently need. This function is particularly helpful for soft keys and provides a detailed explanation of their effects.

You can download the documentation in the desired language free of charge from the HEIDENHAIN website and save it to the appropriate language directory of the TNC hard disk.

The following User's Manuals are available in the help system:

- Klartext Conversational Programming
- Setup, Testing, and Running NC Programs
- Programming of Machining Cycles
- Programming of Measuring Cycles for Workpieces and Tools
- ISO Programming
- TNC 620 Programming Station (installed only with the programming station)

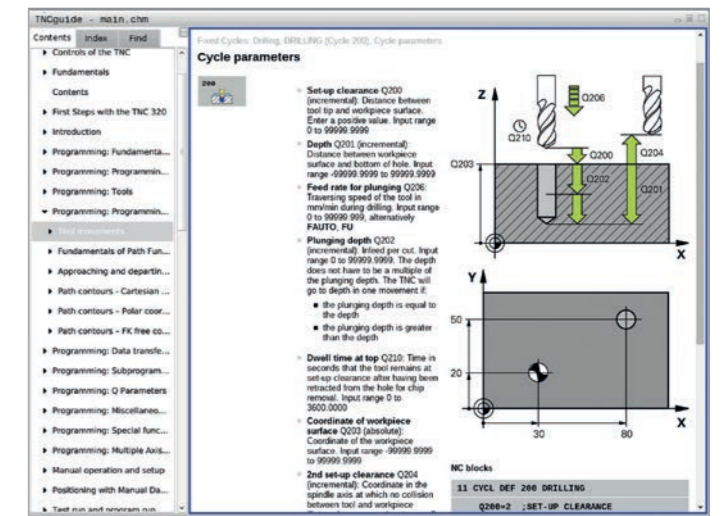
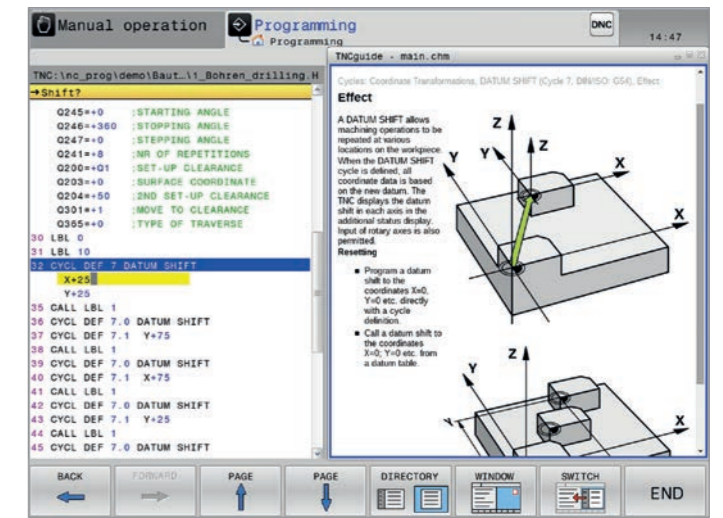

The TNC 620 is designed for exceptional accuracy and surface quality at high machining speeds, regardless of whether you are milling or turning. A variety of technologies, cycles, and functions operating separately or in concert ensure perfect surface finishes in extremely short machining times:

- Optimized motion control
- Effective jerk reduction
- Dynamic contour look-ahead

The umbrella term **Dynamic Precision** covers a number of HEIDENHAIN cutting solutions that can dramatically improve the dynamic accuracy of a machine tool. These solutions shed new light on the competing demands of accuracy, high surface quality, and short machining times. The dynamic accuracy of machine tools manifests itself in deviations at the tool center point (TCP). These deviations depend on kinetic quantities such as speed and acceleration (including jerk) arising from the vibration of machine components and other factors.

All of these factors contribute to dimensional inaccuracy and the formation of defects on the workpiece surface, thereby impacting both quality and productivity (in the case of quality-related scrap). Dynamic Precision counteracts these problems with intelligent control technology to help improve the quality and dynamic performance of a machine tool. As a result, production time and cost are reduced.

**Dynamic Precision** contains the following functions, which can be deployed separately or in combination.

Function		Benefits
<b>CTC</b> Cross Talk Compensation	Compensation of acceleration-dependent position errors at the TCP	Greater accuracy during acceleration phases
<b>MVC</b> Machine Vibration Control	Damping of machine oscillations  <b>AVD</b> (Active Vibration Damping): Compensates undesired effects of vibrations on the feed axes <b>FSC</b> (Frequency Shaping Control): Suppresses the inducement of vibrations through a correspondingly filtered feedforward control	A superior surface finish
<b>CTC + MVC</b>	–	Faster and more accurate machining
<b>PAC</b> Position Adaptive Control	Position-dependent adaptation of control parameters	Greater contour fidelity
<b>LAC</b> Load Adaptive Control	Load-dependent adaption of control parameters and the maximum axis acceleration	Higher accuracy whatever the load
<b>MAC</b> Motion Adaptive Control	Motion-dependent adaptation of control parameters	Less vibration and higher maximum acceleration during rapid traverse

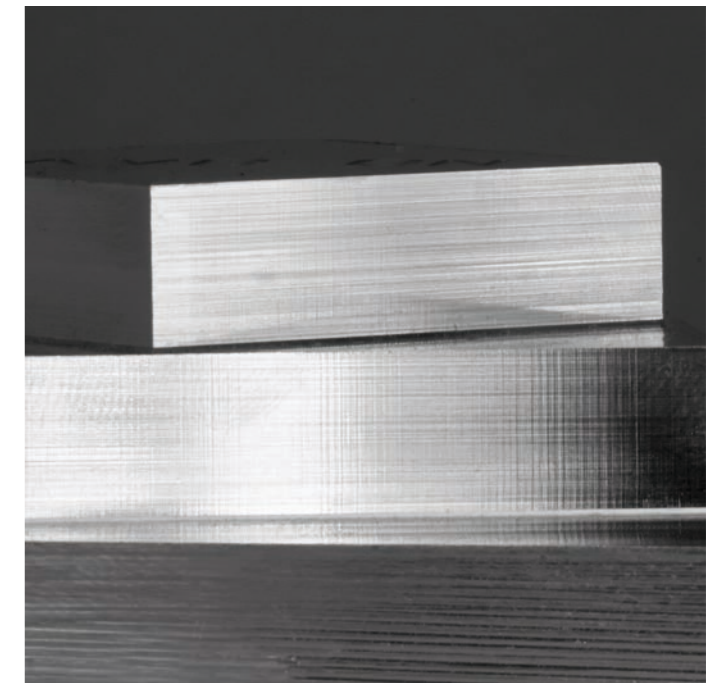
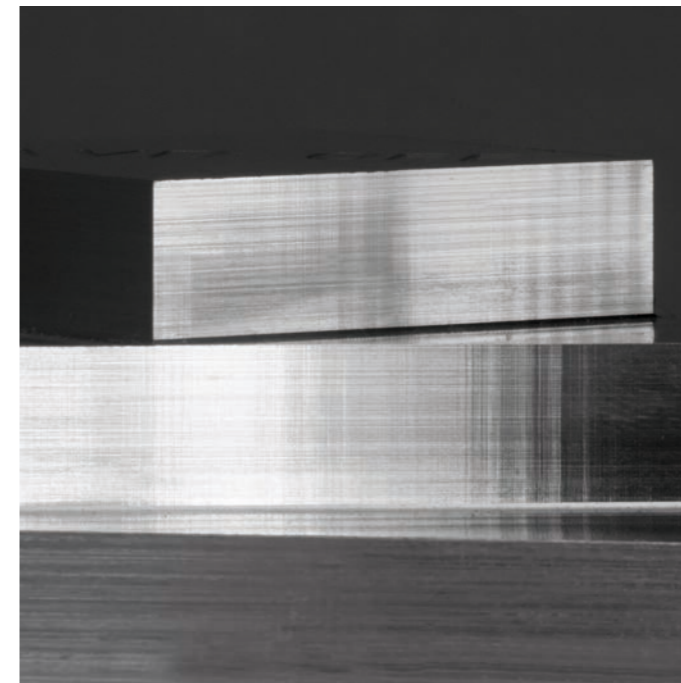

Vibration can significantly impair surface quality.

Visibly superior surface quality can be attained with MVC.



## Intelligent machining

### Machine any contour slot with trochoidal milling

The benefit of trochoidal milling is its ultra-efficient machining of slots of all kinds. In this cycle, roughing is performed with circular movements, onto which a forward linear movement is superimposed. This procedure is referred to as trochoidal milling. It is used particularly for milling high-strength or hardened materials, where the high loads placed on the tool and machine usually only permit small infeeds.

Thanks to the special cutting motion used in trochoidal milling, however, there are no added wear-inducing influences on the tool, and higher infeeds are possible. During hobbing, the entire cutting edge can be used as well. You thereby attain a higher material removal rate per tooth. Circular-motion plunging into the material exerts less radial force on the tool. This reduces the mechanical load on the machine and prevents vibration.

The slot to be machined is described in a contour subprogram as a contour train. You define the dimensions of the slot and the cutting data in a separate cycle. Any residual material can then be easily removed with a subsequent finishing cut.

The main benefits are as follows:

- Contact over entire cutter length
- Higher removal rates
- Less strain on the machine
- Less vibration
- Integrated finishing of the side wall
- Superior chip removal

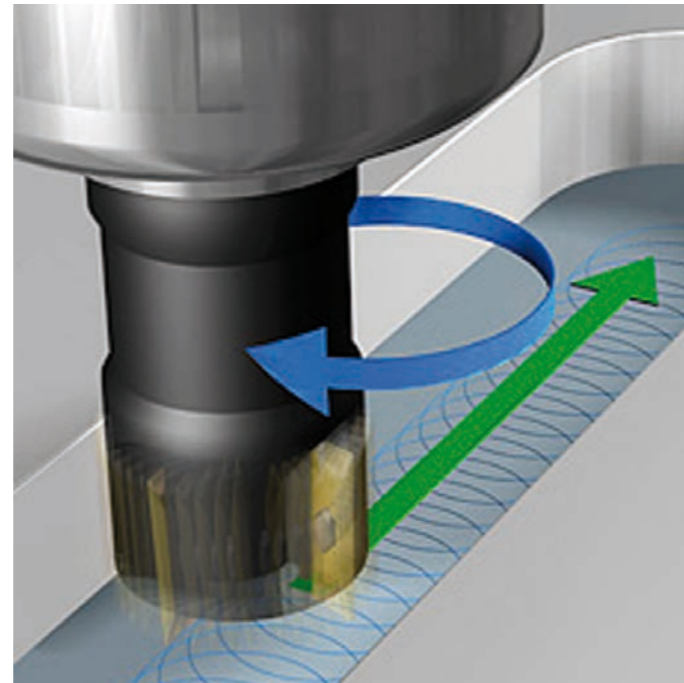

### Active Chatter Control option (ACC)

Roughing operations (power milling) give rise to strong milling forces. Depending on the rotational speed of the tool, the resonances in the machine tool, and the material removal rate during milling, the tool may begin to "chatter." Chatter puts the machine under heavy strain and causes blemishes on the workpiece surface. Tool wear is also accelerated and less evenly distributed. In extreme cases, the tool may even break.

To reduce chatter susceptibility, HEIDENHAIN now offers a highly effective optional control function called Active Chatter Control (ACC). This option is particularly beneficial during heavy machining:

- Improved cutting performance
- Higher removal rates (up to 25% and more)
- Lower forces on the tool, with increased tool life
- Less strain on the machine



Heavy machining without ACC (upper image) and with ACC (lower image)



# Intelligent machining

Optimized roughing processes with OCM (option)

Efficient machining strategies are a key basis for economical NC manufacturing. Roughing processes, in particular, offer great potential for optimization because they usually make up a sizeable portion of the total machining time.

With OCM, you can rough out any pocket and island with high process reliability and lower tool wear thanks to highly consistent process conditions. You simply program the contour as usual directly in Klartext or make use of the convenient CAD Import function. The control then automatically calculates the complex movements required for maintaining consistent process conditions.

Process reliability and maximum removal rates require optimal adaptation of the cutting data to the characteristics of the tool and part material. OCM gives you a cutting data calculator that draws on a comprehensive integral materials database. You can then adapt the automatically calculated cutting values by taking the specific mechanical and thermal load on the tool into account. Tool service life can be managed with process reliability even at the highest possible removal rates.

### Advantages of OCM over conventional machining:

- Reduced thermal load on the tool
- Superior chip removal
- Uniform cutting conditions

### OCM is an effective, reliable, and convenient way to improve your throughput

- Create programs on the shop floor for any pocket or island
- Significantly higher machining speed
- Considerable reduction in tool wear
- More chips in less time

The OCM option provides practical cycles for roughing, side-wall finishing, and floor finishing.

OCM also permits chamfering and deburring of contours. With this capability, only those areas that can be machined without collisions due to the tool geometry are machined.

Conventional machining
<i>S5000, F1200, a<sub>p</sub>: 5.5 mm</i>
<i>Overlap factor: 5 mm</i>
<i>Machining time: 21 min 35 s</i>

*Tool: VHM end mill (Ø 10 mm)*  
*Workpiece material: 1.4104*

Machining with OCM
<i>S8000, F4800, a<sub>p</sub>: 22 mm</i>
<i>Overlap factor: 1.4 mm</i>
<i>Machining time: 6 min 59 s</i>

*Tool: VHM end mill (Ø 10 mm)*  
*Workpiece material: 1.4104*



## dynamic + efficiency

In order to machine standard shapes, OCM offers various figures that are then used as a pocket, island, or boundary for face milling in conjunction with other OCM cycles.

In the machining example illustrated here, both the machining time and tool wear were reduced **by a factor of three**.

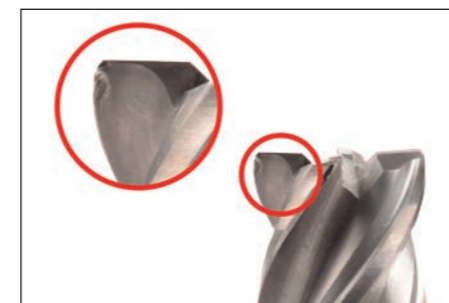

Tool after two parts

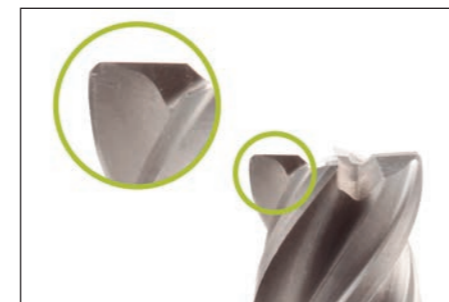

Tool after six parts

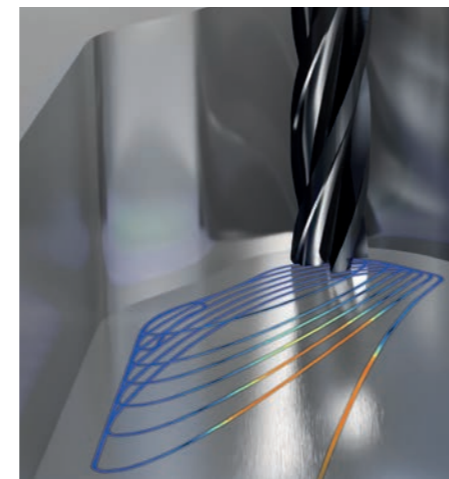

# Open to outside information

StateMonitor: collect and evaluate machine data

StateMonitor collects and visualizes the statuses of production machines. By evaluating important data such as the current machine status, machine messages, override positions, and utilization history, StateMonitor provides in-depth information about the machine's degree of utilization. Based on the data it collects, StateMonitor also reveals machine-specific optimization potential. By entering comments regarding machine downtimes and setup times, the operator can also uncover potential for improvement at the organizational level. Via the Messenger function, StateMonitor notifies the right person by e-mail based on individually combinable machine signals and statuses.

StateMonitor collects and visualizes the following information from the networked machines:

- Operating modes
- Override positions (spindle, rapid traverse, feed rate)
- Program status and program name, as well as subprograms if applicable
- Program run time
- SIK number and software number
- Machine messages

Active support for production planning with an extensive range of functions for job data collection:

- Create and assign jobs
- Start and terminate jobs
- Plan setup times and interruptions
- Store additional job data, such as quantities produced

StateMonitor even lets you connect machines with different controls and supports the following protocol types: HEIDENHAIN DNC, OPC UA, MTConnect, and ModbusTCP.

For more information, please contact HEIDENHAIN.

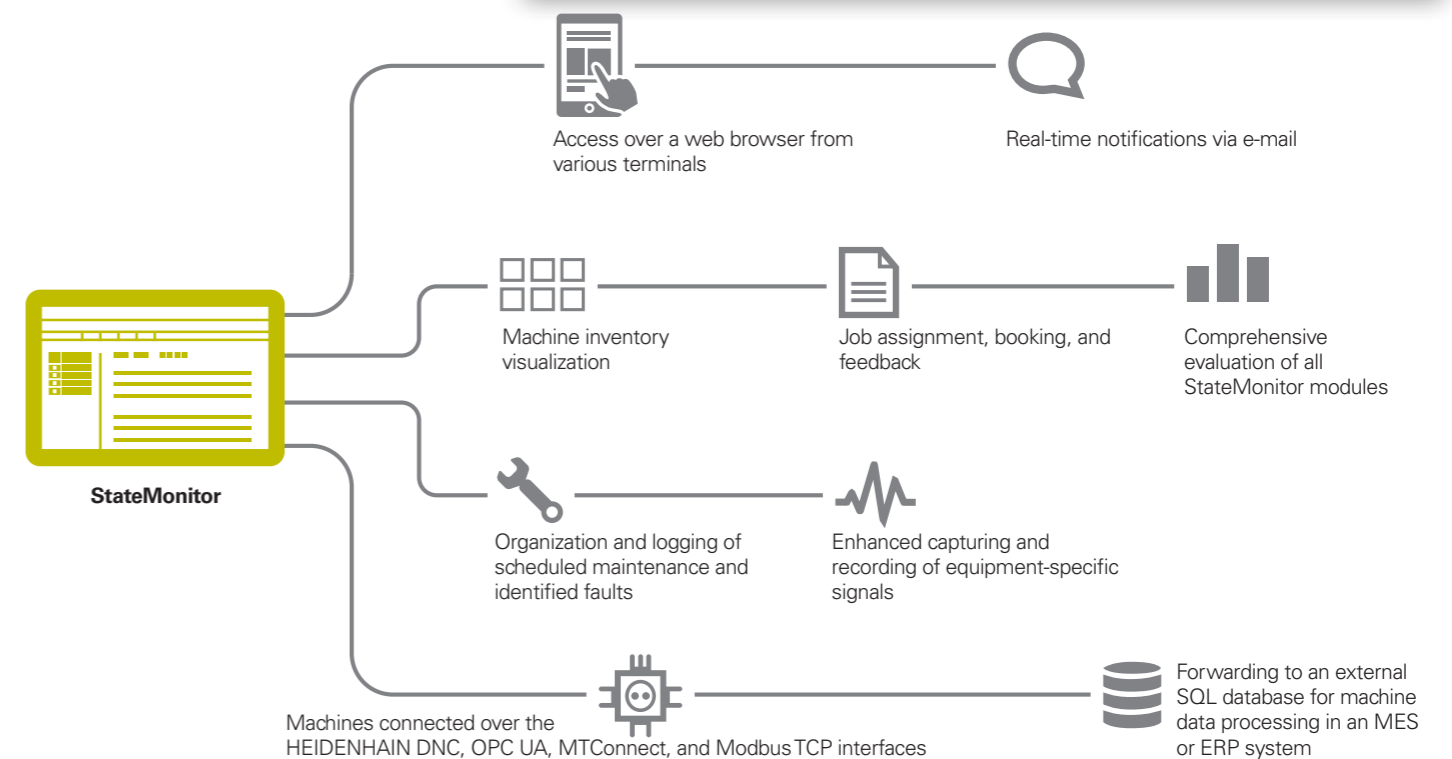
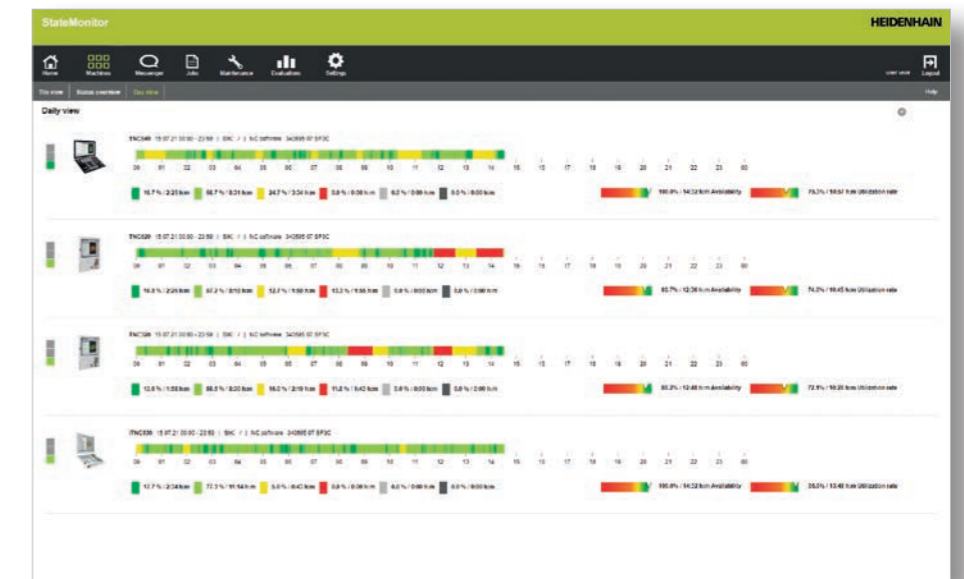



# Open to outside information

## Uniformly digital job management with Connected Machining



The smooth exchange of knowledge is crucial for the success of a company. In order for knowledge to be transferred rapidly and without loss, e-mail communication capability is just as important as the continuous availability of electronic production documents or the transfer of data to ERP and production-activity control systems. Tool and raw material inventories, tool data, workholding drawings, CAD data, NC programs, and inspection instructions must all be available to machine operators on all shifts. Cost-effective manufacturing therefore requires an efficient process chain and a networked control.

The TNC 620, with its **Connected Machining** package of functions, integrates itself flexibly into your process chain and helps you to optimize the transfer of knowledge within your company. So let your workshop, as well,

benefit from all of the information available within your company. **Connected Machining** makes uniformly digital job management possible within a networked manufacturing environment. You thereby benefit from the following:

- Ease of data usage
- Time-saving procedures
- Transparent processes

### The networked TNC 620

Integrate the TNC 620 with the functions of **Connected Machining** into your corporate network and, via the control, connect the shop floor to PCs, programming stations, and other data storage media in these areas of the company:

- Design
- Programming
- Simulation
- Production planning
- Production

Even the basic version of the TNC 620 is equipped with two Gigabit Ethernet ports of the latest generation. The TNC 620 uses the TCP/IP protocol to communicate with NFS servers and Windows networks without requiring additional software. The fast data transfer at rates of up to 1000 Mbit/s ensures very short transmission times. The TNC 620 therefore offers the optimal technological platform for **Connected Machining**, the networking of the control in the shop with all production-related areas of your company.

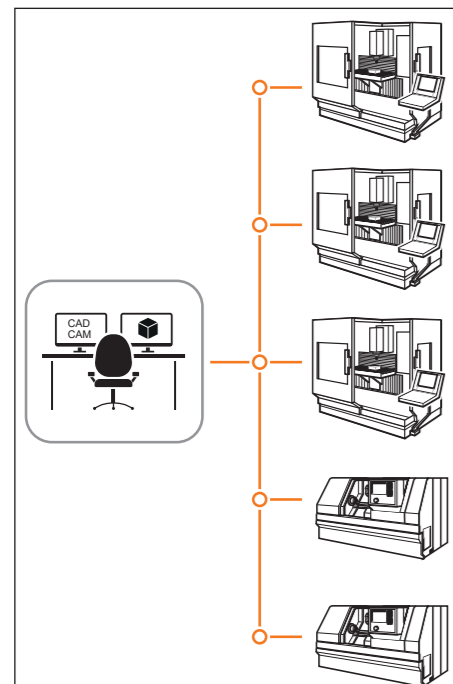

### Standard range of functions

For you to be able to use the data that you transfer to the TNC 620 over a network, the TNC 620 offers attractive applications, even as part of its standard range of functions. The CAD viewer, PDF viewer or Mozilla Firefox web browser enable the simplest form of **Connected Machining**: access to manufacturing process data right at the control. In this case, operating web-based documentation systems or ERP systems is just as feasible as accessing your e-mail inbox. The following file formats can also be opened directly on the TNC 620:

- Text files
- Graphic files ending in .gif, .bmp, .jpg, .png
- Table files ending in .xls or .csv
- HTML files

### Data transfer

An enhanced solution for fully digital job management within the context of **Connected Machining** is the free-of-charge **TNCremo** PC software. With it, you can transfer remotely stored part programs and pallet tables in both directions over the Ethernet.

With the powerful **TNCremoPlus** PC software, you can also transfer the screen contents from the control to your PC using the live-screen function.

### Provision of operating states

Option 137, State Reporting Interface (SRI), gives you a simple and reliable interface for recording the operating data of your machine. It records the idle times, run times, and fault messages of your machine. SRI also provides historical operating data that can still be retrieved even after the corporate network has been down for hours at a time.

### Job-related data

With **REMOTE DESKTOP MANAGER (option 133)**, you can operate a Windows PC from the TNC 620. On the control, you gain direct access to EDP systems within the process chain and make your machine setup processes significantly more efficient by reducing inconvenient legwork between the machine and the office. Technical drawings, CAD data, NC programs, tool data, work instructions, parts lists, and warehouse information are digitally available at the machine. E-mails can be sent and received with ease. With a simple keystroke on the machine operating panel, you can switch between the control screen and the screen of the Windows PC. This PC can be a computer in the local network or an industrial PC (IPC) in the machine's electrical cabinet.

### HEIDENHAIN OPC UA NC Server

With OPC UA NC Server, HEIDENHAIN offers a reliable interface for the integration of modern industrial applications. The standardized protocol and the application-oriented information model enable seamless and economical integration of the TNC control into your production environment.

- **State-of-the-art IT security:** Authentication, authorization, and cryptography
- **Uncomplicated:** Guided connection configuration
- **Application-oriented:** Tailored to the demands of modern industrial applications
- **Standardized:** OPC UA is the communication technology recommended for Industry 4.0
- **Freedom of choice:** Open selection of operating system and toolkit
- **Virtual testing environment:** Free HEIDENHAIN programming station



### Component monitoring

During their lifecycle, load-sustaining machine components such as guideways and ball screws exhibit wear, thus causing the quality of axis motion to diminish. This, in turn, affects production quality. With Component Monitoring (option 155) and a cycle, the control is able to measure the current condition of the machine. As a result, any deviations from the machine's shipping condition due to wear and aging can be measured. The machine manufacturer can read and evaluate the data, and react using predictive maintenance, thereby avoiding unplanned machine downtimes.

### Detailed data for the optimal organization of production processes

HEIDENHAIN DNC enables, among other things, the connection of TNC controls to inventory management systems and production-activity control systems. Automatic feedback messages about active production processes, for example, can be set up over this interface.



# Open to outside information

## Processing CAD files with the TNC 620

### CAD viewer

With the standardly available CAD viewer software, you can open 3D CAD models and drawings directly on the TNC 620. Various view options as well as rotation and zoom capabilities allow for a detailed visual inspection and analysis of your CAD data. You can also use the viewer to ascertain position values from a 3D model. You simply select an arbitrary reference point in your drawing and select the desired contour elements. The CAD viewer then displays the coordinates of the elements in a window. The CAD viewer can depict the following file formats:

- STEP files (.STP and .STEP)
- IGES files (.IGS and .IGES)
- DXF files (.DXF)

### CAD Import (option 42)

Why program complex contours if you already have the drawing as a DXF, STEP, or IGES file? After all, you have the ability to extract contours or machining positions from these types of CAD files. This not only saves time otherwise spent on programming and testing, but you can also be sure that the finished contour is exactly in accordance with the design engineer's specifications.

Extracting machining information directly from CAD data offers additional possibilities, particularly for the creation of NC programs with a tilted machining plane. You can also define the preset with a 3D basic rotation of the 3D model and set a datum with the appropriate 3D rotation in the desired working plane.

You can easily save the working plane to the clipboard and transfer it to the NC program with the appropriate transformation and the associated PLANE command. In the defined working plane, you can extract contours and machining positions, and apply them to the NC program.

Selecting contours is very convenient: you can select any element by clicking it with the mouse. Once you select a second element, the TNC detects your desired machining direction and initiates automatic contour detection. In doing so, the TNC automatically selects all clearly identifiable contour elements until the contour closes or branches out. This method lets you define elaborate contours with just a few clicks of the mouse. Then you can simply copy the selected contour to an existing Klartext program using the clipboard.

You can also select **machining positions** and save them as point files, especially in order to apply hole positions or starting points for pocket machining. This can be done very easily by selecting the desired area with the mouse. In a pop-up window with a filter function, the TNC displays all of the hole diameters within the area you have selected. To select the desired hole diameters and restrict the number of hole positions, simply click the corresponding filter symbol to change the filter limits. A zoom function and various configuration possibilities round out the functionality of CAD Import.

It is also possible to define the contour program's resolution for using it in older TNC controls. You can also define a transition tolerance if the contour elements are not completely connected.

The following positions can be defined as presets:

- The beginning, end, or mid-point of a line
- The beginning, end, or center point of a circular arc
- Quadrant transitions or center point of a circle
- Intersection of two lines, even only in their extension
- Intersection of a line and a circular arc
- Intersection of a line and a circle

If multiple intersections between two elements are possible (e.g., between a straight line and a circle), then you can select the correct intersection with a mouse click.

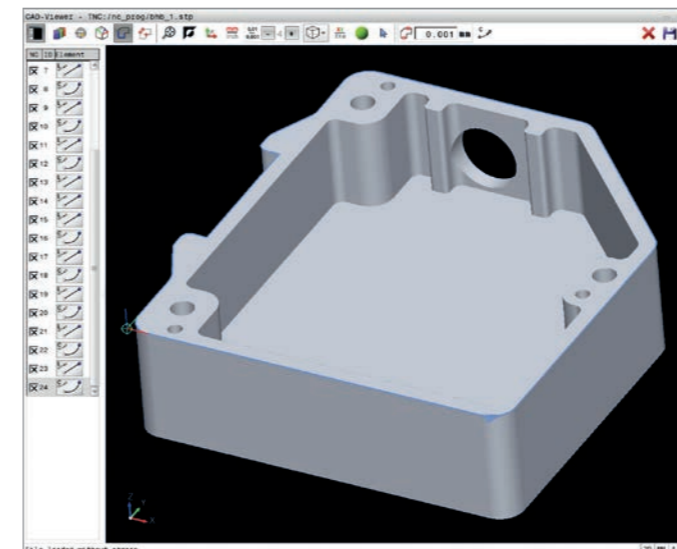

Part program on the basis of the imported DXF file

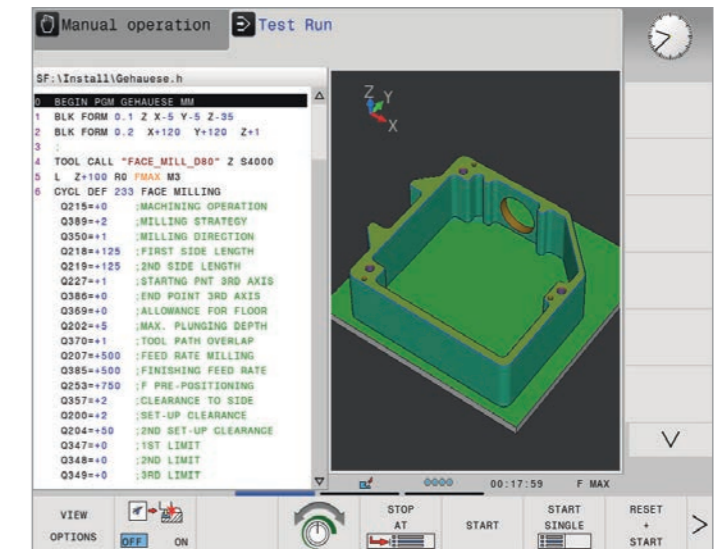

Display of a 3D model in the CAD viewer



## Open to outside information

### The TNC 620 programming station

#### What's the purpose of a programming station?

As easy as it is to write a part program on a TNC 620 at the machine while a different part is being machined, short reloading times or high machine utilization may hinder attentive programming work on the shop floor. The TNC 620 programming station lets you program the same way you would at the machine but away from all the noise and distractions.

#### Creating programs

The programming, testing, and optimizing of HEIDENHAIN Klartext or ISO programs with the programming station substantially reduces machine idle times. And it's easy to get used to because every keystroke feels the same: the programming station's keyboard is just like the one on the machine.

#### Testing programs created offline

Naturally, you can also test programs that were written on a CAD/CAM system. The various views of the program verification graphics help you easily spot contour damage and hidden details.

#### Training with the programming station

Since the TNC 620 programming station is based on the same software as the TNC 620 control, it is ideal for apprentice and advanced-level training. Programming is performed on the original keyboard unit, and even the test run feature runs exactly as it would on the machine. This gives the trainee the experience needed to safely work on the real machine.

The TNC 620 programming station is also optimally suited for teaching TNC programming skills in schools, since the TNC 620 can be programmed in Klartext and with ISO codes.

#### Your workstation

The programming station software runs on a PC. The PC screen shows you the same TNC user interface as the control and offers the familiar graphical support. Depending on the version of the programming station, there are multiple ways of using it.

The free **demo version** contains all of the TNC 620's functions and allows short programs to be saved. Programming is performed on the PC keyboard.

The version with a **TNC operating panel** lets you create programs in the accustomed manner on a keyboard featuring the same function keys as the control on the machine. It also has a PC keyboard for ISO programming, file names, and comments.

You can also work without the TNC operating panel: a **virtual keyboard** for operating the programming station is shown on the PC screen. This virtual keyboard provides the TNC 620's most important dialog-opening keys.

#### Further information:

Comprehensive descriptions of the programming station and a free demo version are available on the Internet at [www.heidenhain.com/programming-stations](http://www.heidenhain.com/programming-stations).



## Positioning with an electronic handwheel

### Fine motion control of axes

You can set up the workpiece by manually jogging the axes with the axis direction keys, but this task is easier and more finely controllable with the electronic handwheels from HEIDENHAIN.

In this method, the axis slides are moved by the feed motor in accordance with the handwheel's rotation. For particularly high sensitivity, you can incrementally set the amount of traversing distance for each handwheel rotation.

#### Panel-mounted handwheel

The HR 130 panel-mounted handwheel from HEIDENHAIN can be integrated into the machine operating panel or mounted to a different part of the machine.

#### Portable handwheels

The HR 510, HR 520, and HR 550 portable handwheels are particularly helpful when you work near the machine's working space. The axis keys and certain function keys are built into the housing. In this way, you can switch axes and set up the machine at any time—regardless of where you happen to be standing. As a wireless handwheel, the HR 550 is ideal for use on large machines. If you no longer need the handwheel, simply attach it to the machine using its built-in magnets.

#### Expanded range of functions of the HR 520 and HR 550

- Definable traversing distance per revolution
- Display for operating mode, actual position value, programmed feed rate, handwheel offset, spindle speed, and error messages
- Override potentiometers for feed rate, handwheel offset, and spindle speed
- Selection of axes by means of keys and soft keys
- Keys for continuous traverse of the axes
- Emergency stop button
- Actual position capture
- NC start/stop
- Spindle on/off
- Soft keys for machine functions defined by the machine manufacturer



HR 550

## Workpiece measurement

Setup, preset setting, and measuring with touch trigger probes

Workpiece touch probes\* from HEIDENHAIN help you keep costs down in the shop and in serial production: when used in conjunction with the TNC 620, they enable the automated execution of setup, measurement, and inspection functions.

Upon contact with the workpiece surface, the stylus of a TS touch trigger probe is deflected. In that instant, the TS generates a triggering signal that, depending on the model, is transmitted either by cable or an infrared beam to the control.

The touch probes are inserted directly into the machine tool spindle and can be equipped with various taper shanks depending on the machine. The ball tips, which are made of ruby, are available in different diameters with various stylus lengths.

\* The machine and TNC must be specially adapted by the machine manufacturer.



TS 460

### Cable-bound touch probes

For machines requiring manual tool changes, as well as for grinding machines and lathes:

#### TS 150/TS 750

- Axial or radial cable connection on its base
- High probing accuracy and repeatability
- Compact dimensions

#### TS 260

- Axial or radial cable connection
- High scanning accuracy

### Wireless touch probes

For machines with an automatic tool changer:

#### TS 460

- Standard touch probe for radio and infrared transmission
- Compact dimensions
- Energy-saving mode
- Optional collision protection
- Thermal decoupling

#### TS 642

- Activation via switch in taper shank
- Infrared transmission

#### TS 740

- High scanning accuracy
- High reproducibility
- Low probing forces
- Infrared transmission

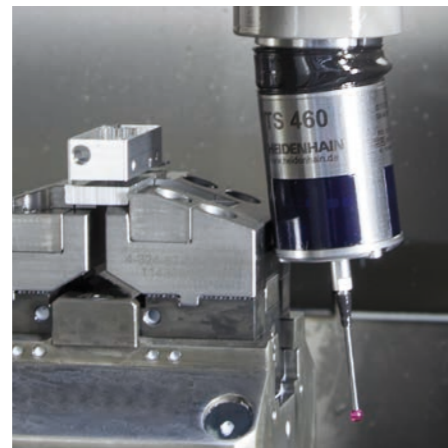

TS 460 with collision protection

### Transceiver unit

Radio or infrared transmission is established between the TS or TT touch probe and the SE transceiver:

#### SE 660

- For radio or infrared transmission (hybrid technology)
- Same SE for TS 460 and TT 460

#### SE 661

- For radio or infrared transmission (hybrid technology)
- Same SE for TS 460 and TT 460
- EnDat functionality for transmission of the switching state, diagnostics, and additional information



SE 660

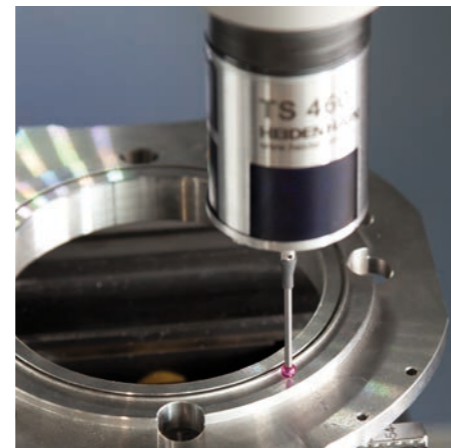

## Tool measurement

Measuring length, radius, and wear inside the machine

A key factor in obtaining consistently high production quality is, of course, the tool. This requires exact measurement of the tool dimensions and periodic inspection of the tool for breakage, wear, and tooth shape. For tool measurement, HEIDENHAIN offers the TT triggering tool touch probes.

These touch probes are installed directly within the machine's workspace, where they enable tool measurement either before machining or during interruptions.

The **TT tool touch probes** measure the tool length and radius. During probing of the rotating or stationary tool, such as for individual tooth measurement, the contact plate is deflected and a trigger signal is transmitted directly to the TNC 620.

The **TT 160** uses cable-bound signal transmission, whereas the **TT 460** sends its signals via radio or infrared transmission. It is thus particularly well suited for use on rotary/tilting tables.

To prevent limiting the machining space and avoid collisions, the TT touch probe must occasionally be removed from the machine. The touch probe's new magnetic base features three contact points and a setting screw. As a result, the touch probe requires calibration only during initial installation and can then be re-installed and removed with a quick hand movement.

Here are the benefits in a nutshell:

- Fast re-installation without recalibration
- Low-profile base
- Same accuracy as a permanent installation



TT 460



### Further information:

You can find detailed descriptions of workpiece touch probes on the Internet at [www.heidenhain.com](http://www.heidenhain.com) or in the *Touch Probes for Machine Tools* brochure.

### Further information:

You can find detailed descriptions of tool touch probes on the Internet at [www.heidenhain.com](http://www.heidenhain.com) or in the *Touch Probes for Machine Tools* brochure.



# Inspecting and optimizing machine accuracy

## Easy calibration of rotary axes with KinematicsOpt (option)

Accuracy demands are on the rise, particularly in the realm of 5-axis machining. Complex parts must be manufactured with both precision and reproducible accuracy, including over extended periods of time.

The TNC function **KinematicsOpt** is an important ingredient in helping you meet these high requirements: with a HEIDENHAIN touch probe inserted, a cycle measures your machine's rotary axes fully automatically. The measuring process is the same, regardless of whether the rotary axis is a rotary table, tilting table, or a swivel head.

For calibrating the rotary axes, a calibration sphere is mounted at any position on the machine table and probed with the HEIDENHAIN touch probe. Prior to this, you define the resolution of the measurement and the range that you want to measure for each rotary axis.

Based on the measured values, the TNC calculates the static tilting accuracy. The software minimizes the spatial error arising from the tilting movements and, at the end of the measuring process, automatically saves the machine geometry in the respective machine constants of the kinematics description.

Of course, a detailed log file is also available in which the measured and optimized dispersion (measure of the static tilting accuracy) is saved along with the actual measured values and the actual compensation values.

Optimal use of KinematicsOpt requires a highly rigid calibration sphere for reducing the deformations caused by probing forces. For this purpose, HEIDENHAIN offers calibration spheres with highly rigid holders of various lengths.

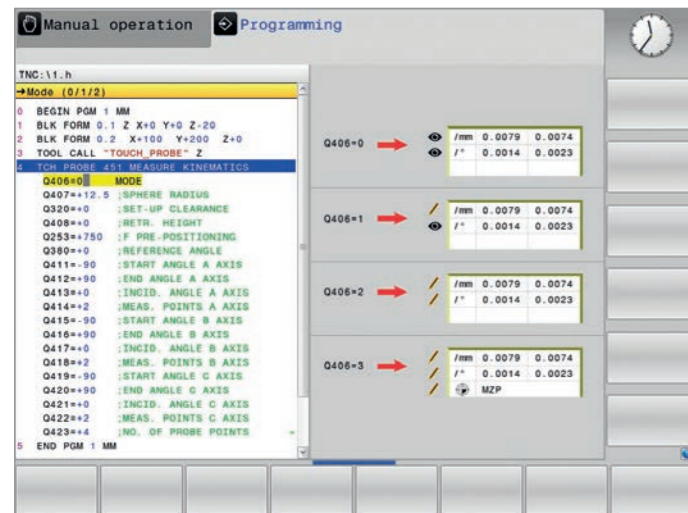

# Overview

## Specifications

Specifications	Standard	Option	
<b>Components</b>	✓		19-inch portrait screen (1024 x 1280 pixels) for multitouch operation 15-inch screen (1024 x 768 pixels) for multitouch operation
<b>Operating system</b>	✓		HEROS 5 real-time operating system for machine control
<b>Memory</b>	✓		30 GB CFR: 7.7 GB TNC partition 8 GB CFR: 2 GB TNC partition
<b>Input resolution and display step</b>	✓	✓	Linear axes: down to 0.01 µm Rotary axes: down to 0.00001°
<b>Input range</b>	✓		Maximum: 999 999 999 mm or 999 999 999°
<b>Interpolation</b>	✓	9 ✓ 8 ✓	Linear in 4 axes Linear in up to 5 axes (export license required) Circular in 2 axes Circular in 3 axes with tilted working plane Helical: superimposition of circular and straight paths
<b>Block processing time</b>	✓		1.5 ms (3D straight line without radius compensation)
<b>Axis feedback control</b>	✓ ✓		Position-loop resolution: signal period of the position encoder/4096 Position controller cycle time: 200 µs (100 µs with option 49)
<b>Spindle speed</b>	✓		Maximum: 100 000 rpm (with two pole pairs)
<b>Error compensation</b>	✓ ✓		Linear and nonlinear axis error, backlash, reversal peaks during circular movements, reversal error, thermal expansion Static friction, sliding friction
<b>Data interfaces</b>	✓ ✓ ✓ ✓	18 56- 61	One each: RS-232-CV.24 max. 115 kbit/s Extended data interface with LSV2 protocol for remote operation of the TNC over the data interface with the TNCremo or TNCremoPlus software from HEIDENHAIN Gigabit Ethernet interface 1000BASE-T USB: rear: 4 x USB 3.0; front: depends on the component HEIDENHAIN-DNC for communication between a Windows application and the TNC (DCOM interface) HEIDENHAIN OPC UA NC Server Reliable and stable interface for the connection of state-of-the-art industrial applications
<b>Diagnostics</b>	✓		Fast and simple troubleshooting through integrated diagnostic aids
<b>Ambient temperature</b>	✓ ✓		Operation: +5 °C to +40 °C Storage: -20 °C to +60 °C

# Overview

## User functions

User function	Standard	Option	
<b>Short description</b>	✓ ✓	0/1	Basic version: 3 axes plus closed-loop spindle 1st or 2nd additional axis for 4 or 5 axes plus spindle Digital current and speed control
<b>Program entry</b>	✓ ✓	42	HEIDENHAIN Klartext ISO ( <i>with integrated operating panel: via soft keys or external standard USB keyboard; with separate operating panel: via ASCII keyboard</i> ) Importing of contours or machining positions from CAD files (STP, IGS, DXF) and saving them as a Klartext contour program or Klartext point table
<b>Position entry</b>	✓ ✓ ✓		Nominal positions for straight lines and arcs in Cartesian coordinates or polar coordinates Incremental or absolute dimensions Display and entry in mm or inches
<b>Tool compensation</b>	✓	21 9	Tool radius in the working plane, and tool length Radius-compensated contour look-ahead for up to 99 blocks (M120) Three-dimensional tool-radius compensation for changing tool data without having to recalculate an existing program
<b>Tool tables</b>	✓		Multiple tool tables with any number of tools
<b>Cutting data</b>	✓	167	Automatic calculation of spindle speed, cutting speed, feed per tooth, and feed per revolution OCM: automatic calculation of overlap factor, milling feed rate, spindle speed, climb or up-cut milling, lateral infeed, cutting speed, material removal rate, recommended cooling
<b>Constant contour speed</b>	✓ ✓		Relative to the path of the tool center point Based on the tool's cutting edge
<b>Parallel operation</b>	✓		Program creation with graphical support while another program is running
<b>3D machining</b>	✓	9 9 9 9 9	Motion control with highly smoothed jerk 3D tool compensation via surface-normal vectors Changing the swivel-head angle with the electronic handwheel during program run without affecting the tool tip position (TCPM = Tool Center Point Management) Keeping the tool perpendicular to the contour Tool radius compensation perpendicular to the tool direction Manual traverse in the active tool-axis system
<b>Rotary table machining</b>		8 8	Programming cylindrical contours on an unrolled cylinder Feed rate in mm/min
<b>Contour elements</b>	✓ ✓ ✓ ✓ ✓ ✓		Straight line Chamfer Circular path Circle center Circle radius Tangentially connecting circular arc Corner rounding
<b>Contour approach and departure</b>	✓ ✓		Via straight line: tangential or perpendicular Via circular arc
<b>Free contour programming</b>	✓		FK free contour programming in HEIDENHAIN Klartext format with graphical support for workpiece drawings not dimensioned for NC

User function	Standard	Option	
<b>Program jumps</b>	✓ ✓ ✓		Subprograms Program-section repeat Any program as a subprogram
<b>Fixed cycles</b>	✓	19 19 19 19 19 19 19 19 19 19 19 19 167	Drilling, conventional and rigid tapping, rectangular and circular pockets Peck drilling, reaming, boring, counterboring, centering Milling internal and external threads Clearing level and oblique surfaces Complete machining of rectangular and circular pockets, rectangular and circular studs Complete machining of straight and circular slots Circular and linear point patterns Point pattern: Data Matrix code Contour train, contour pocket Contour slot with trochoidal milling Engraving cycle: engrave text or numbers in a straight line or on an arc OEM cycles (special cycles developed by the machine manufacturer) can be integrated Optimized Contour Milling (OCM) cycles: optimization of roughing processes
<b>Coordinate transformation</b>	✓	8	Shifting, rotating, mirroring, scaling (axis-specific) Tilting the working plane, PLANE function
<b>Q parameters</b> Programming with variables	✓ ✓ ✓ ✓ ✓ ✓		Mathematical functions =, +, -, *, /, sin α, cos α, tan α, arc sin, arc cos, arc tan, a <sup>n</sup> , e <sup>n</sup> , ln, log, √a, √a <sup>2</sup> + b <sup>2</sup> Logical operations (=, = /, <, >) Calculating with parentheses Absolute value of a number, constant π, negation, truncation of digits before or after the decimal point Functions for calculation of circles Functions for text processing
<b>Programming aids</b>	✓ ✓ ✓ ✓ ✓ ✓		Calculator Complete list of all current error messages Context-sensitive help function for error messages TNCguide: the integrated help system; user information available directly on the TNC 620 Graphical support for the programming of cycles Comment and structure blocks in the NC program
<b>Teach-in</b>	✓		Application of actual positions directly in the NC program
<b>Program verification graphics</b> Display modes	✓ ✓ ✓		Graphical simulation of the machining operation, even while another program is being executed Plan view / projection in three planes / 3D view, also in tilted working plane / 3D line graphics Detail zoom
<b>Programming graphics</b>	✓		In the Programming and Editing mode, the contours of entered NC blocks are rendered (2D pencil-trace graphics), even while another program is running
<b>Program-run graphics</b> Display modes	✓ ✓		Real-time graphical simulation during execution of the milling program Plan view / view in three planes / 3D view
<b>Machining time</b>	✓ ✓		Calculating the machining time in the Test Run mode of operation Display of the current machining time in the Program Run operating modes
<b>Returning to the contour</b>	✓ ✓		Mid-program startup at any block in the program and movement to the calculated nominal position for continuation of the machining operation Program interruption, contour departure and return
<b>Preset management</b>	✓		One table for saving any reference points (presets)



User function	Standard	Option	
Datum tables	✓		Multiple datum tables for storing workpiece-specific datums
Pallet tables	✓	154	Workpiece-oriented execution of pallet tables (with any number of entries for the selection of pallets, NC programs, and datums) Production process planning with Batch Process Manager
Touch probe cycles*	✓ ✓ ✓ ✓	48	Touch probe calibration Manual or automatic compensation of workpiece misalignment Manual or automatic preset setting Automatic tool and workpiece measurement KinematicsOpt: automatic measurement and optimization of the machine's kinematic model
Parallel secondary axes	✓ ✓ ✓		Compensation of movement in the secondary axes U, V, W through the principal axes X, Y, Z Movements of parallel axes included in the position display of the associated principal axis (sum display) Defining the principal and secondary axes in the NC program enables execution on different machine configurations
Conversational languages	✓		English, German, Czech, French, Italian, Spanish, Portuguese, Swedish, Danish, Finnish, Dutch, Polish, Hungarian, Russian (Cyrillic), Chinese (traditional, simplified), Slovenian, Slovak, Norwegian, Korean, Turkish, Romanian
CAD viewer	✓		Display of standardized CAD file formats on the TNC

\* Automatically enabled for HEIDENHAIN touch probes.

Accessories	
Electronic handwheels	<ul style="list-style-type: none"> <li>• <b>HR 510/HR 520:</b> portable handwheels</li> <li>• <b>HR 550:</b> portable wireless handwheel</li> <li>• <b>HR 130:</b> panel-mounted handwheel</li> </ul>
Workpiece measurement	<ul style="list-style-type: none"> <li>• <b>TS 150/TS 750:</b> compact workpiece touch probes with cable connection</li> <li>• <b>TS 260:</b> workpiece touch probe with cable connection</li> <li>• <b>TS 248:</b> workpiece touch probe with reduced deflection force</li> <li>• <b>TS 460:</b> workpiece touch probe with radio or infrared transmission</li> <li>• <b>TS 642/TS 740:</b> workpiece touch probes with infrared transmission</li> </ul>
Tool measurement	<ul style="list-style-type: none"> <li>• <b>TT 160:</b> triggering tool touch probe</li> <li>• <b>TT 460:</b> triggering tool touch probe with radio or infrared transmission</li> </ul>
Programming station	Control software for PCs for programming, archiving, and training <ul style="list-style-type: none"> <li>• Single-station license with original control keyboard</li> <li>• Single-station license with operation via virtual keyboard</li> <li>• Network license with operation via virtual keyboard</li> <li>• Demo version (operated with PC keyboard—free of charge)</li> </ul>
Software for PCs	<ul style="list-style-type: none"> <li>• <b>TeleService:</b> software for remote diagnostics, monitoring, and operation</li> <li>• <b>CycleDesign:</b> software for creating your own cycle structure</li> <li>• <b>TNCremo:</b> software for data transfer—free of charge</li> <li>• <b>TNCremoPlus:</b> software for data transfer with live-screen function</li> <li>• <b>State Monitor:</b> software for recording, evaluating, and visualizing machine data</li> </ul>

Option number	Option	Starting from NC software 81776x-	ID	Comment
0 1 2 3	Additional Axis 1 Additional Axis 2 Additional Axis 3 Additional Axis 4	01	354540-01 353904-01 353905-01 367867-01	Additional control loops 1 to 4
8	Advanced Function Set 1	01	617920-01	<b>Rotary table machining</b> <ul style="list-style-type: none"> <li>• Programming of contours for machining on a cylinder as if in two axes</li> <li>• Feed rate in mm/min</li> </ul> <b>Interpolation:</b> circular in 3 axes with tilted working plane <b>Coordinate transformation:</b> tilting the working plane, PLANE function
9	Advanced Function Set 2	01	617921-01	<b>Interpolation:</b> straight line in more than four axes (export license required) <b>3D machining</b> <ul style="list-style-type: none"> <li>• 3D tool compensation via surface normal vectors</li> <li>• Using the electronic handwheel to change the angle of the swivel head during program run without affecting the position of the tool point (TCPM = Tool Center Point Management); only with option 21</li> <li>• Keeping the tool perpendicular to the contour</li> <li>• Tool radius compensation perpendicular to the tool direction</li> <li>• Manual traverse in the active tool-axis system</li> </ul>
17	Touch Probe Functions	01	634063-01	<b>Touch probe cycles</b> <ul style="list-style-type: none"> <li>• Workpiece misalignment compensation, preset setting</li> <li>• Automatic tool and workpiece measurement</li> <li>• Touch-probe input enabling for non-HEIDENHAIN systems</li> </ul>
18	HEIDENHAIN DNC	01	526451-01	Communication with external PC applications over COM component
19	Advanced Programming Features	01	628252-01	<b>FK free contour programming</b> <b>Canned cycles</b> <ul style="list-style-type: none"> <li>• Peck drilling, reaming, boring, counterboring, centering</li> <li>• Milling internal and external threads</li> <li>• Clearing level and oblique surfaces</li> <li>• Complete machining of straight and circular slots</li> <li>• Complete machining of rectangular and circular pockets</li> <li>• Cartesian and polar point patterns and point patterns for DataMatrix code</li> <li>• Contour train, contour pocket—also with contour-parallel machining</li> <li>• Contour slot with trochoidal milling</li> <li>• Special cycles developed by the machine manufacturer can be integrated</li> </ul>
20	Advanced Graphic Features	01	628253-01	<b>Program-verification graphics, program-run graphics</b> Plan view, projection in three planes, 3D view, 3D line graphic
21	Advanced Function Set 3	01	628254-01	<b>Tool compensation</b> <ul style="list-style-type: none"> <li>• Radius-compensated contour look-ahead for up to 99 blocks (LOOK AHEAD)</li> </ul> <b>3D machining</b> <ul style="list-style-type: none"> <li>• Superimposing handwheel positioning during program run</li> </ul>
22	Pallet Management	01	628255-01	<b>Pallet management</b>
24	Gantry Axes	01	634621-01	Gantry axes via master-slave torque control
42	CAD Import	05	526450-01	Import of contours from 2D and 3D models (e.g., STEP, IGES, DXF)

## Comparison of controls

Option number	Option	Starting from NC software 81776x-	ID	Comment
46	Python OEM Process	01	579650-01	Python application on the TNC
48	KinematicsOpt	01	630916-01	Touch-probe cycles for the automatic measurement of rotary axes
49	Double-Speed Axes	01	632223-01	Short control-loop cycle times for a direct drive motor
56–61	HEIDENHAIN OPC UA NC Server	08	1291434-01 to -06	Reliable and stable interface for the connection of state-of-the-art industry applications; uncomplicated thanks to the use of standardized designs. Each of the six SIK options enables an incoming OPC UA connection via an application certificate
93	Extended Tool Management	02	676938-01	Extended tool management
133	Remote Desk. Manager	01	894423-01	Display and remote operation of external computer units (e.g., a Windows PC)
137	State Reporting	06	1232242-01	Operating states provided over the State Reporting Interface (SRI)
141	Cross Talk Comp.	01	800542-01	CTC: compensation of axis couplings
142	Pos. Adapt. Control	01	800544-01	PAC: position-dependent adaptation of the control parameters
143	Load Adapt. Control	01	800545-01	LAC: load-dependent adaptation of the control parameters
144	Motion Adapt. Control	01	800546-01	MAC: motion-dependent adaptation of the control parameters
145	Active Chatter Control	01	800547-01	ACC: active suppression of chatter during heavy machining
146	Machine Vibration Control	08	800548-01	MVC: better surfaces. The following functions are part of MVC: <ul style="list-style-type: none"> <li>• Active Vibration Damping (AVD)</li> <li>• Frequency Shaping Control (FSC)</li> </ul>
154	Batch Process Manager	05	121952-01	Depiction of pallet management in a clear format
155	Component Monitoring	06	1226833-01	Function for the monitoring of components for overload and wear
160	Integrated FS: Basic	07	1249928-01	Gen 3 exclusive: <ul style="list-style-type: none"> <li>• Enables 4 safe control loops</li> <li>• Enables functional safety (FS)</li> </ul>
161	Integrated FS: Full	07	1249929-01	Gen 3 exclusive: <ul style="list-style-type: none"> <li>• Enables the maximum number of safe control loops</li> <li>• Enables functional safety (FS)</li> </ul>
162	Add. FS Ctrl. Loop 1	07	1249930-01	Only for Gen 3: additional safe control loop 1
163	Add. FS Ctrl. Loop 2	07	1249931-01	Only for Gen 3: additional safe control loop 2
164	Add. FS Ctrl. Loop 3	07	1249932-01	Only for Gen 3: additional safe control loop 3
165	Add. FS Ctrl. Loop 4	07	1249933-01	Only for Gen 3: additional safe control loop 4
166	Add. FS Ctrl. Loop 5	07	1249934-01	Only for Gen 3: additional safe control loop 5
167	Optimized Contour Milling	07	1289547-01	Optimization of roughing processes
169	Add. FS Full	08	1319091-01	Only for Gen 3: enables remaining control loops (as with option 161). Before being able to activate and use this function, you must activate options 160 and 162 through 166

Comparison of controls	TNC 620 NC software 81760x-08	TNC 640 NC software 34059x-11
	Standard milling	High-end milling / turning / grinding
Simple machining centers (up to 8 control loops, max. 2 of which are spindles)	✓	✓
Machine tools/machining centers (up to 24 control loops, max. 4 of which are spindles)	–	✓
Milling / turning / grinding operations (up to 18 control loops + 2 spindles)	–	Option
<b>Program entry</b>		
HEIDENHAIN Klartext	✓	✓
ISO programming	✓	✓
CAD Import	Option	Option
CAD viewer	✓	✓
FK free contour programming	Option	✓
Extended milling and drilling cycles	Option	✓
OCM cycles	Option	Option
Turning cycles	–	Option
Functions for grinding	–	Option
<b>NC program memory</b>	7.7 GB (with 30 GB CFR) 2 GB (with 8 GB CFR)	21.4 GB (with 32 GB SDDR) 189 GB (with 240 GB SDDR)
<b>5-axis and high-speed machining</b>	Option	Option
<b>Block processing time</b>	1.5 ms	0.5 ms
<b>Input resolution and display step (standard)</b>	0.01 µm	0.01 µm
<b>Screen and keyboard</b>	15-inch touchscreen/ 19-inch touchscreen (portrait)	15-inch / 19-inch / 24-inch touchscreen
<b>Touchscreen</b>	✓	✓
<b>Adaptive Feed Control (AFC)</b>	–	Option
<b>Active Chatter Control (ACC)</b>	Option	Option
<b>Dynamic Collision Monitoring (DCM)</b>	–	Option
Fixture monitoring	–	Option
<b>KinematicsOpt</b>	Option	Option
<b>KinematicsComp</b>	–	Option
<b>Touch probe cycles</b>	Option	✓
<b>Pallet Management</b>	Option	✓
<b>Parallel axis function</b>	✓	✓

✓ Standard  
– Not available



# HEIDENHAIN

## DR. JOHANNES HEIDENHAIN GmbH

Dr.-Johannes-Heidenhain-Straße 5

83301 Traunreut, Germany

☎ +49 8669 31-0

FAX +49 8669 32-5061

E-mail: info@heidenhain.de

www.heidenhain.de

Vollständige und weitere Adressen siehe [www.heidenhain.de](http://www.heidenhain.de)  
For complete and further addresses see [www.heidenhain.com](http://www.heidenhain.com)

<b>DE</b>	<b>HEIDENHAIN Vertrieb Deutschland</b> 83301 Traunreut, Deutschland ☎ 08669 31-3132 FAX 08669 32-3132 E-Mail: hd@heidenhain.de	<b>DK</b>	Denmark → SE	<b>NZ</b>	<b>Llama ENGINEERING Ltd</b> Lower Hutt 5010, New Zealand E-mail: heidenhain@llamaengineering.co.nz
	<b>HEIDENHAIN Technisches Büro Nord</b> 12681 Berlin, Deutschland ☎ 030 54705-240	<b>ES</b>	<b>FARRESA ELECTRONICA S.A.</b> 08028 Barcelona, Spain www.farresa.es	<b>PH</b>	<b>MACHINEBANKS' CORPORATION</b> Quezon City, Philippines 1113 E-mail: info@machinebanks.com
	<b>HEIDENHAIN Technisches Büro Mitte</b> 07751 Jena, Deutschland ☎ 03641 4728-250	<b>FI</b>	<b>HEIDENHAIN Scandinavia AB</b> 01740 Vantaa, Finland www.heidenhain.fi	<b>PL</b>	<b>APS</b> 02-384 Warszawa, Poland www.heidenhain.pl
	<b>HEIDENHAIN Technisches Büro West</b> 44379 Dortmund, Deutschland ☎ 0231 618083-0	<b>FR</b>	<b>HEIDENHAIN FRANCE sarl</b> 92310 Sèvres, France www.heidenhain.fr	<b>PT</b>	<b>FARRESA ELECTRÓNICA, LDA.</b> 4470 - 177 Maia, Portugal www.farresa.pt
	<b>HEIDENHAIN Technisches Büro Südwest</b> 70771 Leinfelden-Echterdingen, Deutschland ☎ 0711 993395-0	<b>GB</b>	<b>HEIDENHAIN (G.B.) Limited</b> Burgess Hill RH15 9RD, United Kingdom www.heidenhain.co.uk	<b>RO</b>	<b>HEIDENHAIN Reprezentantă Romania</b> Braşov, 500407, Romania www.heidenhain.ro
	<b>HEIDENHAIN Technisches Büro Südost</b> 83301 Traunreut, Deutschland ☎ 08669 31-1337	<b>GR</b>	<b>MB Milionis Vassilis</b> 17341 Athens, Greece www.heidenhain.gr	<b>RS</b>	Serbia → BG
		<b>HR</b>	Croatia → SL	<b>RU</b>	<b>GERTNER Service</b> 119002 Moscow, Russian Federation www.heidenhain.ru
		<b>HU</b>	<b>HEIDENHAIN Kereskedelmi Képviselet</b> 1239 Budapest, Hungary www.heidenhain.hu	<b>SE</b>	<b>HEIDENHAIN Scandinavia AB</b> 12739 Skärholmen, Sweden www.heidenhain.se
<b>AR</b>	<b>NAKASE SRL.</b> B1653AOX Villa Ballester, Argentina www.heidenhain.com.ar	<b>ID</b>	<b>PT Servitama Era Toolsindo</b> Jakarta 13930, Indonesia E-mail: ptset@group.gts.co.id	<b>SG</b>	<b>HEIDENHAIN PACIFIC PTE LTD</b> Singapore 408593 www.heidenhain.com.sg
<b>AT</b>	<b>HEIDENHAIN Techn. Büro Österreich</b> 83301 Traunreut, Germany www.heidenhain.de	<b>IL</b>	<b>NEUMO VARGUS MARKETING LTD.</b> Holon, 5885948, Israel E-mail: neumo@neumo-vargus.co.il	<b>SK</b>	<b>KOPRETINA TN s.r.o.</b> 91101 Trenčin, Slovakia www.kopretina.sk
<b>AU</b>	<b>FCR MOTION TECHNOLOGY PTY LTD</b> Ravenhall Victoria 3023, Australia E-mail: sales@fcrmotion.com	<b>IN</b>	<b>HEIDENHAIN Optics &amp; Electronics India Private Limited</b> Chetpet, Chennai 600 031, India www.heidenhain.in	<b>SL</b>	<b>NAVO d.o.o.</b> 2000 Maribor, Slovenia www.heidenhain.si
<b>BE</b>	<b>HEIDENHAIN NV</b> 1760 Roosdaal, Belgium www.heidenhain.be	<b>IT</b>	<b>HEIDENHAIN ITALIANA S.r.l.</b> 20128 Milano, Italy www.heidenhain.it	<b>TH</b>	<b>HEIDENHAIN (THAILAND) LTD</b> Bangkok 10250, Thailand www.heidenhain.co.th
<b>BG</b>	<b>ESD Bulgaria Ltd.</b> Sofia 1172, Bulgaria www.esd.bg	<b>JP</b>	<b>HEIDENHAIN K.K.</b> Tokyo 102-0083, Japan www.heidenhain.co.jp	<b>TR</b>	<b>T&amp;M Mühendislik San. ve Tic. LTD. ŞTİ.</b> 34775 Y. Dudullu – Umraniye-Istanbul, Turkey www.heidenhain.com.tr
<b>BR</b>	<b>HEIDENHAIN Brasil Ltda.</b> 04763-070 – São Paulo – SP, Brazil www.heidenhain.com.br	<b>KR</b>	<b>HEIDENHAIN Korea Ltd.</b> Anyang-si, Gyeonggi-do, 14087 South Korea www.heidenhain.co.kr	<b>TW</b>	<b>HEIDENHAIN CO., LTD.</b> Taichung 40768, Taiwan www.heidenhain.com.tw
<b>BY</b>	<b>GERTNER Service</b> 220026 Minsk, Belarus www.heidenhain.by	<b>MX</b>	<b>HEIDENHAIN CORPORATION MEXICO</b> 20290 Aguascalientes, AGS., Mexico E-mail: info@heidenhain.com	<b>UA</b>	<b>GERTNER Service</b> 02094 Kiev, Ukraine www.heidenhain.ua
<b>CA</b>	<b>HEIDENHAIN CORPORATION</b> Mississauga, Ontario L5T2N2, Canada www.heidenhain.com	<b>MY</b>	<b>ISOSERVE SDN. BHD.</b> 43200 Balakong, Selangor E-mail: sales@isoserve.com.my	<b>US</b>	<b>HEIDENHAIN CORPORATION</b> Schaumburg, IL 60173-5337, USA www.heidenhain.us
<b>CH</b>	<b>HEIDENHAIN (SCHWEIZ) AG</b> 8603 Schwerzenbach, Switzerland www.heidenhain.ch	<b>NL</b>	<b>HEIDENHAIN NEDERLAND B.V.</b> 6716 BM Ede, Netherlands www.heidenhain.nl	<b>VN</b>	<b>AMS Co. Ltd</b> HCM City, Vietnam E-mail: davidgoh@amsvn.com
<b>CN</b>	<b>DR. JOHANNES HEIDENHAIN (CHINA) Co., Ltd.</b> Beijing 101312, China www.heidenhain.com.cn	<b>NO</b>	<b>HEIDENHAIN Scandinavia AB</b> 7300 Orkanger, Norway www.heidenhain.no	<b>ZA</b>	<b>MAFEMA SALES SERVICES C.C.</b> Kyalami 1684, South Africa www.heidenhain.co.za
<b>CZ</b>	<b>HEIDENHAIN s.r.o.</b> 102 00 Praha 10, Czech Republic www.heidenhain.cz				