

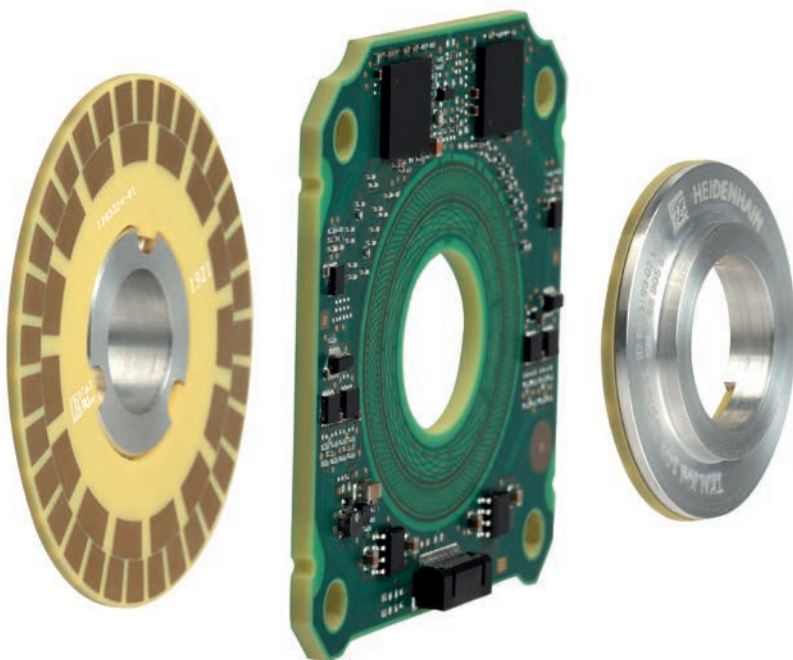

HEIDENHAIN



**Functional
Safety**

Product Information

KCI 120 Dplus

Absolute Inductive Rotary
Encoder with Additional
Functionality:

Position measurement of
output side

With additional measures:
suitable for safety-related
applications with up to SIL 3

05/2021

Position measurement

Specifications	KCI 120 Dplus singletum Output side (Encoder A)	KCI 120 Dplus singletum Motor side (Encoder B)
Functional safety for applications with up to	As a single-encoder system for monitoring and control-loop functions: <ul style="list-style-type: none"> • SIL 2 as per EN 61508 (further basis for testing: EN 61800-5-2) • Category 3, PL d as per EN ISO 13849-1:2015 With additional measures as per document 1000344, suitable for safety-related applications with up to SIL 3 or Category 4, PL e Safe in the singleturn range of both axes	
PFH (each encoder)	<i>SIL 2</i> : $\leq 15 \cdot 10^{-9}$ (probability of dangerous failure per hour) <i>SIL 3</i> : $\leq 2 \cdot 10^{-9}$	
Safe position ¹⁾	<i>Device</i> : $\pm 0.44^\circ$ (safety-related measuring step $SM = 0.176^\circ$) <i>Mechanical coupling for shaft</i> : 0° (fault exclusion for the loosening of the shaft coupling and stator coupling; designed for accelerations at the stator of $\leq 400 \text{ m/s}^2$; at the rotor: $\leq 600 \text{ m/s}^2$)	
Shaft	Hub with an inside diameter of 15.7 mm	Hub with an inside diameter of 19 mm
Shaft speed	$\leq 6000 \text{ rpm}$	$\leq 15000 \text{ rpm}$
Moment of inertia of rotor	$5.5 \cdot 10^{-6} \text{ kgm}^2$ (without supporting ball bearing)	$2.0 \cdot 10^{-6} \text{ kgm}^2$
Axial motion ²⁾	$\pm 0.3 \text{ mm}$	$\pm 0.5 \text{ mm}$
Position values per revolution	1048576 (20 bits)	524288 (19 bits)
System accuracy	$\pm 40''$	$\pm 120''$

¹⁾ Further tolerances may arise in the subsequent electronics after position value comparison (contact mfr. of subsequent electronics)

²⁾ Including thermal linear expansion and mounting tolerance

Mounting

Mounting and protection rating

Mounting and protection rating

The KCI 120Dplus is mounted by press-fitting the two disk/hub assemblies and attaching the scanning unit. The disk/hub assemblies are press-fit onto the respective shaft, and the scanning unit is mounted to the mating surface through the four holes.

The press-fitting process may be performed only once for each disk/hub assembly. When press-fitting onto the shafts, the material properties and the conditions for the customer's mating surfaces stated in the relevant documents must be adhered to for the intended purposes. These requirements must also be followed when press-fitting new disk/hub assemblies onto customer shafts that have already been used. Once the lower limit of the press-fit force has been exceeded, the press-fit force being applied must remain within the specified range for the rest of the procedure, including until the end position is reached.

If the application features functional safety, then, after the mounting or installation of the encoder onto the mating surface, the device must be protected from at least the ingress of solid foreign objects in accordance with an IP6x protection rating, as well as from the ingress of liquids (the protection rating for liquids depends on the application, e.g., IPx5: protection from water jets). If exposure to contamination, such as dust and liquids, can be excluded, then a protection rating of at least IP40 when mounted is sufficient.

Further information:

Follow the measures for *electromagnetic compatibility* described in the *General electrical information* in the *Interfaces of HEIDENHAIN Encoders* brochure to ensure disturbance-free operation.

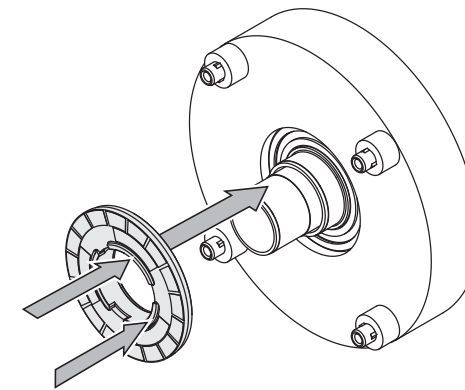

Disk/hub assembly (Encoder B)

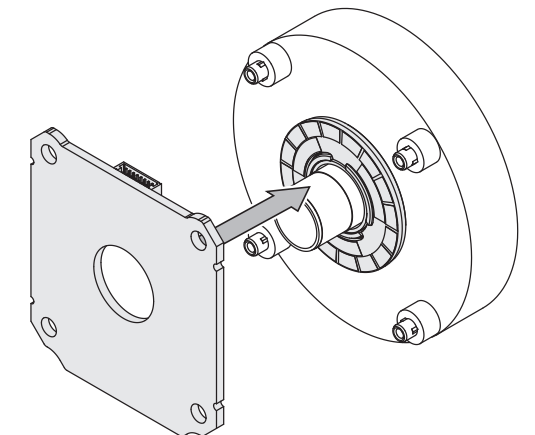

Scanning unit

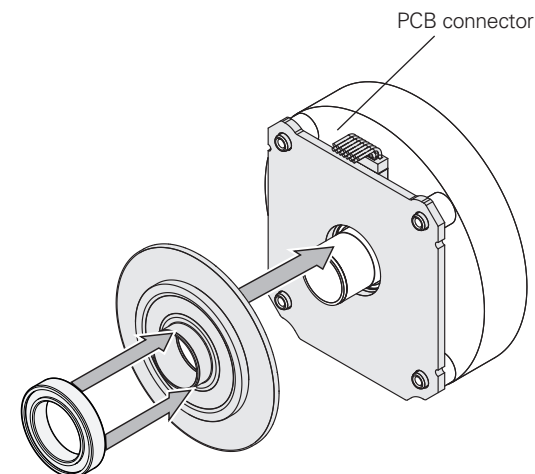

Disk/hub assembly (Encoder A)
Optional: press-fitting of a supporting ball bearing

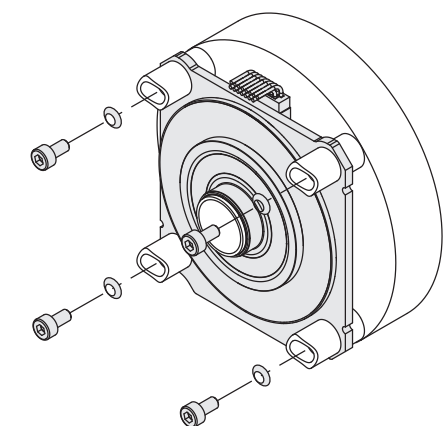

Graduated disks and scanning unit (mounted)

Mechanical fault exclusion

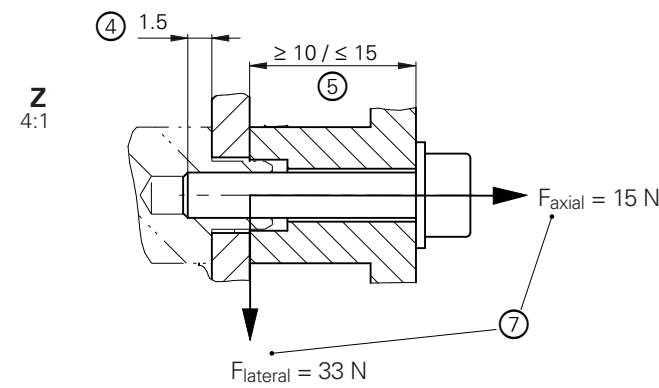
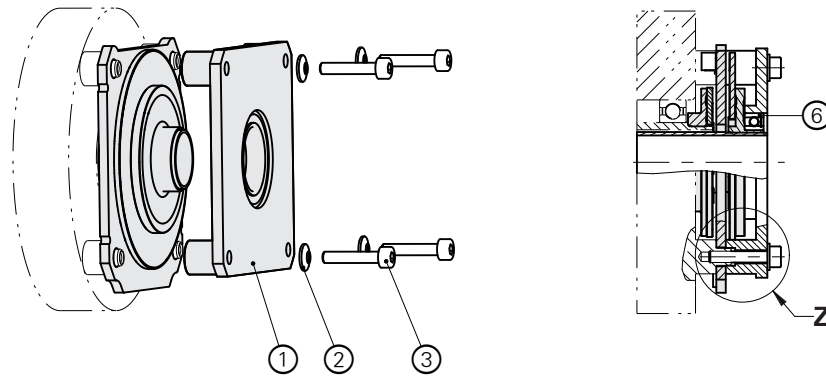

- 1 = Supporting flange for the stator connection:
Material in accordance with the table at right ("Customer stator" column)
Maximum permissible total mass (including additional parts): 0.130 kg
Surface roughness at the joints: $R_z \leq 16 \mu\text{m}$
- 2 = Spring washer: DIN 6796 - 3 - FSt (4x)
Ensure correct positioning with the convex side facing the screw head
- 3 = Screw: M3 ISO 4762 - 8.8 - MKL (4x)
Tightening torque: 1.0 Nm ± 0.1 Nm
- 4 = Minimum engagement depth starting at the surface of the scanning unit; see also the dimension drawing
- 5 = Board thickness at screw connection
- 6 = Optional supporting ball bearing for measured shaft;
Service life and permissible bearing load must not be exceeded;
The ball bearing must not be blocked
- 7 = Maximum permissible forces acting on the screw connection
- To be applied to at least two diagonally opposing screws with a spring washer, which must immediately adjoin the supporting flange \odot
- Valid for all operating conditions. Additionally arising forces (e.g., from a vibration load and torque) must be taken into account:
 $F_{\text{lateral}} = 33 \text{ N}$
 $F_{\text{axial}} = 15 \text{ N}$

mm

 Tolerancing ISO 8015
 ISO 2768 - m H
 < 6 mm: $\pm 0.2 \text{ mm}$

For the fault exclusion design for functional safety, the following material properties and conditions for the mating surfaces are assumed.

Rotary encoders may exert a torque of up to 1 Nm on the mating shaft. The customer-side mechanical design must be made for this load.

	Customer motor shaft	Customer output shaft	Customer stator
Material	Hardenable wrought aluminum alloy		Aluminum
Tensile strength R_m	$\geq 260 \text{ N/mm}^2$	$\geq 215 \text{ N/mm}^2$	$\geq 220 \text{ N/mm}^2$
Yield strength $R_{p0.2}$ or yield point R_e	$\geq 240 \text{ N/mm}^2$	$\geq 160 \text{ N/mm}^2$	Not applicable
Shear strength τ_a	Not applicable		$\geq 130 \text{ N/mm}^2$
Interface pressure p_G	Not applicable		$\geq 250 \text{ N/mm}^2$
Modulus of elasticity E (at 20 °C)	69 kN/mm ² to 71 kN/mm ²		70 kN/mm ² to 75 kN/mm ²
Coefficient of thermal expansion α_{therm} (at 20 °C)	$23 \cdot 10^{-6} \text{ K}^{-1}$ to $24 \cdot 10^{-6} \text{ K}^{-1}$		$\leq 25 \cdot 10^{-6} \text{ K}^{-1}$
Surface	Anodized coating permissible		
Surface roughness R_z	$\leq 6.3 \mu\text{m}$		$\leq 16 \mu\text{m}$
Friction values	Lubrication at the joint surfaces is recommended.		Mounting surfaces must be clean and free of grease. Use screws and washers in their condition as delivered.
Tightening procedure	Use a signal-emitting torque wrench as per DIN EN ISO 6789; accuracy: $\pm 6 \%$		
Mounting temperature	15 °C to 35 °C		

Mounting tool

To avoid damage to the cable, use the mounting aid to disconnect the cable assembly. Apply pulling force only to the connector of the cable assembly and not to the wires.



ID 1075573-01

Mounting accessories

Screws: M3 ISO 4762 - 8.8 MKL and spring washers: DIN 6796 - 3 - FSt.

Instructions for use: use screws with material bonding anti-rotation lock as per DIN 26727 (see the *Rotary Encoders* brochure, under *General mechanical information*). Fastening screws and spring washers must be ordered separately.

For more mounting information and mounting aids, see the Mounting Instructions and the *Encoders for Servo Drives* brochure. The mounting quality can be tested with the PWM 21 and the ATS software (see document ID 1082415).

Integrated temperature evaluation

Each axis of these rotary encoders features an internal temperature sensor integrated into the encoder electronics. The digitized temperature value is transmitted purely serially via the EnDat protocol. Please bear in mind that this measurement and transmission of the temperature is not safe in terms of functional safety.

With regard to the internal temperature sensor, the rotary encoder supports the two-stage cascaded signaling of a temperature exceedance. This consists of an EnDat warning and an EnDat error message.

In accordance with the EnDat specification, an EnDat warning (EnDat memory area "Operating status," word 1 "Warnings," bit 2¹ "Temperature exceeded") is output when the warning threshold for the temperature exceedance of the internal temperature sensor is reached. This warning threshold for the internal temperature sensor is stored in the EnDat memory area "Operating parameters," word 6 "Trigger threshold warning bit for excessive temperature" of each axis, and can be individually adjusted.

A device-specific default value is saved here before shipping. The temperature measured by the internal temperature sensor is higher by a device-specific and application-specific amount than the temperature at the measuring point, as shown in the dimension drawing.

Each axis of the rotary encoders features a further non-adjustable trigger threshold for the "Temperature exceeded" EnDat error message of the internal temperature sensor. When this is reached, an EnDat error message is output (EnDat memory area "Operating status," word 0 "Error messages," bit 2² "Position" and in additional data 2 "Operating status error sources," bit 2⁶ "Temperature exceeded"). This trigger threshold may vary depending on the encoder and is stated in the specifications.

HEIDENHAIN recommends adjusting the warning threshold based on the application such that this threshold is sufficiently below the trigger threshold for the "Temperature exceeded" EnDat error message. Compliance with the temperature at the measuring point is required for adherence to the encoder's intended and proper use.

Diagnostics, inspection, and testing devices

HEIDENHAIN encoders provide all of the information needed for commissioning, monitoring, and diagnostics. The type of information available depends on whether the encoder is incremental or absolute and on which interface is being used.

Absolute encoders employ serial data transmission. The signals are extensively monitored within the encoder. The monitoring results (particularly valuation numbers) can be transmitted to the subsequent electronics along with the position values via the serial interface (**digital diagnostics interface**). The following information is available:

- Error message: position value is not reliable
- Warning: an internal functional limit of the encoder has been reached
- Valuation numbers:
 - Detailed information about the encoder's function reserve
 - Identical scaling for all HEIDENHAIN encoders
 - Cyclic reading capability

The subsequent electronics are able to evaluate the current status of the encoder with low resource expenditure, including in closed-loop operation.

For the analysis of these encoders, HEIDENHAIN offers the appropriate PWM inspection devices and PWT testing devices. Based on how these devices are integrated, a distinction is made between two types of diagnostics:

- Encoder diagnostics: the encoder is connected directly to the testing or inspection device, thereby enabling a detailed analysis of encoder functions.

- Monitoring mode: the PWM inspection device is interposed within the closed control loop (via suitable testing adapters as needed). This enables real-time diagnosis of the machine or equipment during operation. The available functions depend on the interface.

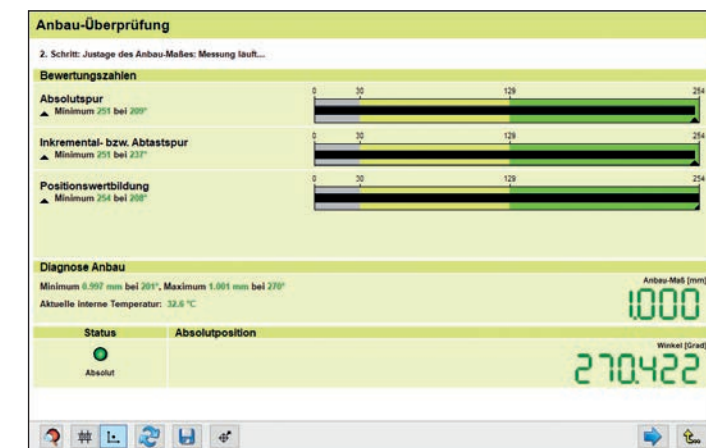

Mounting accuracy with the PWM 21 and the ATS software

Electrical resistance

Check the electrical resistance between the customer-side stator and both customer-side shafts.
Nominal value: < 1 ohm

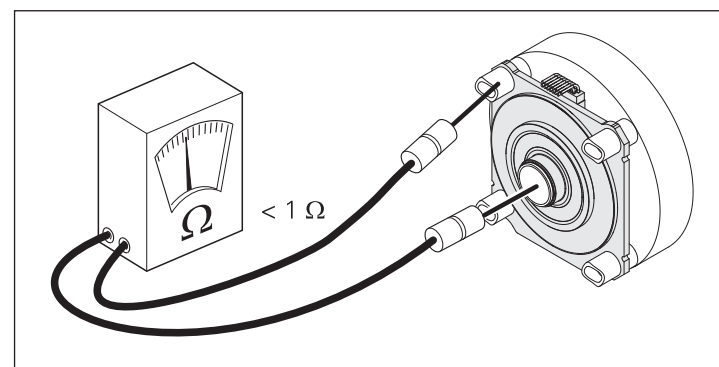

PWM 21

The PWM 21 phase-angle measuring unit, in conjunction with the included ATS adjusting and testing software, serves as an adjusting and testing package for the diagnosis and adjustment of HEIDENHAIN encoders.



For more information, see the *PWM 21/ATS Software* Product Information document.

	PWM 21
Encoder input	<ul style="list-style-type: none"> • EnDat 2.1, EnDat 2.2, or EnDat 3 (absolute value with or without incremental signals) • DRIVE-CLiQ • FANUC Serial Interface • Mitsubishi high speed interface • Yaskawa Serial Interface • Panasonic serial interface • SSI • 1 V_{pp}/TTL/11 μA_{pp} • HTL (via signal adapter)
Interface	USB 2.0
Supply voltage	AC 100 V to 240 V or DC 24 V
Dimensions	258 mm × 154 mm × 55 mm

DRIVE-CLiQ is a registered trademark of Siemens AG.

Electrical connection

When a special testing cable is connected to the PWM 21 diagnostic and testing device, Encoder A (output side) is connected. In order to connect Encoder B (motor side), a different special testing cable must be used.

HEIDENHAIN offers two testing cables for this purpose. As a result, either a testing cable for the output-side encoder or a testing cable for the motor-side encoder can be connected to the PWM 21 as needed.

Pin layout of the testing cables

Testing cable for connection to Encoder A: 1311046-xx

15-pin PCB connector					Serial data transmission (Encoder A)			
15	14	12	13	11	7	8	9	10
0V	Sensor 0V	U _P	Sensor U _P	DATA A	DATA A	CLOCK A	CLOCK A	
White/Green	White	Brown/Green	Blue	Gray	Pink	Violet	Yellow	

U_P = Power supply
Vacant pins or wires must not be used!

Testing cable for connection to Encoder B: 1311047-xx

15-pin PCB connector					Serial data transmission (Encoder B)			
15	14	12	13	11	1	2	3	4
0V	Sensor 0V	U _P	Sensor U _P	DATA B	DATA B	CLOCK B	CLOCK B	
White/Green	White	Brown/Green	Blue	Gray	Pink	Violet	Yellow	

U_P = Power supply
Vacant pins or wires must not be used!

Pin layout for the rotary encoder

15-pin PCB connector				Serial data transmission (Encoder A)				Serial data transmission (Encoder B)				
15	14	12	13	11	7	8	9	10	1	2	3	4
0V	Sensor 0V	U _P	Sensor U _P	DATA A	DATA A	CLOCK A	CLOCK A		DATA B	DATA B	CLOCK B	CLOCK B

U_P = Power supply
Vacant pins or wires must not be used!
The subsequent electronics must have a common ground reference!

Cable length > 0.5 m:
To prevent crosstalk, the two EnDat interfaces must be separately shielded from each other. The cable sold by meter with ID 1347450-xx (PUR, Ø 3.7 mm) can be used for this. Two cables must be attached to the PCB connector in order to transmit the EnDat signals separately. Only one cable is used for the power supply. When using the cable sold by meter with ID 1347450-xx, the general information in the *Cables and Connectors* brochure must be noted; use of the cables at temperatures of up to 100 °C is possible provided that the exposure to hydrolysis and media is low.

Cable length ≤ 0.5 m:
When single wires up to a maximum length of 0.5 m are used, each data and clock wire combination must be implemented as a twisted wire pair in order to avoid coupled interferences. As an alternative, the cable with ID 605090-51 (EPG, Ø 4.5 mm) and a length of 0.3 m can be used. The general information in the *Cables and Connectors* brochure must be noted.

HEIDENHAIN

DR. JOHANNES HEIDENHAIN GmbH
Dr.-Johannes-Heidenhain-Straße 5
83301 Traunreut, Germany
+49 8669 31-0
+49 8669 32-5061
E-mail: info@heidenhain.de

www.heidenhain.de

This Product Information document supersedes all previous editions, which thereby become invalid. The basis for ordering from HEIDENHAIN is always the Product Information document edition valid when the order is placed.

Further information:

- Comply with the requirements described in the following documents to ensure correct and intended operation:
- Brochure: *Encoders for Servo Drives* 208922-xx
 - Brochure: *Interfaces of HEIDENHAIN Encoders* 1078628-xx
 - Brochure: *Cables and Connectors* 1206103-xx
 - Mounting Instructions: KCI 120 Dplus 1336024-xx
 - Product Notes for JAE connecting element 576762-xx (sheet 1)
 - Technical Information: *Safety-Related Position Measuring Systems* 596632-xx
 - For implementation in a safe control or frequency inverter:
Specification: 533095-xx
Specification: *Supplementary Catalog of Measures* (SIL 3, PLe) 1000344-xx
 - Setup instructions 1082415-xx