

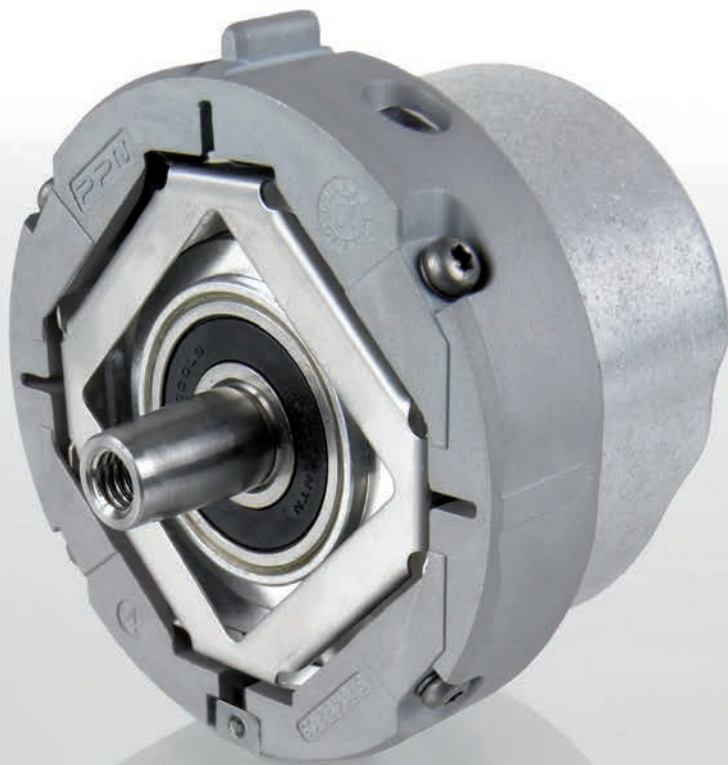

HEIDENHAIN



**Encoders for
Servo Drives**

This brochure is not an exhaustive overview of the HEIDENHAIN product program, but rather provides a selection of **encoders designed for use on electric motors**.

The **selection tables** provide an overview of all HEIDENHAIN encoders intended for use on electric motors, along with the most relevant specifications. The descriptions of **technical features** contain basic information about the use of rotary encoders, angle encoders, and linear encoders on electric motors.

The **mounting information** and detailed **specifications** refer to **rotary encoders** developed specifically for servomotors. For information about other rotary encoders, please refer to the appropriate product documentation.



Brochure
Rotary Encoders



Product Overview
Rotary Encoders for the Elevator Industry



Brochure
Angle Encoders With Integral Bearing



Product Overview
Rotary Encoders For Potentially Explosive Atmospheres



Brochure
Modular Angle Encoders With Optical Scanning



Brochure
Modular Angle Encoders With Magnetic Scanning



Further information:

Regarding the **linear encoders** and **angle encoders** listed in the selection tables, please refer to the respective product documentation to find detailed descriptions, including mounting information, specifications, and dimensions.



Brochure
Linear Encoders For Numerically Controlled Machine Tools



Brochure
Exposed Linear Encoders



Further information:

Detailed descriptions of all available interfaces, as well as general electrical information, can be found in the *Interfaces of HEIDENHAIN Encoders* brochure.

This brochure supersedes all previous editions, which thereby become invalid. The basis for ordering from HEIDENHAIN is always the brochure edition valid when the order is made.

Standards (ISO, EN, etc.) apply only where explicitly stated in the brochure.

Contents

Overview		
	Information about the selection tables	6
	Rotary encoders for mounting inside motors	8
	Rotary encoders for mounting on motors	12
	Angle encoders for built-in and hollow-shaft motors	18
	Exposed linear encoders for linear motors	20
	Sealed linear encoders for linear motors	22
Technical features and mounting information		
	Rotary encoders and angle encoders for DC and three-phase AC motors	24
	HMC 6	26
	Safety-related position measuring systems	28
	Measuring principles	30
	Measuring accuracy	33
	Mechanical design types and mounting	36
	General information	46
	General mechanical information	47
Specifications		
<i>Rotary encoders with integral bearing</i>	ECN/EQN 1100 series	54
	ERN 1023	56
	ERN 1123	58
	ECN/EQN 1300 series	60
	ECN/EQN 1300S series	62
	ECN/EQN 400 series	64
	ERN 1300 series	66
	EQN/ERN 400 series	68
	ERN 401 series	70
	<i>Rotary encoders without integral bearing</i>	ECI/EQI 1100 series
ECI/EBI 1100 series		76
ECI/EBI/EQI 1300 series		78
ECI/EQI 1300S series		80
ECI/EBI 100 series		82
ECI 4010, EBI 4010, ECI 4090S –With Ø 90 mm hollow shaft –With Ø 180 mm hollow shaft		84
ERO 1200 series		88
ERO 1400 series		90
Electrical connection		
	Interfaces	92
	Cables and connecting elements	104
	Interface electronics	114
	Diagnostics, and inspection and testing equipment	116

Encoders for electric motors

Controller systems for electric motors require encoders that provide feedback for the position and speed controllers, and for electronic commutation.

Encoder attributes have a critical impact on important motor characteristics, such as:

- Positioning accuracy
- Speed stability
- Bandwidth, and therefore command and disturbance behavior
- Power dissipation
- Size
- Acoustic noise
- Safety

Digital position control and speed control

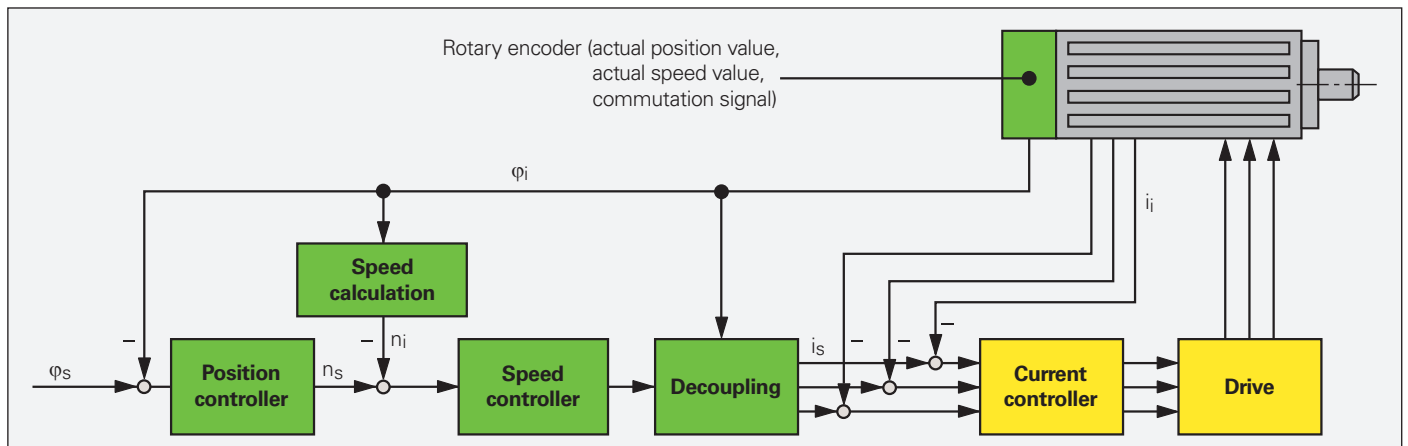

HEIDENHAIN can provide a well-matched solution for rotary and linear motors used in a variety of applications:

- Absolute and incremental rotary encoders with and without commutation tracks
- Absolute and incremental angle encoders
- Absolute and incremental linear encoders
- Absolute and incremental modular encoders

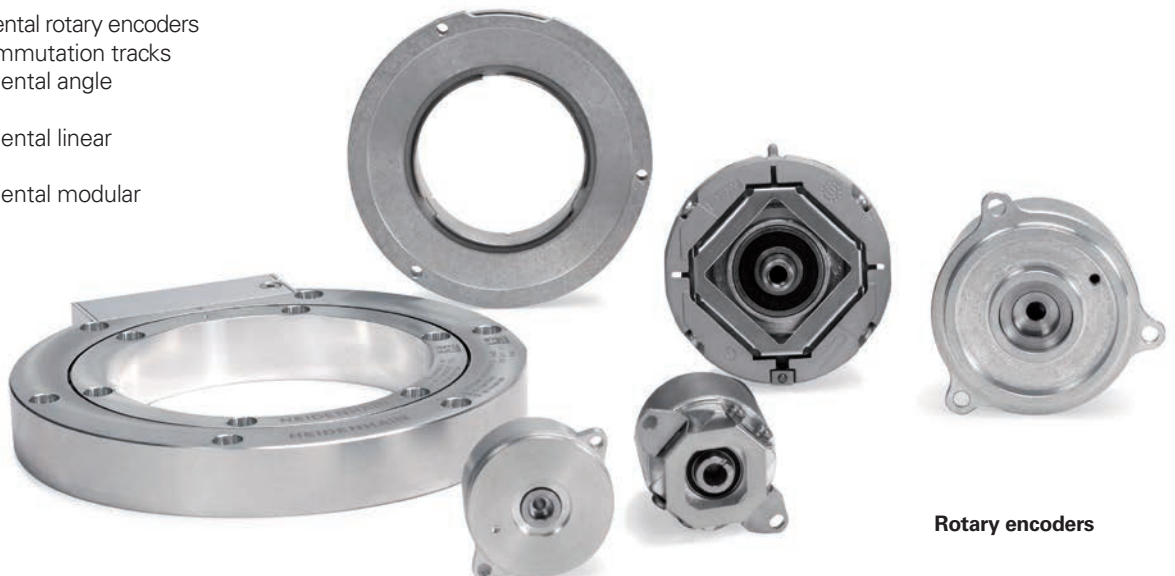

All of the HEIDENHAIN encoders listed in this brochure have been designed for minimized mounting and cabling effort on the part of the motor manufacturer. Overall rotary motor length can also be kept low. The special design of some encoders can even eliminate the need for safety devices such as limit switches.

Motor for digital drive systems (digital position and speed control)

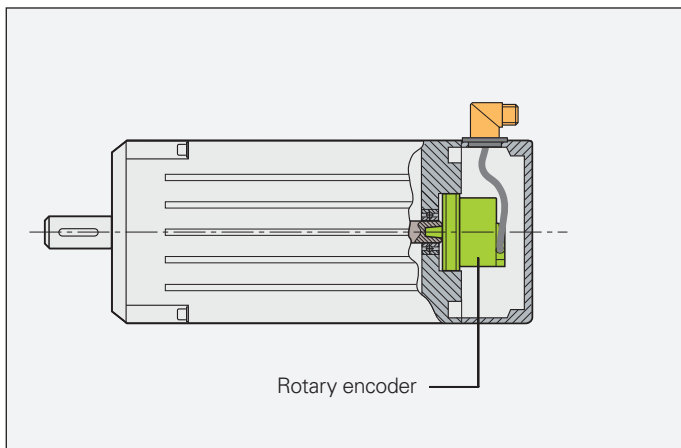

Angle encoders



Linear encoders

Information about the selection tables

The selection tables on the following pages list the encoders that are suitable for each motor design. Each table contains encoders with different dimensions and output signals for the various motor types (DC or three-phase AC motors).

Rotary encoders for mounting on motors

Rotary encoders for motors with forced ventilation are either mounted on the motor housing or installed within it. These rotary encoders are often exposed to the motor's unfiltered forced-air stream and must therefore possess a high protection class of IP64 or better. The permissible operating temperature seldom exceeds 100 °C.

The selection table contains the following encoders:

- Rotary encoders with a mounted **stator coupling** with a high natural frequency—virtually eliminating any limits on motor bandwidth
- Rotary encoders for **separate shaft couplings**, thus particularly well suited for electrically **isolated mounting**
- Absolute rotary encoders with purely digital data transmission or additional sinusoidal TTL or HTL incremental signals
- Incremental rotary encoders with high-quality **sinusoidal output signals** for digital speed control
- Incremental rotary encoders with **TTL- or HTL-compatible output signals**
- Information on functional-safety rotary encoders available as safety-related position measurement systems

For the selection table, see page 12

Rotary encoders for mounting inside motors

In motors without forced ventilation, the rotary encoder is installed inside the motor housing. As a result, the encoder does not require a high protection class. Nevertheless, the operating temperature inside the motor housing can reach 100 °C or more.

The selection table contains the following encoders:

- Absolute rotary encoders for operating temperatures of up to 115 °C and incremental rotary encoders for **operating temperatures** of up to 120 °C
- Rotary encoders with a mounted **stator coupling** with a high natural frequency—virtually eliminating any limits on motor bandwidth
- Absolute rotary encoders with **purely digital data transmission** (suitable for the **HMC 6** single-cable solution) or additional sinusoidal incremental signals
- Incremental rotary encoders for digital speed control, featuring high-quality **sinusoidal output signals**, even under high operating temperatures
- Incremental rotary encoders with an additional **commutation signal** for synchronous motors
- Incremental rotary encoders with **TTL-compatible output signals**
- Information on functional-safety rotary encoders available as safety-related position measurement systems

For the selection table, see page 8

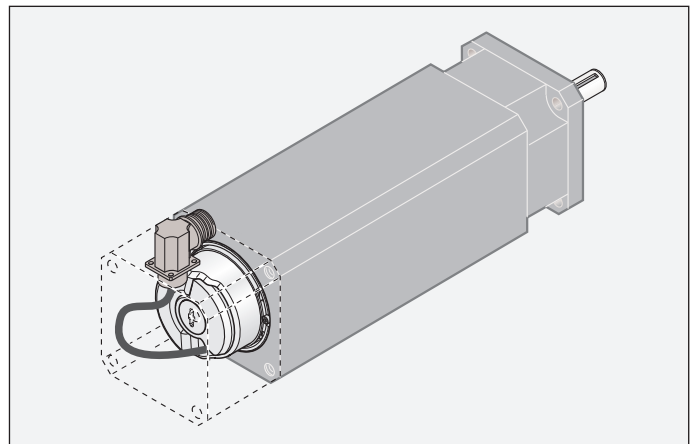
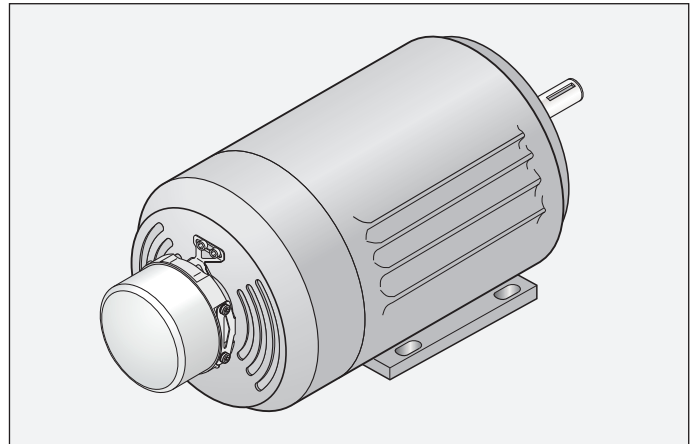

Rotary encoders, modular encoders, and angle encoders for built-in and hollow-shaft motors

The rotary encoders and angle encoders for these motors feature **hollow through shafts**, allowing supply lines to be routed through the hollow shaft of both the motor and the encoder. Depending on the operating conditions, these encoders must either have an IP66 rating or be protected from contamination through the machine design (as with optical modular encoders).

The selection table contains the following encoders:

- Encoders with high-quality **absolute and/or incremental output signals**
- Angle encoders and modular encoders with the measuring standard on an aluminum or steel drum for **shaft speeds of up to 42000 rpm**
- Encoders with an integral bearing and stator coupling, or modular versions
- Encoders with **good acceleration performance** for high control-loop bandwidth

For the selection table, see page 18

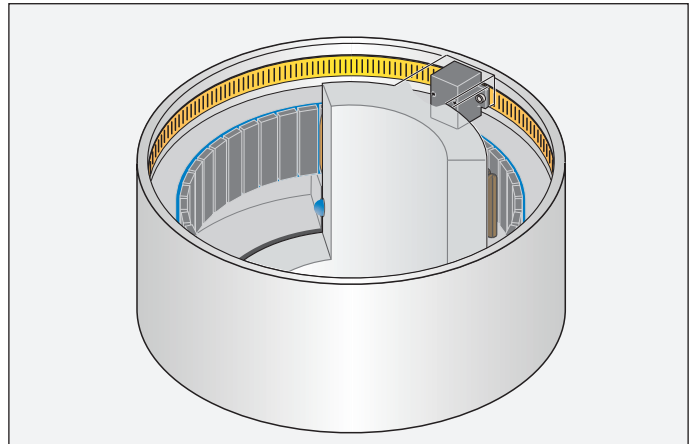

Linear encoders for linear motors

Linear encoders installed on linear motors provide actual-value feedback for the position and speed controllers. These encoders have a decisive impact on the control characteristics of the linear motor. The linear encoders recommended for this type of application exhibit the following characteristics:

- Low position error during acceleration in the direction of measurement
- High tolerance to acceleration and lateral vibration
- Design suitability for high shaft speeds
- Absolute position information with purely digital data transmission or high-quality sinusoidal incremental signals

Exposed linear encoders are characterized by:

- Higher accuracy grades
- Higher traversing speeds
- Contact-free scanning (i.e., no friction between scanning head and scale)

Exposed linear encoders are suitable for applications in clean environments (e.g., on measuring machines or production equipment in the semiconductor industry).

For the selection table, see page 20

Sealed linear encoders feature the following characteristics:

- High protection class
- Easy mounting

Sealed linear encoders are thus suitable for applications in high-contamination environments (e.g., on machine tools).



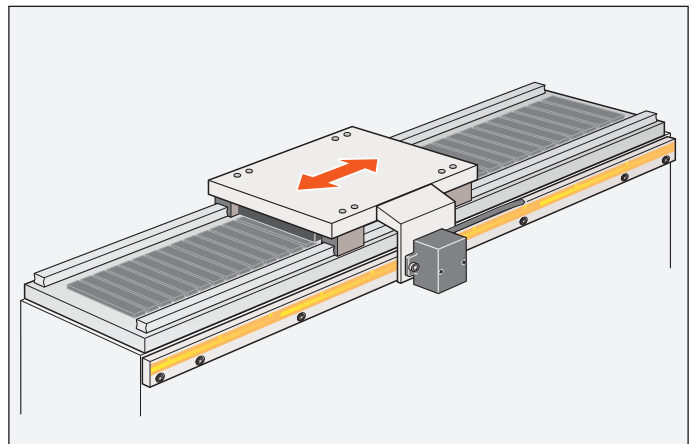

For the selection table, see page 22



Selection guide

Rotary encoders for mounting inside motors

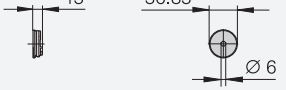
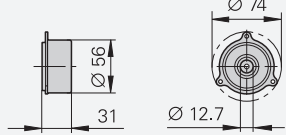
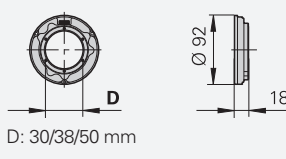
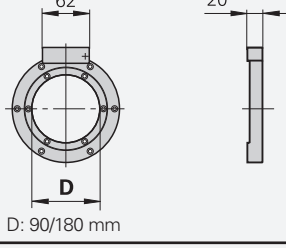

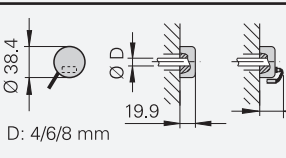
Protection class: up to IP40 (EN 60529)

Series	Main dimensions	Mechanically permissible shaft speed	Natural frequency f_N (typical) of the coupling	Maximum operating temperature	Supply voltage
Rotary encoders without integral bearing					
ECI/EQI 1100		≤ 15000 rpm/ ≤ 12000 rpm	–	110 °C	DC 3.6 V to 14 V
ECI/EQI 1100 with synchro flange					
ECI/EBI 1100				115 °C	
ECI/EBI/EQI 1300		≤ 15000 rpm/ ≤ 12000 rpm	–	115 °C	DC 3.6 V to 14 V
				100 °C	DC 10 V to 28.8 V
ECI/EBI 100		≤ 6000 rpm	–	115 °C	DC 3.6 V to 14 V
ECI/EBI 4000		≤ 6000 rpm	–	115 °C	DC 3.6 V to 14 V
				100 °C	DC 10 V to 28.8 V
ERO 1200		≤ 25000 rpm	–	100 °C	DC 5 V ±0.5 V
ERO 1400		≤ 30000 rpm	–	70 °C	DC 5 V ±0.5 V
					DC 5 V ±0.25 V
					DC 5 V ±0.5 V

¹⁾ Also available with functional safety

²⁾ After internal 5/10/20/25-fold interpolation

DRIVE-CLiQ is a registered trademark of Siemens AG.

Signal periods per revolution	Positions per revolution	Distinguishable revolutions	Interface	Model	Further information
–	524 288 (19 bits)	–/4096	EnDat 2.2/22	ECI 1119¹⁾/EQI 1131¹⁾	Page 72
	262 144 (18 bits)	–/65 536 ³⁾		ECI 1118/EBI 1135	Page 76
–	524 288 (19 bits)	–/4096	EnDat 2.2/22	ECI 1319¹⁾/EBI 1335¹⁾/EQI 1331¹⁾	Page 78
			DRIVE-CLiQ	ECI 1319S/EQI 1331 S	Product Information document
32	524 288 (19 bits)	–	EnDat 2.1/01 with $\sim 1 V_{PP}$	ECI 119	Page 82
–		–/65 536 ³⁾	EnDat 2.2/22	ECI 119/EBI 135	
–	1 048 576 (20 bits)	–/65 536 ³⁾	EnDat 2.2/22	ECI/EBI 4010¹⁾	Page 84
		–	DRIVE-CLiQ	ECI 4090S¹⁾	
1024/2048	–		 TTL	ERO 1225	Page 88
			$\sim 1 V_{PP}$	ERO 1285	
512/1000/1024	–		 TTL	ERO 1420	Page 90
5000 to 37 500 ²⁾			 TTL	ERO 1470	
512/1000/1024			$\sim 1 V_{PP}$	ERO 1480	

³⁾ Multiturn functionality via battery-buffered revolution counter

Series	Main dimensions	Mechanically permissible shaft speed	Natural frequency f_N (typical) of the coupling	Maximum operating temperature	Supply voltage
Rotary encoders with integral bearing and mounted stator coupling					
ECN/EQN/ ERN 1100		≤ 12000 rpm	1000 Hz	115 °C	DC 3.6 V to 14 V
				95 °C	DC 10 V to 28.8 V
		≤ 6000 rpm	1600 Hz	90 °C	DC 5 V \pm 0.5 V
ECN/EQN/ ERN 1300		≤ 15000 rpm/ ≤ 12000 rpm	1800 Hz	115 °C	DC 3.6 V to 14 V
		≤ 15000 rpm		120 °C <i>ERN 1381/4096:</i> 80 °C	DC 5 V \pm 0.5 V
				100 °C	DC 10 V to 28.8 V

¹⁾ Also available with functional safety

DRIVE-CLiQ is a registered trademark of Siemens AG.

Signal periods per revolution	Positions per revolution	Distinguishable revolutions	Interface	Model	Further information
512	8192 (13 bits)	-/4096	EnDat 2.2/01 with \sim 1 V _{PP}	ECN 1113/EQN 1125	Page 54
-	8388608 (23 bits)		DRIVE-CLiQ	ECN 1123S/EQN 1135S	
500 to 8192	3 block commutation signals		\square TTL	ERN 1123	Page 58
512/2048	8192 (13 bits)	-/4096	EnDat 2.2/01 with \sim 1 V _{PP}	ECN 1313/EQN 1325	Page 60
-	33554432 (25 bits)		EnDat 2.2/22	ECN 1325¹⁾/EQN 1337¹⁾	
1024/2048/4096	-	3 block commutation signals	\square TTL	ERN 1321	Page 66
512/2048/4096	-			ERN 1326	
2048	Z1 track for sine commutation	\sim 1 V _{PP}	ERN 1381		
-	16777216 (24 bits)	-/4096	DRIVE-CLiQ	ERN 1387	
-	16777216 (24 bits)	-/4096	DRIVE-CLiQ	ECN 1324S/EQN 1336S	Page 62 Product Information document

Rotary encoders for mounting on motors

Protection class: up to IP64 (EN 60529)

Series	Main dimensions	Mechanically permissible shaft speed	Natural frequency f_N (typical) of the coupling	Maximum operating temperature	Supply voltage
Rotary encoders with integral bearing and mounted stator coupling					
ECN/ERN 100		$\varnothing \leq 30 \text{ mm}$: $\leq 6000 \text{ rpm}$ $\varnothing > 30 \text{ mm}$: $\leq 4000 \text{ rpm}$	1000 Hz	100 °C	DC 3.6 V to 14 V
				85 °C	DC 5 V ± 0.5 V DC 10 V to 30 V
ECN/EQN/ERN 400	<p>Stator coupling for plane surfaces</p> <p>Universal stator coupling</p>	$\leq 6000 \text{ rpm}$ <i>With two shaft clampings (only for hollow through shaft):</i> $\leq 12000 \text{ rpm}$	<i>Stator coupling for plane surfaces:</i> 1500 Hz <i>Universal stator coupling:</i> 1400 Hz	100 °C	DC 3.6 V to 14 V
					DC 4.75 V to 30 V
					DC 5 V ± 0.5 V
				70 °C	DC 10 V to 30 V
	100 °C	DC 5 V ± 0.5 V			
ECN/EQN/ERN 400	<p>Stator coupling for plane surfaces</p>	$\leq 6000 \text{ rpm}$ <i>With two shaft clampings (only for hollow through shaft):</i> $\leq 12000 \text{ rpm}$	<i>Stator coupling for plane surfaces:</i> 1500 Hz <i>Universal stator coupling:</i> 1400 Hz	100 °C	DC 10 V to 30 V
					DC 4.75 V to 30 V
					DC 3.6 V to 14 V
					DC 10 V to 28.8 V
ECN/EQN/ERN 400	<p>Expanding ring coupling</p> <p>Plane-surface coupling</p>	$\leq 15000 \text{ rpm}$ / $\leq 12000 \text{ rpm}$ $\leq 15000 \text{ rpm}$	<i>Expanding ring coupling:</i> 1800 Hz <i>Plane-surface coupling:</i> 400 Hz	100 °C	DC 3.6 V to 14 V
				DC 5 V ± 0.5 V	
				DC 5 V ± 0.25 V	

¹⁾ Also available with functional safety

DRIVE-CLiQ is a registered trademark of Siemens AG.

	Signal periods per revolution	Positions per revolution	Distinguishable revolutions	Interface	Model	Further information
	2048	8192 (13 bits)	–	EnDat 2.2/01 with $\sim 1 V_{PP}$	ECN 113	Brochure: Rotary Encoders
	–	33554432 (25 bits)		EnDat 2.2/22	ECN 125	
	1000 to 5000	–		\square TTL/ $\sim 1 V_{PP}$	ERN 120/ERN 180	
				\square HTL	ERN 130	
	512/2048	8192 (13 bits)	–/4096	EnDat 2.2/01 $\sim 1 V_{PP}$	ECN 413/EQN 425	Brochure: Rotary Encoders
	–	33554432 (25 bits)		EnDat 2.2/22	ECN 425/EQN 437	
	512	8192 (13 bits)		SSI	ECN 413/EQN 425	
	250 to 5000	–	\square TTL	ERN 420		
			\square HTL	ERN 430		
			\square TTL	ERN 460		
	1000 to 5000		$\sim 1 V_{PP}$	ERN 480		
	256 to 2048	8192 (13 bits)	–/4096	EnDat H \square HTL SSI 41H \square HTL	EQN 425	Brochure: Rotary Encoders
	512 to 4096			EnDat T \square TTL SSI 41T \square TTL		
	–	α i: 33554432 (25 bits)	4096	Fanuc	ECN 425 F/EQN 437 F	
		33554432 (25 bits)/ 8388608 (23 bits)		Mitsubishi	ECN 425 M/EQN 435 M	
		16777216 (24 bits)		DRIVE-CLiQ	ECN 424 S/EQN 436 S	
	2048	8192 (13 bits)	–/4096	EnDat 2.2/01 with $\sim 1 V_{PP}$	ECN 413/EQN 425	Page 64
	–	33554432 (25 bits)		EnDat 2.2/22	ECN 425¹⁾/EQN 437¹⁾	
	1024 to 5000	–		\square TTL	ERN 421	Product Information document
	2048	Z1 track for sine commutation		$\sim 1 V_{PP}$	ERN 487	

Rotary encoders for mounting on motors

Protection class: up to IP64 (EN 60529)

Series	Main dimensions	Mechanically permissible shaft speed	Natural frequency f_N (typical) of the coupling	Maximum operating temperature	Supply voltage
Rotary encoders with integral bearing and mounted stator coupling					
ECN/EQN/ERN 1000		$\leq 12\,000$ rpm	1500 Hz	95 °C	DC 10 V to 28.8 V
				100 °C	DC 3.6 V to 14 V
					DC 4.75 V to 30 V
					DC 3.6 V to 14 V
				70 °C	DC 10 V to 30 V
DC 5 V ± 0.25 V					
$\leq 6\,000$ rpm	1600 Hz	90 °C	DC 5 V ± 0.5 V		
Rotary encoders with integral bearing and torque support for Siemens motors					
EQN/ERN 400		$\leq 6\,000$ rpm	–	100 °C	DC 3.6 V to 14 V
					DC 10 V to 30 V
					DC 5 V ± 0.5 V
					DC 10 V to 30 V
ERN 401		$\leq 6\,000$ rpm	–	100 °C	DC 5 V ± 0.5 V
					DC 10 V to 30 V

¹⁾ After internal 5/10/20/25-fold interpolation

	Signal periods per revolution	Positions per revolution	Distinguishable revolutions	Interface	Model	Further information
	–	8192 (13 bits)	–/4096	DRIVE-CLiQ	ECN 1023S/EQN 1035S	Brochure: Rotary Encoders
	512			EnDat 2.2/01 with $\sim 1 V_{PP}$	ECN 1013/EQN 1025	
				SSI		
	–	8388608 (23 bits)		EnDat 2.2/22	ECN 1023/EQN 1035	
	100 to 3600	–		\square TTL/ $\sim 1 V_{PP}$	ERN 1020/ERN 1080	
				\square HTLs	ERN 1030	
	5000 to 36000 ¹⁾			\square TTL	ERN 1070	
	500 to 8192	3 block commutation signals		\square TTL	ERN 1023	Page 56
	2048	8192 (13 bits)	4096	EnDat 2.1/01 with $\sim 1 V_{PP}$	EQN 425	Page 68
				SSI		
	1024	–		\square TTL	ERN 420	Page 70
				\square HTL	ERN 430	
	1024			\square TTL	ERN 421	
				\square HTL	ERN 431	

Rotary encoders for mounting on motors

Protection class: up to IP64 (EN 60529)

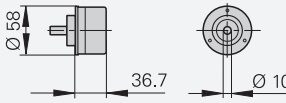
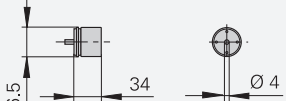
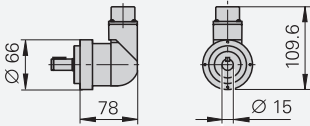
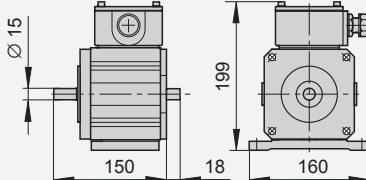











Series	Main dimensions	Mechanically permissible shaft speed	Natural frequency f_N (typical) of the coupling	Maximum operating temperature	Supply voltage
Rotary encoders with integral bearing for separate shaft coupling					
ROC/ROQ/ROD 400 RIC/RIQ	<p>Synchro flange</p>  <p>Clamping flange</p> 	≤ 12000 rpm	–	100 °C	DC 3.6 V to 14 V
					DC 4.75 V to 30 V
					DC 10 V to 30 V
					DC 4.75 V to 30 V
				70 °C	DC 3.6 V to 14 V
					DC 10 V to 28.8 V
					DC 5 V ±0.5 V
					DC 10 V to 30 V
100 °C	DC 5 V ±0.5 V				
	DC 3.6 V to 14 V				
	DC 4.75 V to 30 V				
	DC 3.6 V to 14 V				
ROC/ROQ/ROD 1000		≤ 12000 rpm	–	100 °C	DC 3.6 V to 14 V
					DC 4.75 V to 30 V
					DC 3.6 V to 14 V
				95 °C	DC 10 V to 28.8 V
					100 °C
				70 °C	DC 10 V to 30 V
DC 5 V ±0.25 V					
ROD 600		≤ 12000 rpm	–	80 °C	DC 5 V ±0.5 V
ROD 1900		≤ 4000 rpm	–	70 °C	DC 10 V to 30 V

¹⁾ Also available with functional safety

²⁾ After integrated 5/10-fold interpolation

³⁾ Only clamping flange

DRIVE-CLiQ is a registered trademark of Siemens AG.

	Signal periods per revolution	Positions per revolution	Distinguishable revolutions	Interface	Model	Further information
	512/2048	8192 (13 bits)	-/4096	EnDat 2.2/01 with $\sim 1 V_{PP}$	ROC 413/ROQ 425	Brochure: Rotary Encoders
	–	33554432 (25 bits)		EnDat 2.2/22	ROC 425¹⁾/ROQ 437¹⁾	
	512	8192 (13 bits)		SSI	ROC 413/ROQ 425	
	256 to 2048	8192 (13 bits)	-/4096	EnDat H  HTL SSI 41H  HTL	ROQ 425³⁾	
	512 to 4096			EnDat T  TTL SSI 41T  TTL		
	–	α i: 33554432 (25 bits)	4096	Fanuc	ROC 425 F/ROQ 437 F	
		33554432 (25 bits)/ 8388608 (23 bits)		Mitsubishi	ROC 425 M/ROQ 435 M	
		16777216 (24 bits)		DRIVE-CLiQ	ROC 424 S/EQN 436 S	
	50 to 10000 ²⁾	–	–	 TTL	ROD 426/ROD 420	
	50 to 5000			 HTL	ROD 436/ROD 430	
	50 to 10000 ²⁾			 TTL	ROD 466	
	1000 to 5000			$\sim 1 V_{PP}$	ROD 486/ROD 480	
	512	8192 (13 bits)	-/4096	EnDat 2.2/01 with $\sim 1 V_{PP}$	ROC 1013/ROQ 1025	Brochure: Rotary Encoders
				SSI		
	–	8388608 (23 bits)		EnDat 2.2/22	ROC 1023/ROQ 1035	
				DRIVE-CLiQ	ROC 1023 S/ROQ 1035 S	
	100 to 3600	–		 TTL	ROD 1020	
				$\sim 1 V_{PP}$	ROD 1080	
				 HTLs	ROD 1030	
	5000 to 36000 ²⁾			 TTL	ROD 1070	
	512 to 5000	–		 TTL	ROD 620	
				 HTL	ROD 630	
	600 to 2400	–		 HTL/HTLs	ROD 1930	

Angle encoders for built-in and hollow-shaft motors

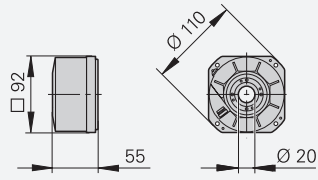
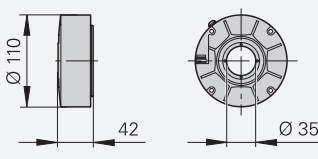
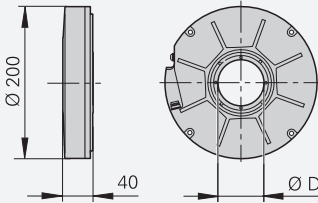
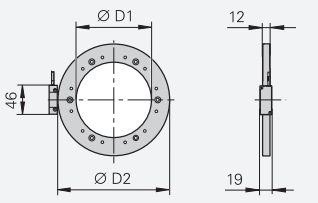
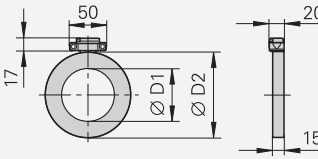
Series	Main dimensions	Diameter	Mechanically permissible shaft speed	Natural frequency f_N (typical) of the coupling	Maximum operating temperature
Angle encoders with integral bearing and integrated stator coupling					
RCN 2000		20 mm	≤ 1500 rpm	1000 Hz	RCN 23xx: 60 °C RCN 25xx: 50 °C
RCN 5000		35 mm	≤ 1500 rpm	1000 Hz	RCN 53xx: 60 °C RCN 55xx: 50 °C
RCN 8000		D: 60 mm and 100 mm	≤ 500 rpm	900 Hz	50 °C
Modular angle encoders with optical scanning					
ECA 4000 Scale drum with centering collar; screwed to shaft on front face		D1: 70 mm to 512 mm D2: 104.3 mm to 560.46 mm	≤ 8500 rpm to ≤ 1500 rpm	–	70 °C
ERA 4x80 Scale drum with centering collar; screwed to shaft on front face		D1: 40 mm to 512 mm D2: 76.5 mm to 560.46 mm	≤ 10000 rpm to ≤ 1500 rpm	–	80 °C
ERA 4282 Scale drum for increased accuracy; screwed to shaft on front face		D1: 40 mm to 270 mm D2: 76.5 mm to 331.31 mm	≤ 10000 rpm to ≤ 2500 rpm	–	80 °C
Modular angle encoders with magnetic scanning					
ERM 2200 Signal period of approx. 200 μ m ERM 2400 Signal period of approx. 400 μ m		D1: 40 mm to 410 mm D2: 75.44 mm to 452.64 mm	≤ 19000 rpm to ≤ 3000 rpm	–	100 °C
ERM 2400 Signal period of approx. 400 μ m		D1: 40 mm to 100 mm D2: 64.37 mm to 128.75 mm	≤ 42000 rpm to ≤ 20000 rpm	–	100 °C
ERM 2900 Signal period of approx. 1000 μ m		D1: 40 mm to 100 mm D2: 58.06 mm to 120.96 mm	≤ 35000 rpm/ ≤ 16000 rpm	–	100 °C

¹⁾ Interfaces for Fanuc and Mitsubishi controls upon request

²⁾ Segment solutions upon request

	Supply voltage	System accuracy	Signal periods per revolution	Positions per revolution	Interface ¹⁾	Model	Further information
	DC 3.6 V to 14 V	±5" ±2.5"	16384	67 108 864 (26 bits) 268 435 456 (28 bits)	EnDat 2.2/02 with \sim 1 V _{PP}	RCN 2380 RCN 2580	Brochure: Angle Encoders <i>With Integral Bearing</i>
		±5" ±2.5"	–	67 108 864 (26 bits) 268 435 456 (28 bits)	EnDat 2.2/22	RCN 2310 ³⁾ RCN 2510 ³⁾	
	DC 3.6 V to 14 V	±5" ±2.5"	16384	67 108 864 (26 bits) 268 435 456 (28 bits)	EnDat 2.2/02 with \sim 1 V _{PP}	RCN 5380 RCN 5580	
		±5" ±2.5"	–	67 108 864 (26 bits) 268 435 456 (28 bits)	EnDat 2.2/22	RCN 5310 ³⁾ RCN 5510 ³⁾	
	DC 3.6 V to 14 V	±2" ±1"	32 768	536 870 912 (29 bits)	EnDat 2.2/02 with \sim 1 V _{PP}	RCN 8380 RCN 8580	
		±2" ±1"	–		EnDat 2.2/22	RCN 8310 ³⁾ RCN 8510 ³⁾	
	DC 3.6 V to 14 V	±3" to ±1.5"	–	–	EnDat 2.2	ECA 4410 ³⁾	Product Information document: ECA 4000
					Fanuc	ECA 4490 F	
					Mitsubishi	ECA 4490 M	
	DC 5 V ±0.5 V	±5" to ±2"	12 000 to 52 000	–	\sim 1 V _{PP}	ERA 4280 C	Brochure: Modular Angle Encoders <i>With Optical Scanning</i>
			6 000 to 44 000			ERA 4480 C	
			3 000 to 13 000			ERA 4880 C	
	DC 5 V ±0.5 V	±4" to ±1.7"	12 000 to 52 000	–	\sim 1 V _{PP}	ERA 4282 C	
	DC 5 V ±0.5 V	–	600 to 3600	–	\square TTL	ERM 2420	Brochure: Modular Angle Encoders <i>With Magnetic Scanning</i>
					\sim 1 V _{PP}	ERM 2280 ERM 2480	
	DC 5 V ±0.5 V	–	512 to 1024	–	\sim 1 V _{PP}	ERM 2484	
			256/400	–		ERM 2984	

³⁾ Also available with functional safety

Exposed linear encoders for linear motors

Series	Main dimensions	Traversing speed	Acceleration in measuring direction	Accuracy grade
LIP 6000		≤ 240 m/min	≤ 500 m/s ²	Down to ±1 μm ¹⁾
LIF 400		≤ 240 m/min	≤ 400 m/s ²	±1 μm ¹⁾
LIC 2100 Absolute linear encoder		≤ 600 m/min	≤ 500 m/s ²	±15 μm
LIC 4100²⁾ Absolute linear encoder		≤ 600 m/min	≤ 500 m/s ²	±5 μm
				±5 μm ³⁾
				±3 μm or ±15 μm
LIDA 400		≤ 480 m/min	≤ 500 m/s ²	±5 μm
				±5 μm ¹⁾
LIDA 200		≤ 600 m/min	≤ 200 m/s ²	±15 μm

1) With Zerodur glass ceramic up to a measuring length of 1020 mm

2) Also available with Fanuc, Mitsubishi, and Panasonic interfaces

3) After linear error compensation

4) Also available with functional safety

	Measuring lengths	Supply voltage	Signal period	Cutoff frequency -3 dB	Switching output	Interface	Model	Further information
	20 mm to 3040 mm	DC 5 V ±0.5 V	4 μm	≥ 1 MHz	Homing track Limit switch	~ 1 V _{PP}	LIP 6081	Brochure: Exposed Linear Encoders
						□TTL	LIP 6071	
	70 mm to 1020 mm	DC 5 V ±0.25 V	4 μm	≥ 1 MHz	Homing track Limit switch	~ 1 V _{PP}	LIF 481	
						□TTL	LIF 471	
	120 mm to 3020 mm	DC 3.6 V to 14 V	–	–	–	EnDat 2.2/22 Resolution: 0.05 μm	LIC 2107	
	140 mm to 27 040 mm	DC 3.6 V to 14 V	–	–	–	EnDat 2.2/22 Resolution: 0.001 μm	LIC 4115	
	140 mm to 6040 mm						LIC 4117	
	70 mm to 1020 mm	DC 3.6 V to 14 V	–	–	–	EnDat 2.2	LIC 4119⁴⁾	
	140 mm to 30 040 mm	DC 5 V ±0.25 V	20 μm	≥ 400 kHz	Limit switch	~ 1 V _{PP}	LIDA 485	
						□TTL	LIDA 475	
	240 mm to 6040 mm					~ 1 V _{PP}	LIDA 487	
						□TTL	LIDA 477	
	Up to 10 000 mm	DC 5 V ±0.25 V	200 μm	≥ 50 kHz	–	~ 1 V _{PP}	LIDA 287	
						□TTL	LIDA 277	

Sealed linear encoders for linear motors

Protection class: IP53 to IP64¹⁾ (EN 60529)

Series	Main dimensions	Traversing speed	Acceleration in direction of measurement	Measuring lengths
Linear encoders with slimline scale housing				
LF		≤ 60 m/min	≤ 100 m/s ²	50 mm to 1220 mm
LC Absolute linear encoder		≤ 180 m/min	≤ 100 m/s ²	70 mm to 2040 mm ³⁾
Linear encoders with full-size scale housing				
LF		≤ 60 m/min	≤ 100 m/s ²	140 mm to 3040 mm
LC Absolute linear encoder		≤ 180 m/min	≤ 100 m/s ²	140 mm to 4240 mm
				140 mm to 3040 mm
LC Absolute linear encoder		≤ 120 m/min (180 m/min upon request)	≤ 100 m/s ²	140 mm to 4240 mm
				140 mm to 3040 mm
LC Absolute linear encoder		≤ 120 m/min (180 m/min upon request)	≤ 100 m/s ²	440 mm to 28040 mm
				440 mm to 30040 mm (up to 72040 mm upon request)
LB		≤ 120 m/min (180 m/min upon request)	≤ 60 m/s ²	440 mm to 30040 mm (up to 72040 mm upon request)

1) After mounting in accordance with mounting instructions

2) Interfaces for Siemens, Fanuc, and Mitsubishi controls available upon request

3) At or above a measuring length of 1340 mm: only with mounting spar or clamping elements

4) Also available with functional safety

	Accuracy grade	Supply voltage	Signal period	Cutoff frequency -3 dB	Resolution	Interface ²⁾	Model	Further information
	±5 µm	DC 5 V ±0.25 V	4 µm	≥ 250 kHz	–	~ 1 V _{PP}	LF 485	Brochure: Linear Encoders For Numerically Controlled Machine Tools
	±5 µm	DC 3.6 V to 14 V	–	–	Down to 0.01 µm	EnDat 2.2/22	LC 415⁴⁾	
	±3 µm				Down to 0.001 µm			
	±5 µm		20 µm	≥ 150 kHz	Down to 0.01 µm	EnDat 2.2/02	LC 485	
	±3 µm				Down to 0.05 µm			
	±2 µm; ±3 µm	DC 5 V ±0.25 V	4 µm	≥ 250 kHz	–	~ 1 V _{PP}	LF 185	Brochure: Linear Encoders For Numerically Controlled Machine Tools
	±5 µm	DC 3.6 V to 14 V	–	–	Down to 0.01 µm	EnDat 2.2/22	LC 115⁴⁾	
	±3 µm				Down to 0.001 µm			
	±5 µm		20 µm	≥ 150 kHz	Down to 0.01 µm	EnDat 2.2/02	LC 185	
	±3 µm				Down to 0.05 µm			
	±5 µm	DC 3.6 V to 14 V	–	–	Down to 0.01 µm	EnDat 2.2/22	LC 211	
			40 µm	≥ 250 kHz		EnDat 2.2/02 with ~ 1 V _{PP}	LC 281	
	Down to ±5 µm	DC 5 V ±0.25 V	40 µm	≥ 250 kHz	–	~ 1 V _{PP}	LB 382	

Rotary encoders and angle encoders for DC and three-phase AC motors

General information

Speed stability

In order to obtain **good motor speed stability**, the encoder must provide a **high number of measuring steps per revolution**. For this reason, the HEIDENHAIN product portfolio includes encoders that output a sufficient number of measuring steps per revolution for the required speed stability.

HEIDENHAIN rotary encoders and angle encoders with an integral bearing and stator coupling exhibit particularly advantageous behavior: shaft misalignment within a certain tolerance range does not induce position errors or impaired speed stability (see *Specifications*).

Position errors within one signal period adversely affect the positioning accuracy and speed stability of the motor. At low feed rates, the motor mimics the position error within one signal period.

Transmission of measuring signals

For good dynamic performance with digital speed control, the cycle time of the speed controller should not exceed approximately 125 μs . In addition, the actual values for the position controller and speed controller must be available to the controlling system with the least possible delay.

High clock frequencies are needed to fulfill such demanding time requirements on position-value transmission from the encoder to the controlling system with serial data transmission (see also the *Interfaces of HEIDENHAIN Encoders* brochure). This is why HEIDENHAIN encoders for electric motors output the position values over the fast, **purely serial EnDat 2.2 interface** or transmit additional **incremental signals** that are available to the subsequent electronics virtually without delay for speed or position control.

The encoders primarily used for **standard motors** (permanent magnet DC motors with additional commutation signals) are the particularly robust **ECI/EQI** absolute encoders without an integral bearing, or rotary encoders with **TTL-** or **HTL-compatible output signals**.

For **digital speed control** on machines with **high dynamic-performance requirements**, a large number of measuring steps are required—usually more than 500 000 per revolution. For applications with standard motors, approximately 60 000 measuring steps per revolution are sufficient (similar to resolvers).

HEIDENHAIN encoders for motors with digital position and speed control are therefore equipped with the **purely serial EnDat22 interface**, or they output additional **sinusoidal incremental signals** at 1 V_{PP} signal levels (EnDat01).

The high internal resolution of the **EnDat22** encoders permits resolutions of up to 19 bits (524 288 measuring steps) in inductive systems and at least 23 bits (approx. 8 million measuring steps) in photoelectric encoders.

Thanks to their high signal quality, the sinusoidal incremental signals of the **EnDat01** encoders can be highly subdivided in the subsequent electronics (see Figure 1). Even at shaft speeds of 12 000 rpm, the signal arrives at the input circuit of the controlling system with a frequency of only approx. 400 kHz (see Figure 2). Cable lengths of up to 150 m are possible with 1 V_{PP} incremental signals (see also *1 V_{PP} incremental signals*).

Figure 1:

Signal periods per revolution and the resulting number of measuring steps per revolution as a function of the subdivision factor

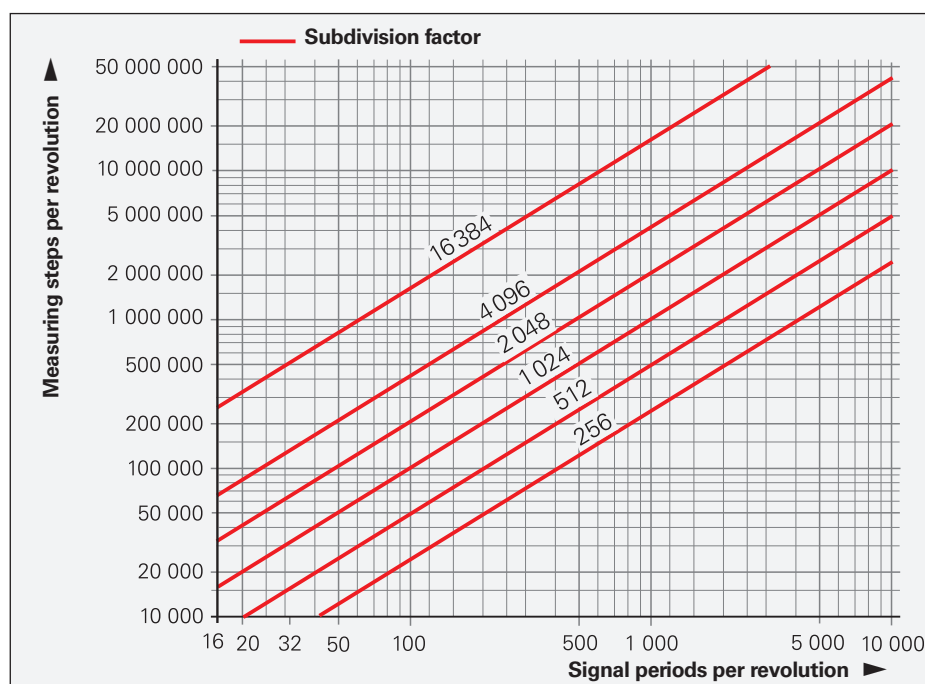

HEIDENHAIN absolute encoders for “digital” motors deliver additional sinusoidal incremental signals with the same characteristics as those described above. For the **serial transmission** of coded position values and other data for **automatic self-configuration, monitoring, and diagnostics**, the absolute encoders from HEIDENHAIN are equipped with the EnDat (**Encoder Data**) interface. This makes it possible to use the same subsequent electronics and cabling technology for all HEIDENHAIN encoders.

For automatic configuration, important encoder specifications can be read from the memory of the EnDat encoder, and motor-specific parameters can be saved in the encoder’s OEM memory area. The usable size of the OEM memory for the rotary encoders listed in the current brochures is at least 1.4 KB ($\hat{=}$ 704 EnDat words).

Most absolute encoders internally subdivide the sinusoidal scanning signals by a factor of 4096 or greater. When these systems are operated with sufficiently **fast transmission** of the absolute position values (e.g., at a clock frequency of 2 MHz with EnDat 2.1 or 16 MHz with **EnDat 2.2**), **incremental signal evaluation can be eliminated altogether**.

The benefits of this data transmission technology are **higher noise immunity** along the transmission path and **less expensive connectors and cables**. Rotary encoders equipped with the EnDat 2.2 interface are also able to **evaluate** an external **temperature sensor** (e.g., located in the motor winding). The digitalized temperature values are transmitted as part of the EnDat 2.2 protocol without an additional line.

Bandwidth

The attainable gain levels for the position and speed control loops, and therefore the bandwidth of the motor with regard to command and disturbance behavior, may be limited by the rigidity of the coupling between the motor shaft and the encoder shaft, as well as by the natural frequency of the stator coupling. HEIDENHAIN therefore offers rotary and angle encoders for high-rigidity shaft couplings. The stator couplings mounted on the encoder exhibit **high natural frequencies f_N** . With modular and inductive rotary encoders, the stator and rotor are firmly screwed to the motor housing and the shaft (see also *Mechanical design types and mounting*). This mechanical design therefore permits optimal coupling rigidity.

Motor currents

Motors may exhibit impermissible current flowing from the rotor to the stator. This can cause the encoder bearing to overheat, thereby shortening its service life. HEIDENHAIN thus recommends the use of encoders without an integral bearing or encoders with an electrically isolated bearing (hybrid bearing). For more information, please contact HEIDENHAIN.

Fault exclusion for mechanical coupling

HEIDENHAIN encoders designed for functional safety can be mounted in such a way that the rotor or stator fastening does not accidentally loosen.

Size

The higher a motor’s permissible operating temperature is, the smaller the motor can be made for a given torque. Since the temperature of the motor also affects the temperature of the encoder, HEIDENHAIN offers encoders for **permissible operating temperatures of up to 120 °C**. These encoders make it possible to implement smaller motors.

Power dissipation and acoustic noise

While the motor is running, encoder position errors within one signal period affect the motor’s power dissipation as well as the heat generation and acoustic noise that go along with it. For this reason, rotary encoders with high signal quality (better than $\pm 1\%$ of the signal period) are preferred (see also *Measuring accuracy*).

Bit error rate

For rotary encoders with a purely serial interface for installation within motors, HEIDENHAIN recommends conducting a type test for the bit error rate.

The use of functionally safe encoders without closed metal housings and/or with cable assemblies that do not comply with the electrical connection directives (see *General electrical information*) always requires the bit error rate to be measured in a type test under application conditions.

Figure 2: Shaft speed and resulting output frequency as a function of the number of signal periods per revolution

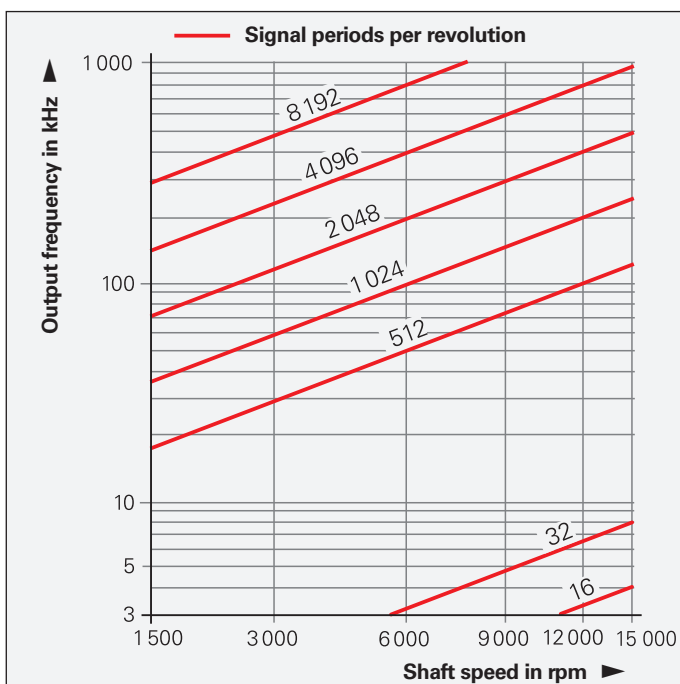

HMC 6

Single-cable solution for servomotors

Servomotors normally require two separate cables:

- One encoder cable for the motor encoder
- One power cable for the motor supply

With the **HMC 6** (Hybrid Motor Cable), HEIDENHAIN has integrated the encoder cable into the power cable. Thus, only **a single cable** is now needed between the motor and the electrical cabinet.

The HMC 6 single-cable solution was specifically designed for the HEIDENHAIN **EnDat22** interface with its purely serial transmission over cable lengths of up to 100 m. However, all other encoders equipped with a purely serial RS-485 interface (e.g., SSI) can be connected as well. A wide range of encoders can therefore be used without the need for introducing a new interface.

The HMC 6 solution combines the wires for the encoder, motor, and brake into a single cable, which is connected to the motor via a special connector. For connection to the drive, the cable is split into power connections, brake connections, and an encoder connector, thereby permitting the continued use of already existing control-side components.

When the components are correctly assembled, the connecting elements attain an IP67 rating. The connector includes an integrated quick-release lock and vibration protection to prevent loosening of the coupling joint.

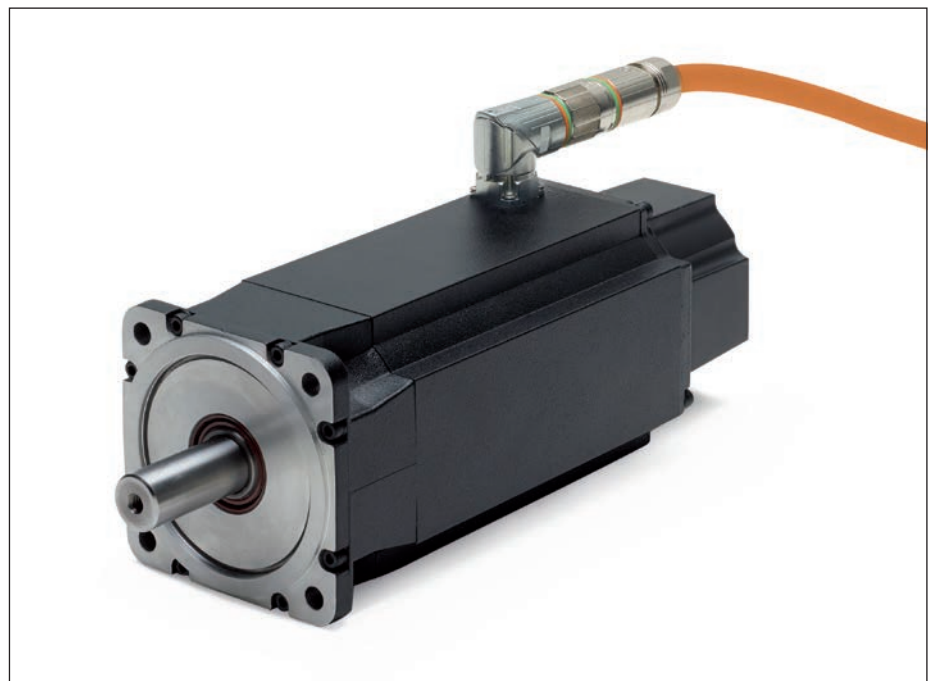
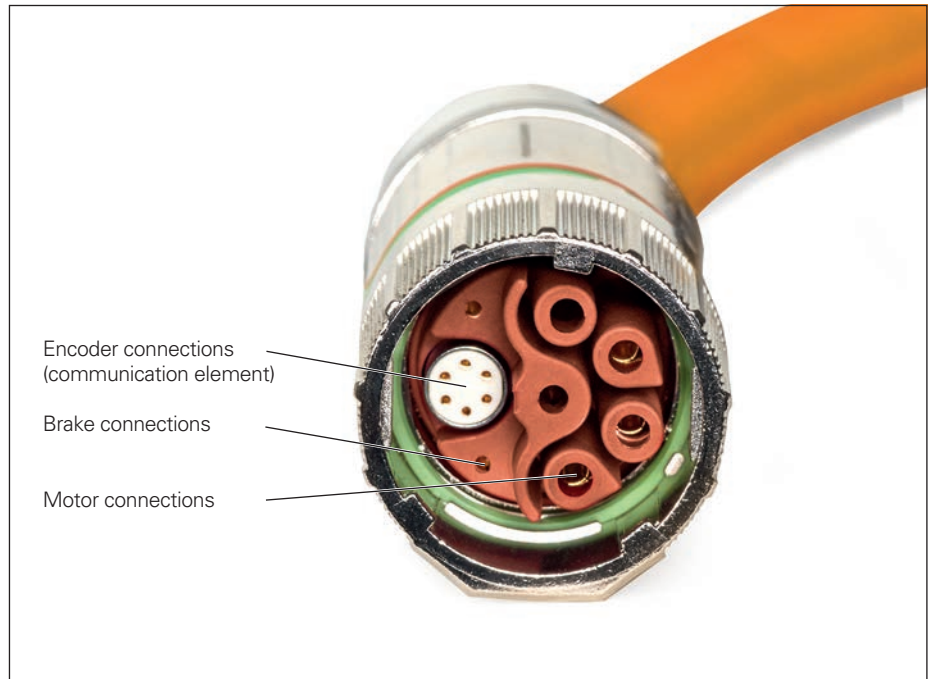

Advantages

The HMC 6 single-cable solution offers a series of cost and quality benefits, both for the motor maker and the machine manufacturer:

- Continued use of existing interfaces
- Realization of smaller drag chains
- Significant improvement in drag-chain suitability thanks to fewer cables
- Wide range of available encoders for HMC 6 transmission
- Eliminated separate assignment of power cables and encoder cables in the machine
- Reduced mechanical requirements (flange socket on the motor, cable ducts in the machine housing)
- Reduced logistical cost and effort for cables and connectors
- Easier and faster installation
- Reduced documentation
- Fewer required servicing components
- Smaller motor profile with attached cable, enabling easier integration into the machine housing
- HEIDENHAIN-tested combination of power and encoder cable

The universal design of the HMC 6 gives motor makers and machine manufacturers the greatest possible flexibility, allowing them to deploy standard components on both the motor and the control.

A particular advantage of the HMC 6 single-cable solution is its suitability for **all HEIDENHAIN encoders with the EnDat22 interface** or with purely serial data transmission without battery buffering in accordance with RS-485. This includes motor encoders for servomotors in various sizes, as well as linear and angle encoders used in direct drive motors. Of course, encoders designed for **functional safety** up to SIL 3 are also included.

But effort is minimal on the control end of things as well because already deployed drives or controller units can continue to be used. The HMC 6 cable has been designed for easy assembly of the matching connecting elements. Importantly, this does not impair its noise immunity.



Components

Getting a motor ready for the single-cable solution requires only a handful of components.

Connecting element on the motor

The motor housing is equipped with a special angle flange socket in which the wires for the encoder, the motor power supply, and the brake come together.

Crimping tools for the power wires

The crimp contacts for the power and brake wires are assembled with the usual tools.

Output cables inside the motor housing

The rotary encoder is connected by means of the output cables inside the motor housing: your pre-assembled communication element is simply plugged into the angle flange socket.

Cable with hybrid connector

The HMC 6 connecting cable contains the wires for the encoder, power supply, and brake, and is assembled with a hybrid connector on one end.

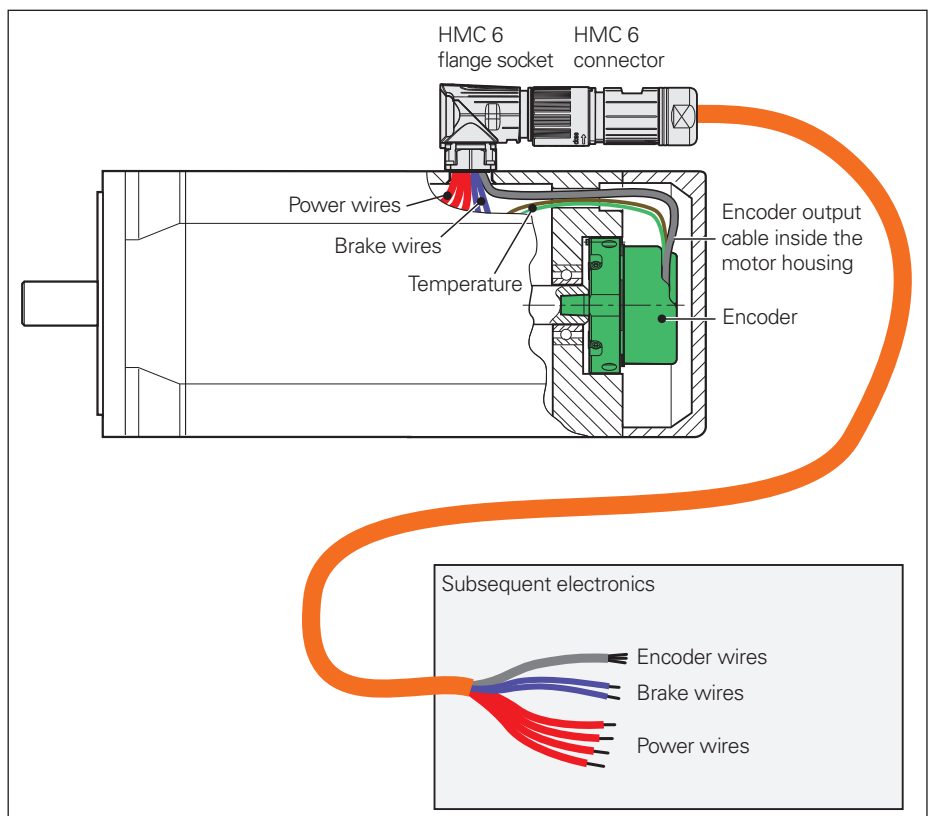

Further information:

For more information about HMC 6, refer to the *HMC 6* Product Information document.

Safety-related position measuring systems

Under the “functional safety” designation, HEIDENHAIN offers encoders that can be used in safety-related applications. These encoders operate as single-encoder systems with purely serial data transmission via EnDat 2.2 or DRIVE-CLiQ. Reliable transmission of the position is based on two independently generated absolute position values and on error bits provided to the safe control.

Basic principle

HEIDENHAIN measuring systems for safety-related applications are tested for compliance with EN ISO 13849-1 (successor to EN 954-1) as well as EN 61508 and EN 61800-5-2. In these standards, the assessment of safety-related systems is based on, among other things, the failure probabilities of integrated components and subsystems. This modular approach makes it easier for the manufacturers of safety-related systems to implement their complete systems, allowing them to build upon subsystems that have already been qualified. Safety-related position measuring systems with purely serial data transmission via EnDat 2.2 or DRIVE-CLiQ are accommodative to this approach. In a safe drive system, the safety-related position measuring system is such a subsystem. A **safety-related position measuring system** (e.g., with EnDat 2.2) consists of the following components:

- Encoder with EnDat 2.2 transmission component
- Transmission line with EnDat 2.2 communication and HEIDENHAIN cable
- EnDat 2.2 receiver component with monitoring function (EnDat master)

In practice, the **complete safe drive system** (e.g., with EnDat 2.2) consists of the following:

- Safety-related position measuring system
- Safety-related control (including EnDat Master with monitoring functions)
- Power stage with motor power cable and motor
- Mechanical connection between the encoder and motor (e.g., rotor/stator connection)

Area of application

Safety-related position measuring systems from HEIDENHAIN are designed such that they can be used as single-encoder systems in applications with control category SIL 2 (according to EN 61508), PL d, Category 3 (according to EN ISO 13849).

Through additional measures taken in the control, certain encoders can be used in applications up to SIL 3, PL e, Category 4. The suitability of these encoders is indicated accordingly in the documentation (brochures / Product Information documents).

The functions of the safety-related position measuring system can be used for the following safety functions in the complete system (also see EN 61800-5-2):

SS1	Safe Stop 1
SS2	Safe Stop 2
SOS	Safe Operating Stop
SLA	Safely Limited Acceleration
SAR	Safe Acceleration Range
SLS	Safely Limited Speed
SSR	Safe Speed Range
SLP	Safely Limited Position
SLI	Safely Limited Increment
SDI	Safe Direction
SSM	Safe Speed Monitor

Safety functions according to EN 61800-5-2

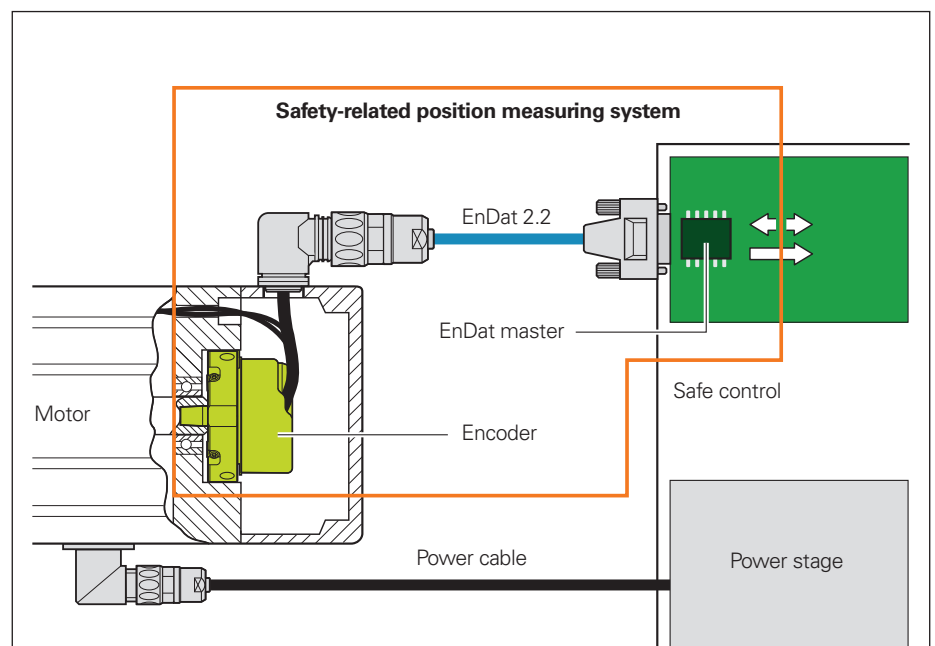

Complete safe drive system with EnDat 2.2

Manner of functioning

The safety design of the position measuring system is based on two mutually independent position values generated in the encoder, and on additional error bits. With EnDat 2.2, for example, these error bits are transmitted to the EnDat master via the EnDat 2.2 protocol. The EnDat master performs various monitoring functions that help detect errors in the encoder and in the transmission. For example, a comparison of the two position values is performed. The EnDat master then makes the data available to the safe control. The control monitors the functionality of the safety-related position measuring system through periodically triggered tests.

The architecture of the EnDat 2.2 protocol enables the processing of all safety-related information or control mechanisms during unimpaired normal operation. This is due to the fact that the safety-related information is contained in the additional data.

According to EN 61508, the architecture of the position measuring system is regarded as a single-channel tested system.

Integration of the position measuring system: documentation

The proper use of a position measuring system places demands on the control, the machine designer, the installation technician, servicing personnel, etc. The documentation for the position measuring systems provides the needed information.

For implementing a position measuring system in a safety-related application, a suitable control is required. The control performs the essential tasks of carrying out communication with the encoder and performing the safe evaluation of the encoder data.

The requirements for integrating the EnDat master with monitoring functions into the safe control are described in HEIDENHAIN Document 533095. Among other things, this document contains requirements for the evaluation and further processing of the position values and error bits, as well as requirements for the electrical connection and for cyclic tests of the position measurement system.

Supplementing this information, Document 1000344 describes measures that enable the use of suitable encoders in applications up to SIL 3, PL e, Category 4.

Machine and equipment manufacturers do not need to attend to these details themselves. This functionality must be provided by the control. Product information sheets, brochures, and mounting instructions provide information to aid in the selection of a suitable encoder. The **Product Information document** and **brochure** contain general information on the functionality and deployment of the encoders, and on specifications and permissible ambient conditions. The **mounting instructions** provide detailed information about installing the encoders.

The architecture of the safety system and the diagnostic capabilities of the control may call for further requirements. **Thus, the operating instructions for the control must explicitly state whether fault exclusion is required for the loosening of the mechanical connection between the encoder and the motor.**

The installation technician and the servicing staff, for example, must be notified by the machine designer regarding any such resulting requirements.

Fault exclusion for the loosening of the mechanical connection

Many safety designs require a safe mechanical connection of the encoder regardless of the interface. The standard for electric motors, EN 61800-5-2, defines the loss or loosening of the mechanical connection between the encoder and motor as a fault that requires consideration. Because the control may not be able to detect such errors, fault exclusion is required in many cases.

Standard encoders

In addition to those encoders explicitly qualified for safety applications, standard encoders (e.g., with 1 V_{PP} signals) can also be used in safe applications. In such cases, the characteristics of the encoders must be matched to the requirements of the respective control. To this end, HEIDENHAIN is able to provide additional information about the individual encoders (failure rate, fault model as per EN 61800-5-2).

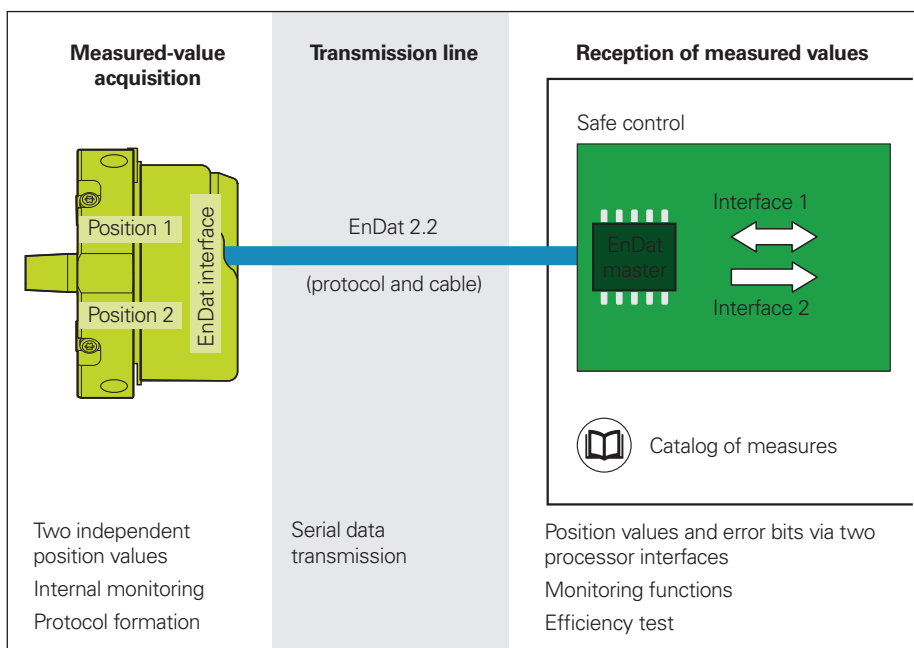

Safety-related position measuring system with EnDat 2.2



Further information:

For more information about functional safety, please refer to the *Safety-Related Position Measuring Systems* and *Safety-Related Control Technology* Technical Information documents, as well as the Product Information documents for encoders with functional safety and the Customer Information documents on fault exclusion.

Measuring principles

Measuring standard

HEIDENHAIN encoders with optical scanning incorporate measuring standards consisting of periodic structures known as graduations. These graduations are applied to a substrate of glass or steel. For encoders with large diameters, steel tape is used as the substrate.

HEIDENHAIN manufactures its precision graduations in specially developed, photolithographic processes:

- AURODUR: matte-etched lines on a gold-plated steel tape; typical grating period: 40 μm
- METALLUR: contamination-tolerant graduation consisting of metal lines on gold; typical grating period: 20 μm
- DIADUR: extremely robust chromium lines on glass (typical grating period: 20 μm), or three-dimensional chromium structures (typical grating period: 8 μm) on glass
- SUPRADUR phase grating: optically three-dimensional, planar structure; particularly tolerant to contamination; typical grating period: 8 μm and finer
- OPTODUR phase grating: optically three-dimensional, planar structure with particularly high reflectance; typical graduation period: 2 μm and finer

For magnetic encoders, a substrate made of magnetizable steel alloy is used. Within it, a graduation consisting of north and south poles is created with a grating period of 400 μm . Due to the short range of electromagnetic interactions and the resulting narrowness of the scanning gap, finer magnetic graduations are not practical.

Encoders that use the **inductive scanning principle** employ metal graduations or copper/nickel-based graduations. These graduation structures are applied to a printed-circuit carrier material.

In the **absolute measuring method**, the position value is available immediately upon encoder switch-on and can be requested by the subsequent electronics at any time. Jogging the axes to determine the reference position is therefore no longer needed. This absolute position information is ascertained **from the graduation of the graduated disk**, which contains a code structure or consists of multiple parallel graduation tracks.

A separate incremental track, or the track with the finest grating period, is interpolated for the position value and is simultaneously used to generate an optional incremental signal.

Singleturn rotary encoders repeat the absolute position information with each revolution. **Multiturn encoders** can additionally distinguish between individual revolutions.



Graduated disks of absolute rotary encoders

In the **incremental measuring method**, the graduation consists of a periodic grating structure. Position information is obtained **through the counting** of individual increments (measuring steps) starting from a freely settable point of origin. Since position ascertainment requires an absolute reference, the graduated disks have an additional track containing a **reference mark**.

The absolute position established by the reference mark is assigned to exactly one measuring step.

Thus, before an absolute reference can be established, or before the most recently selected reference point can be refound, this reference mark must first be traversed.



Graduated disks of incremental rotary encoders

Scanning methods

Photoelectric scanning

Most HEIDENHAIN encoders utilize the photoelectric scanning principle. Photoelectric scanning is performed contact-free and thus does not induce wear. This method detects even extremely fine graduation lines down to a width of only a few micrometers and generates output signals with very small signal periods.

The ERN/ECN/EQN/ERO and ROD/RCN/RQN rotary encoders are designed in accordance with the imaging scanning principle.

Put simply, the imaging scanning principle uses projected-light signal generation: two gratings with equal or similar grating periods—the graduated disk and the scanning reticle—are moved relative to each other. The carrier material of the scanning reticle is transparent, whereas the graduation on the measuring standard may be applied to a transparent or reflective material.

When parallel light passes through a grating structure, light and dark fields are projected at a certain interval. At this location there is an index grating with the same or similar grating period. When the two graduations move relative to each other, the incident light is modulated: if the gaps are aligned, light passes through. If the lines of one grating coincide with the gaps of the other, no light passes through. Photocells or a structured photosensor convert these fluctuations in light into nearly sinusoidal electrical signals. In encoders that use the imaging scanning principle, workable mounting tolerances are attainable starting at a minimum grating period of 10 µm.

Other scanning principles

Some encoders operate in accordance with other scanning methods. As their measuring standard, ERM encoders use a permanently magnetized MAGNODUR graduation that is scanned with magneto-resistive sensors.

ECI/EQI/EBI rotary encoders operate according to the inductive measuring principle. In this case, moving graduation structures modulate the amplitude and phase of a high-frequency signal. By means of circumferential scanning, the position value is always generated based on the signals from the receiver coils that are evenly distributed along the circumference. This permits wide mounting tolerances at high resolution.

The ECN and EQN absolute rotary encoders with optimized scanning contain a single, large-surface, finely structured photosensor rather than a group of individual photocells. The width of the photosensor's structures is identical to that of the measuring standard's grating structure. As a result, the scanning reticle with the index grating can be eliminated.

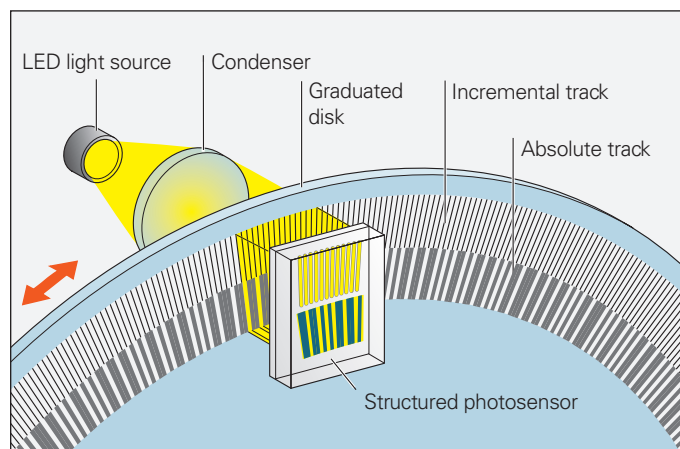

Photoelectric scanning according to the imaging scanning principle

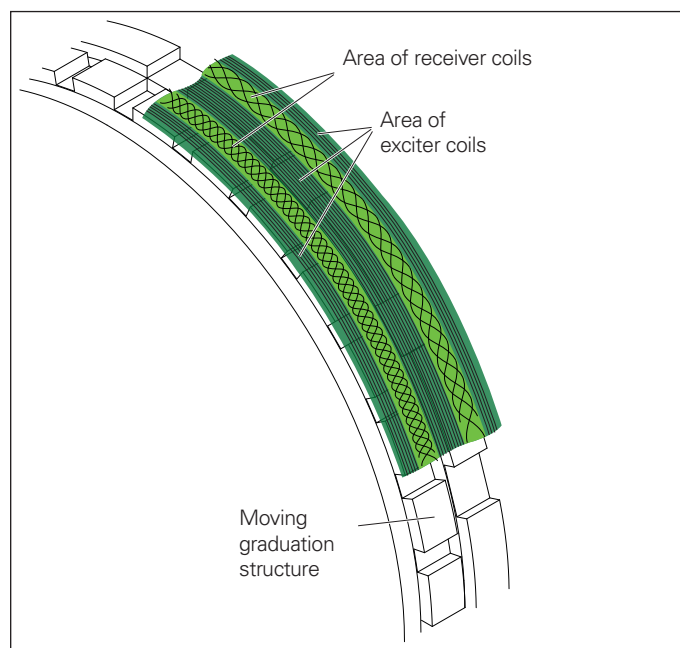

Inductive scanning

Electronic commutation with position encoders

Commutation with permanent-magnet three-phase AC motors

Electronic commutation for a permanent-magnet three-phase AC motor requires the position of the rotor as an absolute value prior to motor start-up. HEIDENHAIN rotary encoders come with different types of rotor position recognition:

- **Absolute rotary encoders** in singleturn and multiturn versions provide the absolute position information immediately after switch-on, allowing the exact position of the rotor to be derived for electronic commutation.
- Along with delivering incremental signals, **incremental rotary encoders with a Z1 track**—provide one sine and one cosine signal (C and D) for each revolution of the motor shaft. For sine commutation, rotary encoders with a Z1 track simply require a subdivision unit and a signal multiplexer in order to obtain the absolute rotor position down to an accuracy of $\pm 5^\circ$ from the Z1 track and to obtain the position information for speed and position control from the incremental track (see also *Interfaces: Commutation signals*).
- **Incremental rotary encoders with block commutation tracks** also output three commutation signals U, V, and W, which are used to directly drive the power electronics. These rotary encoders are available with various commutation tracks. Typical versions have three signal periods (120° mech.) or four signal periods (90° mech.) per commutation signal and revolution. Irrespective of this, the incremental square-wave signals are used for position and speed control (see also *Interfaces: Commutation signals*).

Commutation of synchronous linear motors

Like absolute rotary and angular encoders, the LIC and LC absolute linear encoder series provide the exact position of the motor's moving component immediately upon switch-on. Maximum holding load is thereby possible even at standstill.

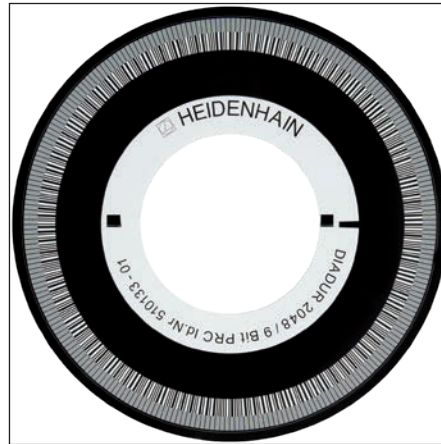

Graduated disk with serial code track and incremental track



Graduated disk with Z1 track

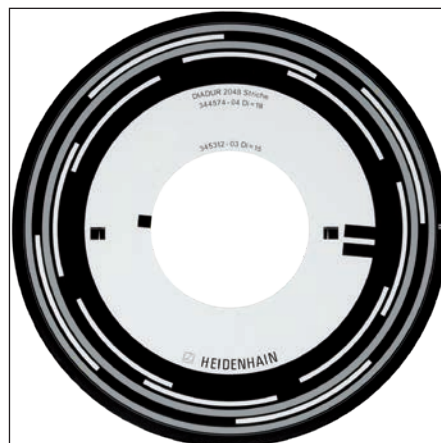

Graduated disk with block commutation tracks



Further information:

Please note the switch-on behavior of the encoders (see the *Interfaces of HEIDENHAIN Encoders* brochure).

Measuring accuracy

The variables influencing the accuracy of **linear encoders** are listed in the *Linear Encoders For Numerically Controlled Machine Tools* and *Exposed Linear Encoders* brochures.

The **angular measurement accuracy** is primarily determined by the following factors:

- Quality of the graduation
- Scanning quality
- Quality of the signal processing electronics
- Eccentricity of the graduation relative to the bearing
- Error of the bearing
- Coupling with the drive shaft
- Elasticity of the stator coupling (ERN, ECN, EQN) or shaft coupling (ROD, ROC, ROQ)

These factors can be divided into encoder-specific errors and application-dependent factors. For assessment of the attainable **overall accuracy**, all of these individual factors must be taken into account.

Encoder-specific error

In the specifications for rotary encoders, the encoder-specific error is stated as the **system accuracy**.

The extreme values of the total error for any given position relative to their mean lie within the system accuracy of $\pm a$.

System accuracy encompasses the position error within a single revolution as well as the position error within one signal period and, for rotary encoders with a stator coupling, the error of the shaft coupling.

Position error within one signal period

The position error within one signal period is considered separately, since it has an effect even in very small angular movements and in repeated measurements. It particularly causes speed ripples in the speed control loop.

The position error within one signal period $\pm u$ arises from the scanning quality and, in the case of encoders with integrated pulse-shaping or counter electronics, from the quality of the signal-processing electronics. In the case of encoders with sinusoidal output signals, however, the error from the signal processing electronics is dictated by the subsequent electronics.

The following individual factors influence the result:

- Fineness of the signal period
- Homogeneity and period definition of the graduation
- Quality of scanning filter structures
- Characteristics of the sensors
- Stability and dynamic performance of further analog signal processing

These errors are taken into account in the information about position error within one signal period. For rotary encoders with an integral bearing and sinusoidal output signals, these errors are less than $\pm 1\%$ of the signal period, and less than $\pm 3\%$ for encoders with square-wave output signals. These signals are suitable for up to 100-fold PLL subdivision.

Due to the higher reproducibility of a position, much smaller measuring steps are still practical.

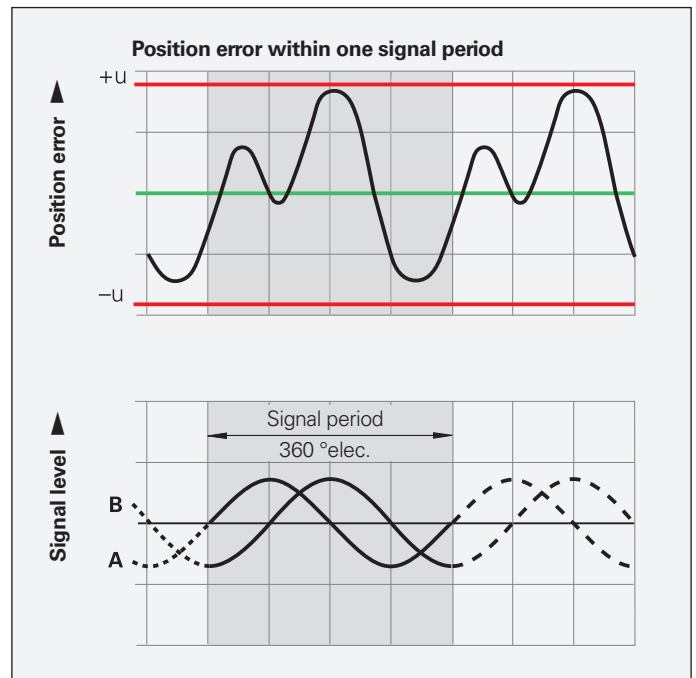
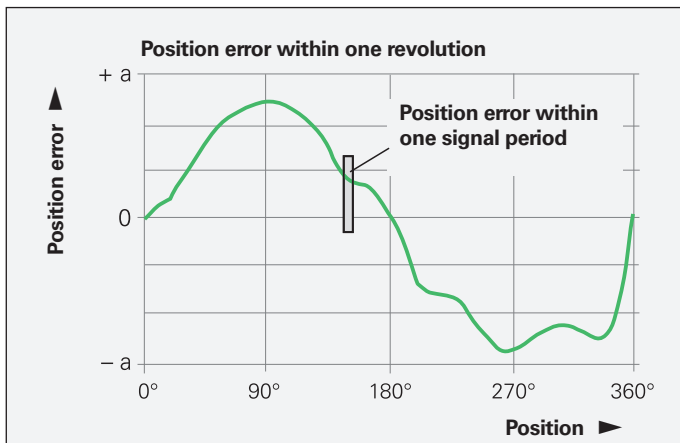

Application-dependent errors

For **rotary encoders with an integral bearing**, the specified system accuracy already takes the error of the bearing into account. In the case of angle encoders with a separate **shaft coupling** (ROD, ROC, ROQ), the angular error of the coupling must be considered as well (see *Mechanical design types and mounting*). For angle encoders with a **stator coupling** (ERN, ECN, EQN), the system accuracy already takes the error of the shaft coupling into account.

In contrast, for **encoders without an integral bearing**, the mounting quality and adjustment of the scanning head have a decisive influence on the attainable overall accuracy. Of particular importance are both the mounting eccentricity of the graduation and the radial runout of the measured shaft. Evaluation of the **overall accuracy** of these encoders requires that their application-dependent errors be individually measured and taken into account.

Rotary encoders with photoelectric scanning

In addition to the system accuracy, the mounting quality and adjustment of the scanning head also have a significant effect on the attainable overall accuracy of rotary encoders without an integral bearing but with photoelectric scanning. Of particular importance are the mounting eccentricity of the graduation and the radial runout of the measured shaft.

Example

An ERO 1420 rotary encoder with a mean graduation diameter of 24.85 mm: A radial runout of the measured shaft of 0.02 mm results in a position error of ± 330 arc seconds within one revolution.

To evaluate the **accuracy of modular rotary encoders without an integral bearing** (ERO), the significant errors must be considered individually.

1. Directional errors of the graduation

ERO: The extreme values of the directional errors relative to their mean are listed in the *Specifications* as the accuracy of the graduation. The system accuracy consists of the graduation accuracy and position error within one signal period.

2. Errors due to eccentricity of the graduation relative to the bearing

During mounting of the disk/hub assembly, it is to be expected that the bearing will exhibit radial runout or eccentricity errors. When centering via the centering collar of the hub, bear in mind that HEIDENHAIN guarantees an eccentricity of the graduation relative to the centering collar of less than $5 \mu\text{m}$ for the encoders listed in this brochure. With modular encoders, this stated accuracy presupposes a diameter error of zero between the motor shaft and the "master shaft."

In the worst-case scenario, if the centering collar is centered relative to the bearing, then the two eccentricity vectors may be cumulative.

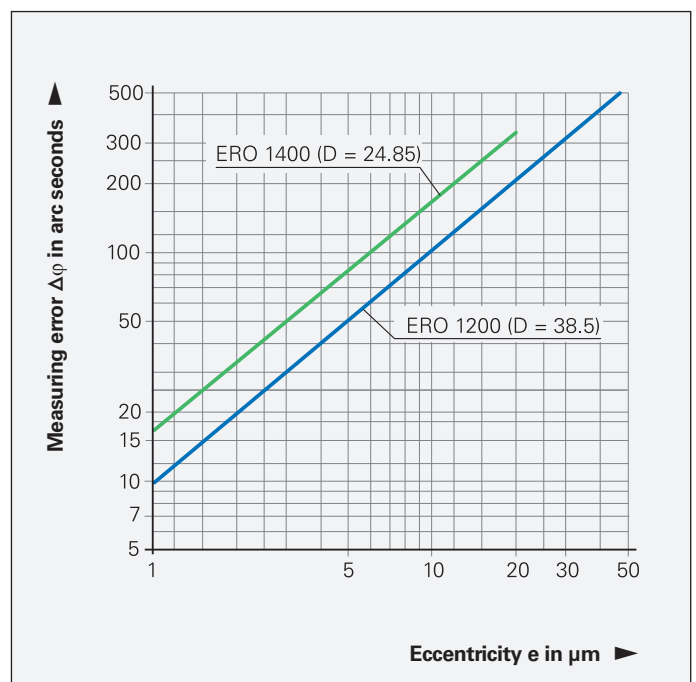

Resultant measuring error $\Delta\phi$ for various eccentricity values e as a function of the mean graduation diameter D

The following relationship exists between the eccentricity e , the mean graduation diameter D , and the measuring error $\Delta\varphi$ (see figure below):

$$\Delta\varphi = \pm 412 \cdot \frac{e}{D}$$

$\Delta\varphi$ = Measuring error in " (arc seconds)

e = Eccentricity of the radial grating relative to the bearing in μm

D = Mean graduation diameter in mm

Model	Mean graduation diameter D	Error per $1 \mu\text{m}$ of eccentricity
ERO 1420 ERO 1470 ERO 1480	$D = 24.85 \text{ mm}$	$\pm 16.5''$
ERO 1225 ERO 1285	$D = 38.5 \text{ mm}$	$\pm 10.7''$

3. Radial runout of the bearing

The stated relationship for the measuring error $\Delta\varphi$ also applies to the radial runout of the bearing when the eccentricity e is replaced by one half of the radial runout (half of the displayed value). Bearing compliance under a radial load applied to the shaft causes similar errors.

4. Position error within one signal period $\Delta\varphi_u$

The scanning units of all HEIDENHAIN encoders are adjusted such that, without any further electrical adjustment during mounting, the maximum position error within one signal period (listed below) is not exceeded.

Model	Line count	Position error within one signal period $\Delta\varphi_u$	
		TTL	1 V_{PP}
ERO	2048	$\leq \pm 19.0''$	$\leq \pm 6.5''$
	1500	$\leq \pm 26.0''$	$\leq \pm 8.7''$
	1024	$\leq \pm 38.0''$	$\leq \pm 13.0''$
	1000	$\leq \pm 40.0''$	$\leq \pm 14.0''$
	512	$\leq \pm 76.0''$	$\leq \pm 25.0''$

These values for the position error within one signal period are already included in the system accuracy. Greater error can arise if the mounting tolerances are exceeded.

Rotary encoders with inductive scanning

As with all rotary encoders without an integral bearing, the attainable accuracy of inductive-scanning encoders without an integral bearing depends on the mounting and application conditions. The stated system accuracy assumes a temperature of 20°C and a low shaft speed. The utilization of all permissible tolerances for the operating temperature, speed, supply voltage, scanning gap, and mounting condition must be taken into account for determining the typical total error.

Since inductive rotary encoders use circumferential scanning, their overall error is generally lower than that of optical rotary encoders without an integral bearing. Because overall error cannot be determined through a simple calculation, these values are provided in the following table.

Model	System accuracy	Total error
ECI 1100 EBI 1100 EQI 1100 EnDat22	$\pm 120''$	$\pm 280''$
ECI 1300 EQI 1300 EnDat22	$\pm 65''$	$\pm 120''$
ECI 100 EBI 100	$\pm 90''$	$\pm 180''$
ECI 4000 EBI 4000 90 mm hollow shaft EnDat22	$\pm 25''$	$\pm 140''$
ECI 4000 EBI 4000 180 mm hollow shaft EnDat22	$\pm 40''$	$\pm 150''$

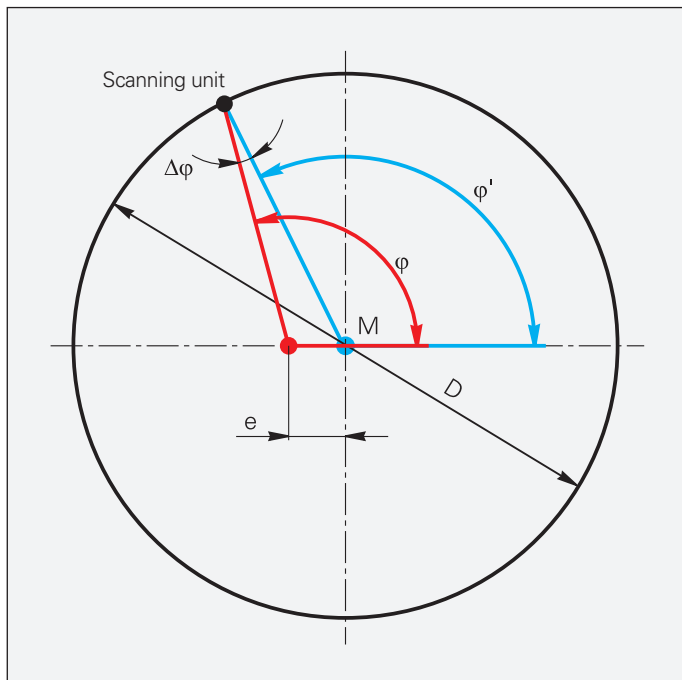

Dependency of the measuring error $\Delta\varphi$ on the mean graduation diameter D and the eccentricity e .

M = Center of graduation
 φ = "True" angle
 φ' = Scanned angle

Mechanical design types and mounting

Rotary encoders with integral bearing and stator coupling

The **ECN/EQN/ERN** rotary encoders feature an integral bearing and a mounted stator coupling. With these models, the encoder shaft is directly connected to the measured shaft. During angular acceleration of the shaft, the stator coupling must absorb only the torque arising from friction within the bearing. ECN/EQN/ERN rotary encoders thus exhibit excellent dynamic performance and a high natural frequency.

Benefits of the stator coupling:

- No axial mounting tolerance between the shaft and stator housing for the ExN 1300
- High natural frequency of the coupling
- High torsional rigidity of shaft coupling
- Minimized space requirement for external and internal mounting
- Easy axial mounting

Mounting the ECN/EQN 1100 and ECN/EQN/ERN 1300

The blind hollow shaft or the tapered shaft of the rotary encoder is connected at the encoder's front face to the measured shaft by way of a central screw. Proper centering onto the motor shaft is accomplished via the hollow shaft or tapered shaft. On its stator side, the ECN/EQN 1100 is connected to a plane surface with two clamping screws (without a centering collar). The stator side of the ECN/EQN/ERN 1300 is clamped in a mating hole by means of an axially tightenable screw.

Mounting accessories

ECN/EQN/ECI/EQI 1100: Mounting aid

Allows the encoder shaft to be turned from the rear to facilitate finding the positive-locking connection between the encoder and measured shaft.

ID 821017-03

ERN/ECN/EQN 1300: Inspection tool

For inspecting the shaft connection (fault exclusion for rotor coupling).

ID 680644-01

HEIDENHAIN recommends inspecting the holding torque of non-positive-locking shaft connections (e.g., tapered shafts, blind hollow shafts).

The inspection tool is screwed into the M10 back-off thread from the rear of the encoder. Due to the short thread engagement, the fastening screw for the shaft is not touched. With the motor shaft locked in place, the testing torque is applied to the extension by means of a torque wrench (hexagonal, width A/F: 6.3 mm). After any nonrecurring settling, it must be ensured that there is no relative motion between the motor shaft and the encoder shaft.

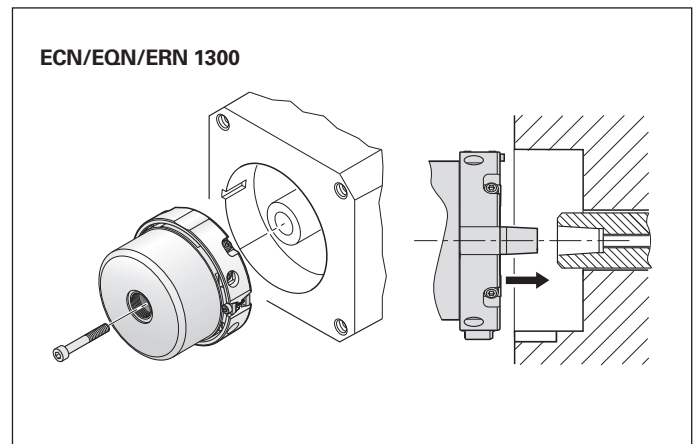
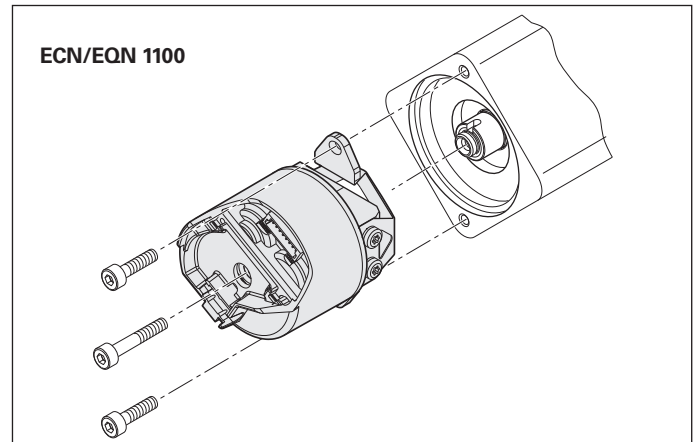

Mounting the ECN/EQN/ERN 1000 and ERN 1x23

The hollow shaft of these rotary encoders is slid onto the measured shaft and clamped on the rotor side with two screws. These encoders are mounted on the stator side without a centering flange onto a plane surface via four clamping screws or via two clamping screws and washers.

The ECN/EQN/ERN 1000 encoders have a blind hollow shaft, but the ERN 1123 has a hollow through shaft.

Accessory for ECN/EQN/ERN 1000

Washer

For increasing the natural frequency f_N when mounting with only two screws.
ID 334653-01 (2 pieces)

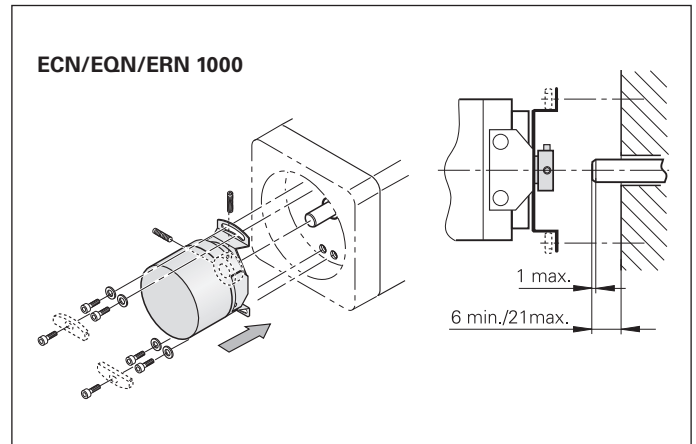

Mounting the EQN/ERN 400

The EQN/ERN 400 encoders are designed for use on asynchronous motors from Siemens and serve as replacements for existing Siemens rotary encoders.

The hollow shaft of the rotary encoder is slid onto the measured shaft and fastened by means of the clamping ring. On the stator side, the encoder's anti-rotation element is fastened to a plane surface.

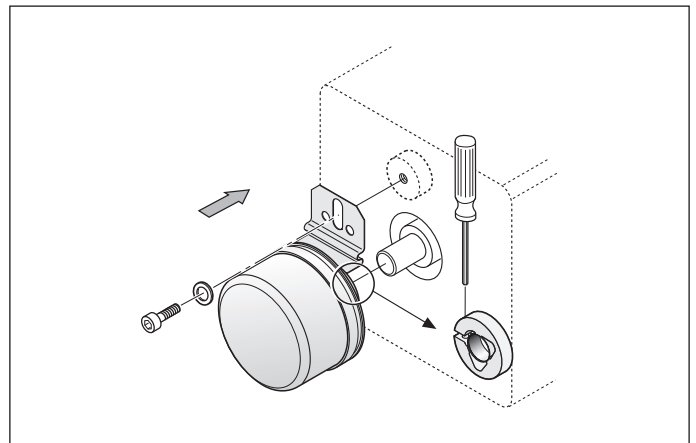

Mounting the ERN 401

The ERN 401 encoders are designed for use on Siemens asynchronous motors and serve as replacements for existing Siemens rotary encoders.

These rotary encoders have a solid shaft with an M8 external thread, centering taper, and a width A/F 8. The shaft self-centers as it is screwed into the motor shaft. The stator coupling is fastened to the motor's ventilation grille with special fastening clips.

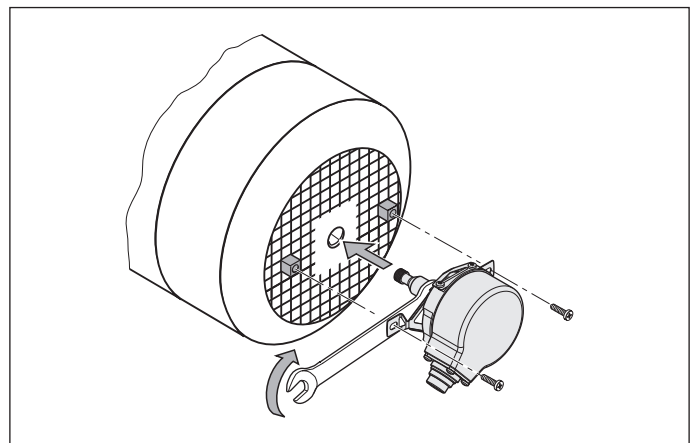

ECI/EBI/EQI rotary encoders without integral bearing

The **ECI/EBI/EQI** inductive encoders have no integral bearing. This means that the mounting and operating conditions influence the encoder's function reserves. It is also essential to ensure that the specified mating dimensions and tolerances are maintained for all operating conditions (see mounting instructions).

The application analysis must yield values within specification for all possible operating conditions (particularly under maximum load and at minimum and maximum operating temperature) and with the signal amplitude taken into account (inspection of the scanning gap and mounting tolerance at room temperature). This particularly applies to the following determined factors:

- Maximum radial runout of the motor shaft
- Maximum axial runout of the motor shaft relative to the mounting surface
- Maximum and minimum scanning gap (a), including in combination with, for example, the following:
 - The length ratio between the motor shaft and the motor housing under the influence of temperature ($T_1; T_2; \alpha_1; \alpha_2$), depending on the position of the fixed bearing (b)
 - The bearing play (C_x)
 - Non-dynamic shaft offsets due to load (X_1)
 - The effect of the motor brakes being engaged (X_2)

The **ECI/EBI 100** rotary encoders are pre-aligned on a plane surface and, with their hollow shaft locked, are slid onto the measured shaft. Fastening and shaft clamping are achieved with axial screws.

The **ECI/EBI/EQI 1100** inductive rotary encoders are mounted flush on their axis. Their blind hollow shaft is fastened with a central screw. The stator of these rotary encoders is clamped onto a shoulder with two axial screws.

Mounting accessory

Mounting aid for removing the PCB connector (see page 42).

Schematic representation of **ECI/EBI 100**

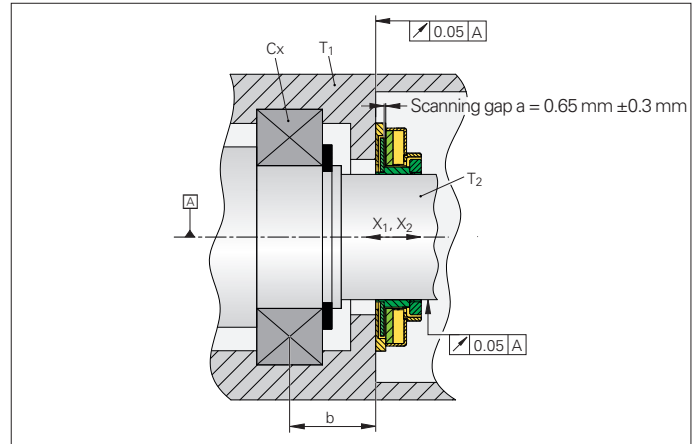

Mounting the **ECI 119**



Mounting the **ECI/EQI 1100**

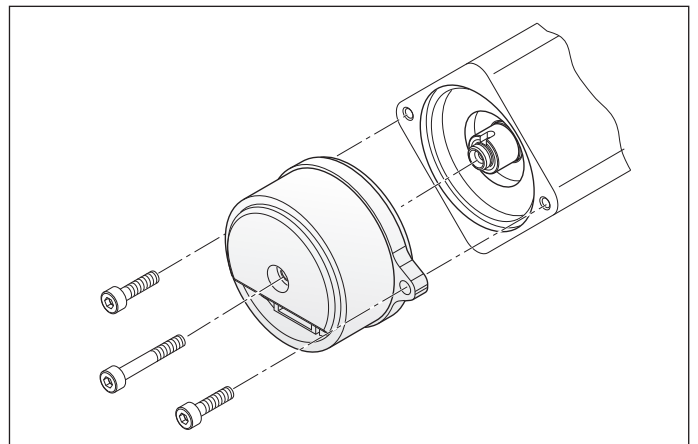

Permissible scanning gap

The size of the scanning gap between the rotor and the stator is dictated by the mounting situation. Later adjustment is possible only through the insertion of shim rings.

The maximum permissible error specified in the mating dimensions applies to both mounting and operation. Thus, the tolerances exploited during mounting are no longer available during operation.

Once the encoder has been mounted, the actual scanning gap between the rotor and the stator can be indirectly measured with the PWM 21 adjusting and testing package using a signal amplitude inside the rotary encoder. The characteristic curves illustrate the relationship between the signal amplitude and the deviation from the ideal scanning gap under different ambient conditions.

The example of the ECI/EBI 1100 shows the resulting deviation from the ideal scanning gap for a signal amplitude of 80 % under ideal conditions. Due to tolerances within the rotary encoder, the deviation is between +0.03 mm and +0.2 mm. Thus, the maximum permissible motion of the measured shaft during operation ranges from -0.33 mm to +0.1 mm (green arrows).

Display of the scanning gap

The latest generation of encoders supports the display of the mounting dimension in the ATS software. This additional data can also be requested by the drive during closed-loop operation.

ID	Exl mounting wizard	Mounting interface
728563-xx	✓	
820725-xx	✓	
1164809-xx		✓
1164811-xx		✓
1164812-xx		✓
1164813-xx		✓
811811-xx	✓	
811815-xx	✓	
810661-xx		✓
810662-xx		✓
823406-xx	✓	
823407-xx	✓	
823405-xx	✓	

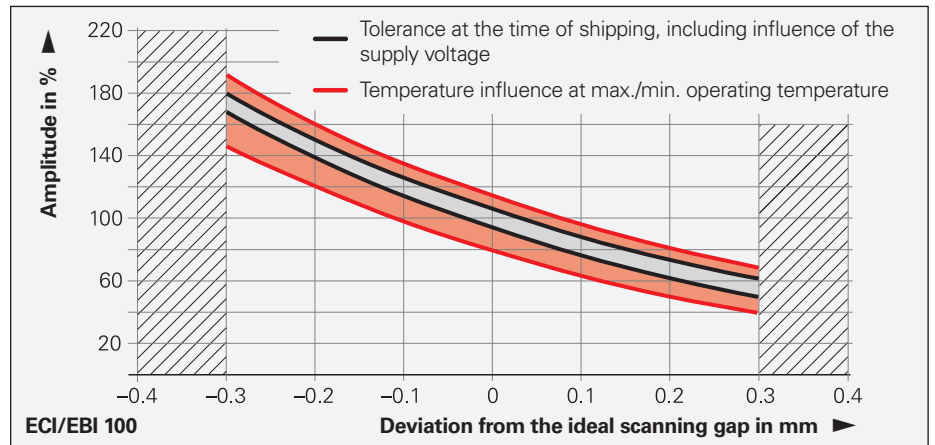
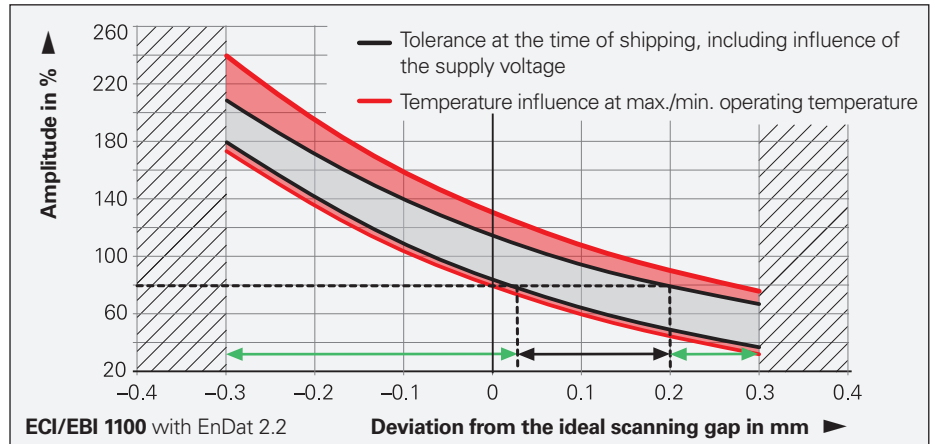

Online diagnostics [Open Loop]

Function reserves

- Absolute track**
▲ Minimum 100 % at 1324 rev. 337°
- Incremental- or sampling track**
▲ Minimum 100 % at 1324 rev. 337°
- Position-value formation**
▲ Minimum 100 % at 1324 rev. 337°

Mounting diagnostics

Mounting clearance [mm]
Minimum 1.041 mm at 1324 rev. 337°, Maximum 1.041 mm at 1324 rev. **1041**

The **ECI/EBI/EQI 1300** inductive rotary encoders are mounted flush on their axis. Their blind hollow shaft is fastened with a central screw. The stator of these rotary encoders is clamped to a shoulder by three axial screws.

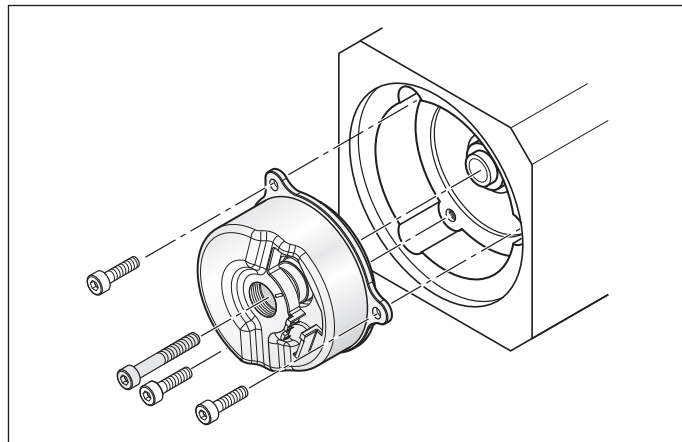

Mounting the **ECI/EQI 1300** EnDat22

The scale drum of the **ECI/EBI 4000** inductive rotary encoders is slid onto the centering collar of the measured shaft and fastened (with/without a key, depending on the version). Then the stator is fastened via an external centering diameter.

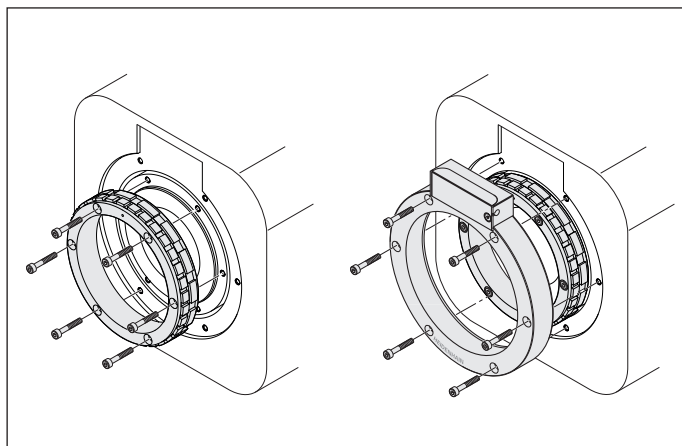

Mounting the **ECI/EBI 4000**

ERO rotary encoders without integral bearing

The **ERO** rotary encoders without an integral bearing consist of a scanning head and a graduated disk that must be brought into mutual alignment during mounting. Precise alignment is an important factor in reaching the attainable measuring accuracy.

The **ERO** modular rotary encoders consist of a disk/hub assembly and a scanning unit. These encoders are particularly well suited for limited installation space, low axial offsets, and low radial runout, or for applications where friction of any type must be avoided.

In the **ERO 1200** series, the disk/hub assembly is slid onto the shaft and brought into alignment with the scanning unit. The scanning unit is aligned on a centering collar and fastened to the mounting surface.

The encoders of the **ERO 1400** series are miniaturized modular rotary encoders. These encoders feature a special built-in **mounting aid** that centers the graduated disk relative to the scanning unit and adjusts the gap between the graduated disk and the scanning reticle. Short installation time can thus be attained. The encoder comes with a cover cap for protection against extraneous light.

Mounting accessories for the ERO 1400

Mounting accessory

Aid for removing the clip in order to achieve optimal encoder mounting.
ID 510175-01

Accessory

Housing for the ERO 14xx with an axial PCB connector and central hole.
ID 331727-23

Mounting the **ERO**

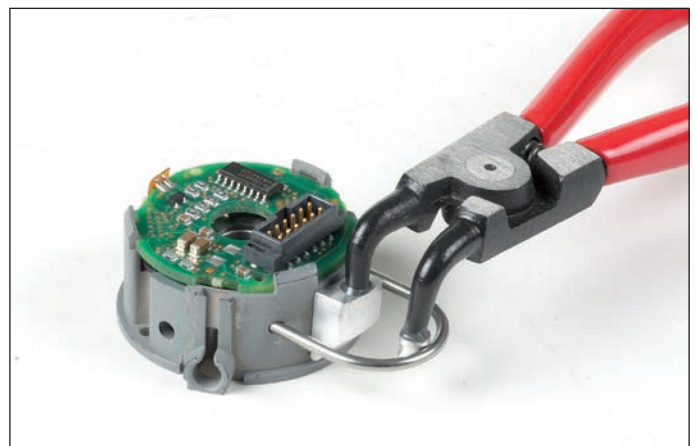
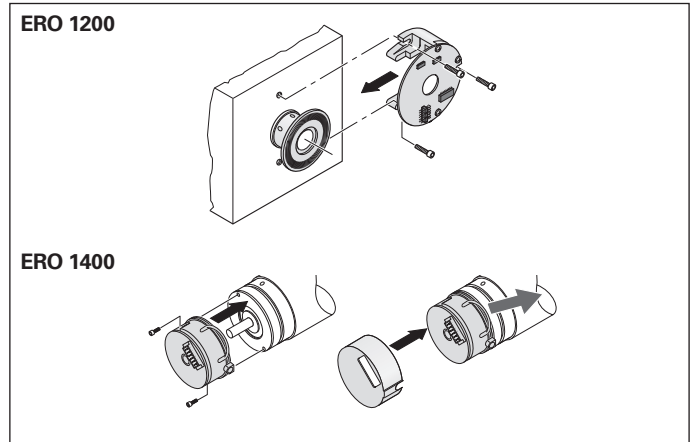

Mounting accessories for the **ERO 1400**

Information on output cables

Mounting and commissioning must be performed with appropriate ESD protection. Do not engage or disengage the connecting element when it is under power. To avoid overstressing the individual wires during disengagement of the connecting element, HEIDENHAIN recommends using the mounting aid for disconnecting the PCB connector.

Strain relief

Avoid torque or tensile stress, and use strain relief wherever necessary.

Straight M12 flange socket

Retention force of polarizing key:
max. 1 Nm.

Screws

For output cables with standard M12 or M23 flange sockets, use M2.5 screws.

The mounting method with M2.5 screws was designed for the following tightening torques:

For M12, M23:	Min. M_d	0.4 Nm
	Max. M_d	0.5 Nm
Load-bearing thread length:	min.	4 mm
Minimum tensile strength of the screws:		800 N/mm ²

To prevent self-loosening of the screws, HEIDENHAIN recommends using a material bonding threadlocker.

Accessory

Mounting aid for disengaging the PCB connector. Suitable for all rotary encoders in this brochure, except for the ERO 1200 series (ID 1075573-01).

To avoid damaging the cable, apply pulling force only to the connector and never to the wires. For other encoders, use tweezers or the mounting aid as needed.

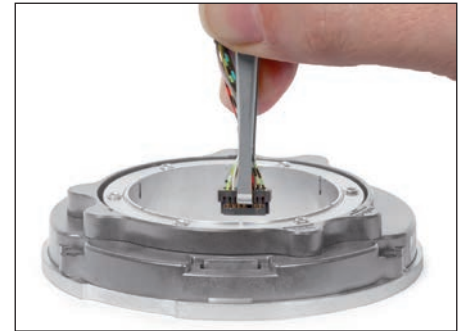

Mounting aid for PCB connector

Cable length (rated length)

For output cables with a crimp on the encoder side for strain relief and a shield contact, the cable length is specified up to the crimp sleeve. Exceptions apply, for example, to output cables without a crimp on the encoder side and to those with a sensor connection at the subsequent electronics or with a shield connection clamp. Upon request, you can obtain binding information (a dimension drawing) corresponding to the ID number of the respective output cable (see *Cables and connecting elements*).

Electromagnetic compatibility

Cables from HEIDENHAIN are tested for electromagnetic compatibility. For output cables with wires for temperature sensors, conformity with the EMC Directive in the complete system must be documented.

Crimp connector

For joining (crimping) the wires of the temperature-sensor output cable to the wires of the temperature sensor inside the motor (ID 1148157-01).

For information on the appropriate crimping tools, please refer to the *HMC 6* Product Information document.

Designation of the cable components

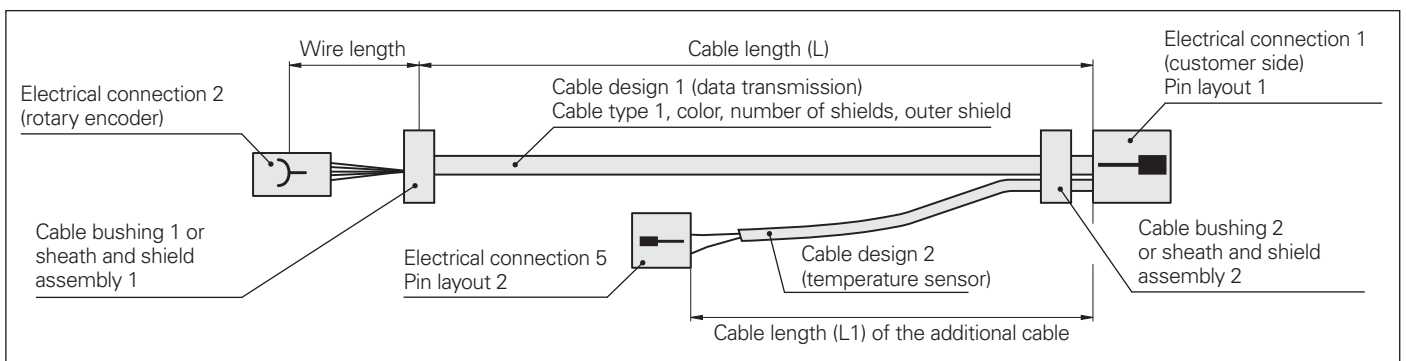

Temperature sensor signals via electrical connection 1

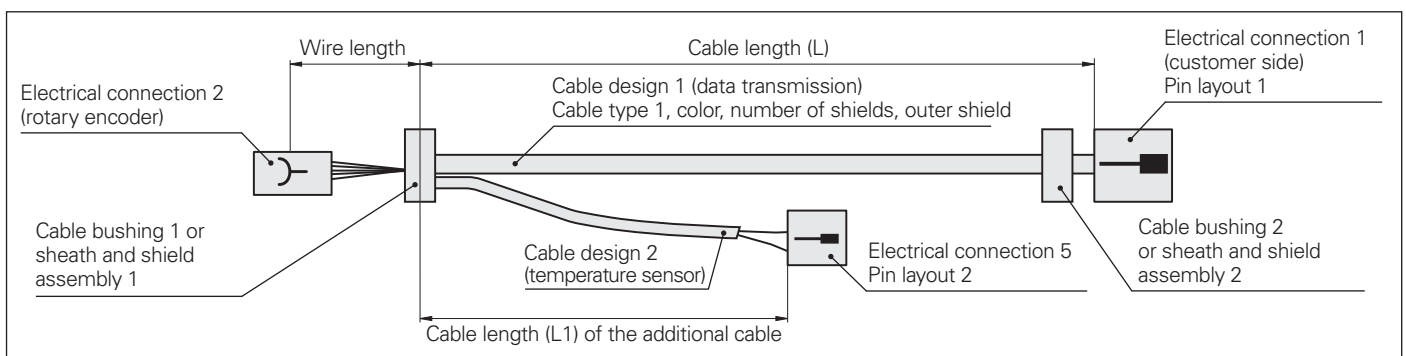

Temperature sensor signals via rotary encoder PCBA

General testing accessories for modular encoders and the PWM 21

Testing cable for modular rotary encoders with the EnDat22, EnDat01, SSI, and DRIVE-CLiQ interfaces

Includes three 12-pin adapter connectors and three 15-pin adapter connectors.
ID 621742-01

Adapter connectors

Three connectors for replacement.
12-pin: ID 528694-01
15-pin: ID 528694-02

Connecting cable for the EnDat22, EnDat01, and SSI interfaces

For extending the testing cable; completely assembled with a 15-pin D-sub connector (male) and a 15-pin D-sub connector (female), max. 3 m.
ID 1080091-xx

Adapter cable for DRIVE-CLiQ, Ø 6.8 mm

15-pin D-sub (female) and 6-pin RJ45 Ethernet connector with IP20 metal housing.
ID 1228399-01

Testing cable for the ERN 138xx, with commutation signals for sinusoidal commutation

Includes three 14-pin adapter connectors.
ID 1118892-02

Adapter connectors

Three connectors for replacement.
ID 528694-04

Adapter cables for connecting the flange socket on the motor to the PWM 21

Adapter cable Ø 6 mm for the EnDat22 interface

9-pin M23 connector (female)
8-pin M12 coupling (male).
ID 1136863-xx
(ID 524599-xx is additionally required: 15-pin M12 (female) and 15-pin D-sub connector (male))

Adapter cables, Ø 6 mm/8 mm

8-pin M12 connector (female)
15-pin D-sub connector (male).
ID 1036526-xx Ø 6 mm
ID 1129753-xx Ø 8 mm

Adapter cable Ø 6.8 mm for the DRIVE-CLiQ interface

9-pin M23 connector (female)
6-pin RJ45 Ethernet connector with IP20 metal housing.
ID 1117540-xx

Adapter cable, Ø 6.8 mm

8-pin M12 connector (female)
6-pin RJ45 Ethernet connector with IP20 metal housing.
ID 1093042-xx

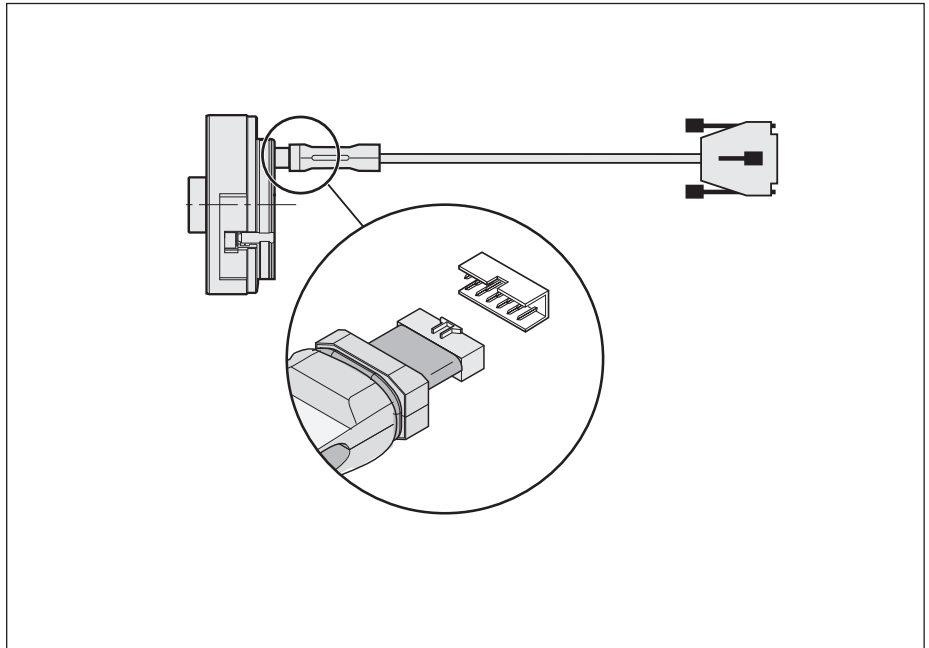

Testing cable for modular rotary encoders

Connecting cable

For extending the testing cable
Completely assembled with 15-pin D-sub connector (male) and 15-pin D-sub connector (female), max. 3 m.
ID 675582-xx

Adapter cable Ø 8 mm for the EnDat01, EnDat Hx, EnDat Tx, or SSI interface with incremental signals

17-pin M23 connector (female)
15-pin D-sub connector (male).
ID 324544-xx

Adapter cable Ø 8 mm

12-pin M23 connector (female)
15-pin D-sub connector (male).
ID 310196-xx

Adapter cable Ø 13.6 mm, version for HMC 6

M23 SpeedTEC hybrid connector (female), five power wires, two brake wires, and six communication wires;
15-pin D-sub connector (male).
ID 1189174-xx

DRIVE-CLiQ is a registered trademark of Siemens AG.

SpeedTEC is a registered trademark of TE Connectivity Industrial GmbH.

Compatible mounting dimensions

Mating dimensions and tolerances must be taken into account during the mounting of rotary encoders. Within some rotary encoder series, the mating dimensions may exhibit only slight differences or even be identical. Certain rotary encoders are therefore mounting-compatible with each other, allowing different encoders to be mounted to the same motor as the requirements dictate.

All dimensions, tolerances, and required mating dimensions are indicated in the dimension drawing of the respective series. Deviating values for rotary encoders with functional safety (FS) are provided in the corresponding Product Information documents.

All absolute rotary encoders of the ECN/ EQN 1100 FS, ECI/EQI 1100 FS, ECI/EBI 1100, and ECI/EQI 1100 series are mounting-compatible with each other, exhibiting only minor differences in the permissible deviation between the shaft surface and coupling surface.

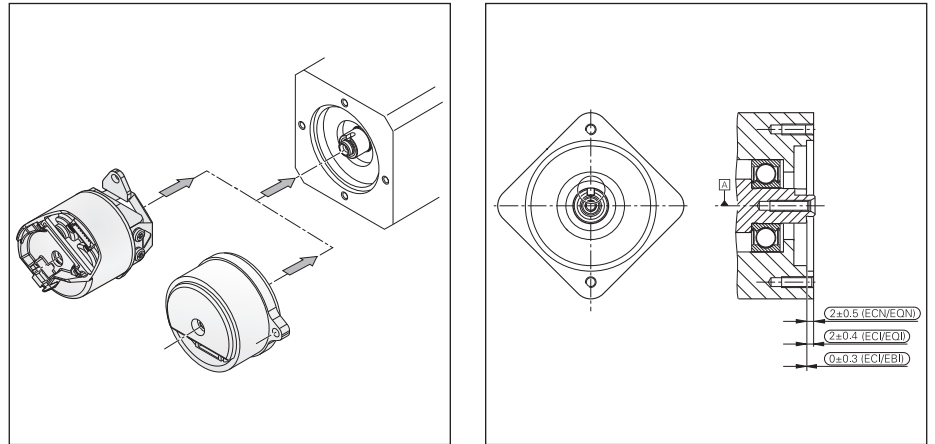

Series	Differences
ECN/EQN 1100 FS	Standard, with slot for FS devices
ECI/EQI 1100 FS	Same as ECN/EQN 1100 FS, but with a different tolerance for the deviation between the shaft and coupling surfaces
ECI/EBI 1100	Same as ECN/EQN 1100 FS, but with a different tolerance for the deviation between the shaft and coupling surfaces
ECI/EQI 1100	Same as ECN/EQN 1100 FS, but with a different tolerance for the deviation between the shaft and coupling surfaces

Some rotary encoders of the ERN 1300, ECN/EQN 1300, ECI/EBI/EQI 1300 FS, and ECN/EQN 400 series are also mounting-compatible with each other and can be mounted to identical motors. Minor differences, such as the anti-rotation element and a limited tolerance for the inside diameter, must be taken into account.

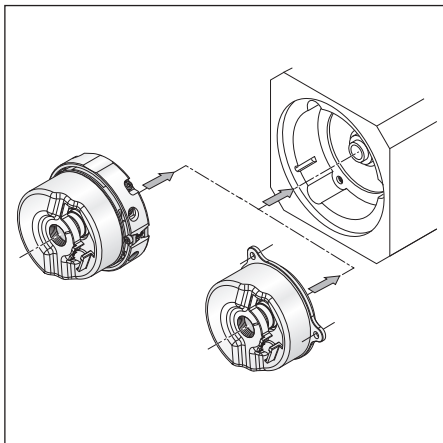

Series	Required mating dimensions			
	ERN 1300	ECN/ EQN 1300 FS	ECI/EBI/ EQI 1300 FS	ECN/ EQN 400 FS
ERN 1300		✓	✓	✓
ECN/EQN 1300 FS			✓	✓
ECI/EQI 1300 FS				
ECN/EQN 400 FS		✓	✓	

Series	Differences
ERN 1300	Standard, deployable for taper shaft
ECN/EQN 1300	Same as ERN 1300, but with an additional ridge as an anti-rotation element (stator coupling)
ECI/EBI/EQI 1300 FS	Same as ERN 1300, but with an anti-rotation element (flange)
ECN/EQN 400	Same as ECN/EQN 1300

Mounting accessories

Screwdriver bits

- For HEIDENHAIN shaft couplings
- For ExN shaft clampings and stator couplings
- For ERO shaft clampings

Width across flats	Length	ID
1.5	70 mm	350378-01
1.5 (spherical head)		350378-02
2		350378-03
2 (spherical head)		350378-04
2.5		350378-05
3 (spherical head)		350378-08
4		350378-07
4 (with dog point) ¹⁾		350378-14
	150 mm	756768-44
TX8	89 mm	350378-11
	152 mm	350378-12
TX15	70 mm	756768-42

Screwdriver

When using screwdrivers with adjustable torque, make sure that they comply with DIN EN ISO 6789 for fulfilling the required torque tolerances.

Adjustable torque, with accuracy of $\pm 6\%$
 0.2 Nm to 1.2 Nm ID 350379-04
 1 Nm to 5 Nm ID 350379-05



¹⁾ For screws as per DIN 6912 (low head screw with pilot recess)

Screws

Screw	Securing method	ID
M3x8 8.8 ISO 4762 MKL	Material bonding anti-rotation lock	202264-67
M3x10 8.8 ISO 4762 MKL	Material bonding anti-rotation lock	202264-87
M3x16 A2 ISO 4762 KLF	Self-locking	202264-30
M3x20 A2 ISO 4762 KLF	Self-locking	202264-45
M3x22 8.8 ISO 4762 MKL	Material bonding anti-rotation lock	202264-65
M3x25 8.8 ISO 4762 MKL	Material bonding anti-rotation lock	202264-86
M3x25 A2 ISO 4762 KLF	Self-locking	202264-26
M3x35 8.8 ISO 4762 MKL	Material bonding anti-rotation lock	202264-66
M4x10 8.8 ISO 4762 MKL	Material bonding anti-rotation lock	202264-85
M5x25 08.8 DIN 6912 MKL	Material bonding anti-rotation lock	202264-55
M5x30 08.8 DIN 6912 MKL	Material bonding anti-rotation lock	202264-76
M5x35 8.8 ISO 4762 KLF	Self-locking	202264-80
M5x50 08.8 DIN 6912 KLF	Self-locking	202264-36
M5x50 08.8 DIN 6912 MKL	Material bonding anti-rotation lock	202264-54
Fastener kit	Material bonding anti-rotation lock	20 pieces: 1264352-01
<ul style="list-style-type: none"> • M3 fixing clamp • Spring washer: 3x0.70 DIN 128 A-FS ISO • Screw: M3x10 8.8 DIN EN ISO 4762 		200 pieces: 1264352-02

General information

Alignment of rotor positions between encoders and motors

Immediately after a synchronous motor is switched on, information is needed about its absolute rotor position. Rotary encoders with additional commutation signals are suitable for this task but provide comparatively rough position information. Absolute rotary encoders in singleturn or multiturn designs are also well suited, delivering the exact angular position down to an accuracy of a few arc seconds (see also *Electronic commutation with position encoders*). To achieve the most constant motor currents possible, the rotor positions of the motor and of the encoder must be brought into mutual alignment when the encoder is mounted. Inadequate alignment of the rotor positions will cause significant motor noise and high power dissipation.

First, the rotor of the motor is turned to the preferred position through the application of a DC current.

Rotary encoders with commutation signals are then roughly aligned (e.g., using the line markers on the encoder or the reference mark signal) and are mounted to the motor shaft. Fine adjustment is then performed with the PWT 101 testing device (see *Diagnostics, and inspection and testing equipment*): the stator of the rotary encoder is turned until the PWT 101 displays a distance from the reference mark of nearly zero.

Absolute rotary encoders are first completely mounted, after which a datum shift is used to assign the value "zero" to the preferred motor position. This is performed with the adjusting and testing package (see *Diagnostics, and inspection and testing equipment*). This package features complete EnDat functionality, allowing not only datum shifts but also the use of other inspection functions and the setting of write-protection to prevent unintentional changes to saved values.

For the ECI/EQI rotary encoders with additional 1 V_{PP} signals, manual adjustment is possible as well. Please follow the information in the respective mounting instructions.

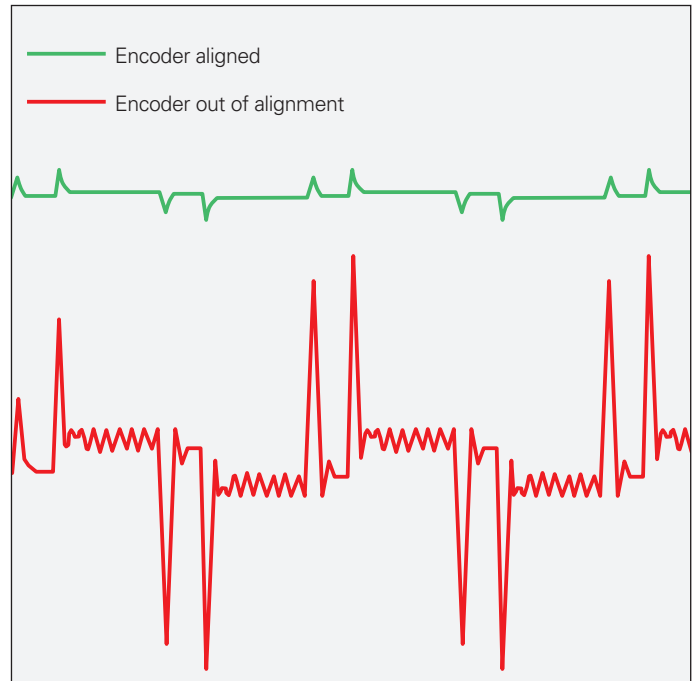

Motor current of an encoder when aligned and significantly out of alignment

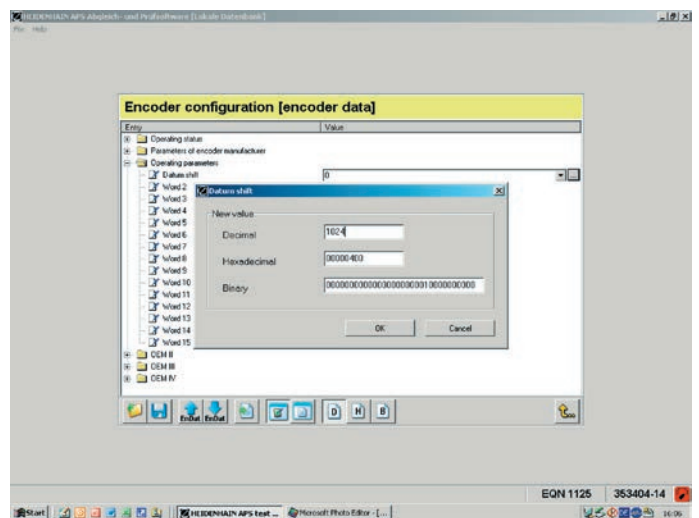

Alignment of the rotor positions by means of the adjusting and testing package

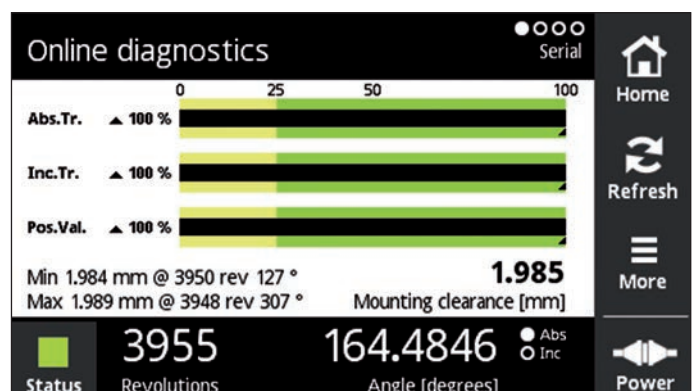

Online diagnostics of the PWT 101

General mechanical information

Certification by NRTL (Nationally Recognized Testing Laboratory)

All of the rotary encoders in this brochure comply with the UL safety regulations for the U.S. and the CSA safety regulations for Canada.

Types of acceleration

During mounting and operation, encoders are subjected to various forms of acceleration.

• Vibration

The encoders are qualified on a test stand under the acceleration values stated in the specifications at frequencies of 55 Hz to 2000 Hz in accordance with EN 60068-2-6. However, if the application or mounting situation causes long-duration resonant vibration during operation, then proper functioning of the encoder may be impaired, or the encoder may incur damage. **Thorough testing of the complete system is therefore required.**

• Shock

The encoders are qualified on a test stand under the acceleration values stated in the specifications and under the exposure times in accordance with EN 60068-2-27 for non-repetitive, semi-sinusoidal shock.

Continuous shock loads are therefore not covered and **must be tested in the application.**

- The **maximum angular acceleration** is 10^5 rad/s^2 . This is the maximum permissible angular acceleration of the rotor without the encoder incurring damage. The actual attainable angular acceleration is within the same order of magnitude but can vary depending on the type of shaft connection (for deviating values for the ECN/ERN 100, see the *Specifications*). An adequate safety factor must be determined through system tests.

Deviating values for rotary encoders with functional safety are provided in the corresponding Product Information documents.

Natural frequencies

In conjunction with the stator coupling, the **ECN/EQN/ERN** rotary encoders form an oscillation-capable spring-mass system whose **natural frequency f_N** of the coupling should be as high as possible in the direction of measurement. The natural frequency of the coupling is influenced by the rigidity of the stator coupling and by the customer-side mounting situation.

The stated typical natural frequencies may vary depending on the encoder variant (e.g., singleturn or multiturn), production tolerances, and various mounting conditions. If radial and/or axial accelerations also come into play, then the rigidity of the encoder bearing and of the encoder stator also has an effect. If such loads occur within your application, HEIDENHAIN recommends consulting with the main facility in Traunreut, Germany.

HEIDENHAIN generally recommends determining the natural frequency of the stator coupling in the complete system.

Humidity

The maximum permissible relative humidity is 75 %. A relative humidity of 93 % is temporarily permissible. Condensation is not permissible.

Magnetic fields

Magnetic fields > 30 mT can affect encoder functioning. Please contact HEIDENHAIN in Traunreut, Germany, as needed.

Acoustic noise

Running noise can occur during operation. This is particularly true in the case of encoders with an integral bearing, as well as multiturn rotary encoders (with gears). The intensity may vary depending on the mounting situation and shaft speed.

Starting torque and operating torque

The starting torque is the torque required to initiate rotor motion from standstill. If the rotor is already rotating, then a certain operating torque is acting on the encoder. The starting torque and operating torque are influenced by various factors, such as the temperature, prior standstill time, and the amount of wear on the bearings and seals.

The typical values stated in the specifications are mean values based on encoder-specific test series performed at room temperature and at a stabilized operating temperature. The typical operating torques are also based on constant shaft speeds. For applications in which the torque has a significant influence, HEIDENHAIN recommends consulting with the main facility in Traunreut.

Protection against contact (EN 60529)

After completed installation of the encoder, any rotating parts must be sufficiently protected from unintentional contact during operation.

Protection class EN 60529

The ingress of contamination can impair proper functioning of the encoder. Unless otherwise indicated, all of the rotary encoders have an IP64 rating (ExN/ROx 400: IP67) in accordance with EN 60529. These specifications apply to the housing, cable outlet, and flange socket versions when engaged.

The **shaft inlet** meets an IP64 rating. Splash water must not be allowed to have any harmful effect on the encoder's parts. If the protection class of the shaft inlet is not sufficient (e.g., due to vertical mounting of the encoder), then the encoders should be additionally protected with labyrinth seals. Many rotary encoders are also available with an IP66 rating for the shaft inlet. Depending on the application, the radial shaft seal rings used for sealing are subjected to wear due to friction.

System tests

Encoders from HEIDENHAIN are usually integrated as components into complete systems. Such applications require **comprehensive testing of the complete system**, irrespective of the encoder's specifications.

The specifications provided in this brochure apply only to the encoder and not to the complete system. Any operation of the encoder outside of the specified range or outside of its proper and intended use is solely at the user's own risk.

Mounting

The applicable steps and dimensions that must be complied with during mounting are specified solely in the mounting instructions supplied with the device. All mounting-related information in this brochure is therefore solely provisional and non-binding, and will not become the subject matter of a contract.

All of the provided information on screw connections assumes a mounting temperature of 15 °C to 35 °C.

Screws with material bonding anti-rotation lock

Mounting screws and central screws from HEIDENHAIN (not included in delivery) feature a coating that, after hardening, provides a material bonding anti-rotation lock. As a result, these screws cannot be reused. Their minimum shelf life is two years (storage at ≤ 30 °C and ≤ 65 % relative humidity). Their expiration date is printed on the package.

Screw insertion and the application of tightening torque must therefore be completed within five minutes. The required strength is reached at room temperature after six hours. The lower the temperature is, the longer the curing process will take. Curing temperatures below 5 °C are not permissible. Screws with material bonding anti-rotation lock must not be used more than once. If a replacement becomes necessary, recut the threads and use new screws. A chamfer is required on threaded holes in order to prevent the coating from being scraped off.

For the fault exclusion design for functional safety, the following material properties and conditions for the mating surfaces are assumed:

	Aluminum	Steel
Material type	Hardenable wrought aluminum alloy	Unalloyed hardened steel
Tensile strength R_m	≥ 220 N/mm ²	≥ 600 N/mm ²
Yield strength $R_{p0.2}$ or yield point R_e	Not applicable	≥ 400 N/mm ²
Shear strength τ_a	≥ 130 N/mm ²	≥ 390 N/mm ²
Interface pressure p_G	≥ 250 N/mm ²	≥ 660 N/mm ²
Modulus of elasticity E (at 20 °C)	70 kN/mm ² to 75 kN/mm ²	200 kN/mm ² to 215 kN/mm ²
Coefficient of thermal expansion α_{therm} (at 20 °C)	$\leq 25 \cdot 10^{-6} \text{K}^{-1}$	$10 \cdot 10^{-6} \text{K}^{-1}$ to $17 \cdot 10^{-6} \text{K}^{-1}$
Surface roughness R_z	≤ 16 μm	
Friction values	Mounting surfaces must be clean and free of grease. Use screws from HEIDENHAIN in their delivery condition.	
Tightening procedure	Use a signal-emitting torque wrench in accordance with DIN EN ISO 6789, with an accuracy of ± 6 %	
Mounting temperature	15 °C to 35 °C	

Modifications to the encoder

The proper functioning and accuracy of encoders from HEIDENHAIN are ensured only if the encoders have not been modified. Any modification, even a minor one, can impair the proper functioning, reliability, and safety of the encoders, and result in a loss of warranty. This also includes the use of any additional or non-prescribed locking varnishes, lubricants (e.g., for screws), or adhesives. If you are in doubt, we recommend that you consult with HEIDENHAIN in Traunreut, Germany.

Conditions for longer storage periods

For a storage period of twelve months or longer, HEIDENHAIN recommends the following:

- Leave the encoders in their original packaging
- The storage location should be dry, free of dust, and temperature-regulated. It should also be devoid of vibration, mechanical shock, and chemical environmental influences
- Every twelve months, rotate the shafts of those encoders with an integral bearing at low speed and without axial or radial shaft loading so that the bearing lubrication becomes evenly redistributed (e.g., such as when first breaking in an encoder)

Parts subject to wear

Encoders from HEIDENHAIN are designed for a long service life. Preventive maintenance is not required. However, they do contain components that are subject to wear depending on the application and how they are deployed. This especially applies to cables subjected to frequent flexing.

Other parts subject to wear are the bearings in encoders with integral bearing, the radial shaft seal rings in rotary encoders and angle encoders, and the sealing lips on linear encoders.

In order to avoid damage from current flows, some rotary encoders are available with hybrid bearings. In general, these bearings exhibit greater wear at high temperatures than is the case with standard bearings.

Service life

Unless otherwise specified, HEIDENHAIN encoders are designed for a service life of 20 years, which is equivalent to 40000 operating hours under typical operating conditions.

Temperature ranges

For encoders still in their packaging, a **storage temperature range** of $-30\text{ }^{\circ}\text{C}$ to $65\text{ }^{\circ}\text{C}$ applies (HR 1120: $-30\text{ }^{\circ}\text{C}$ to $70\text{ }^{\circ}\text{C}$). The **operating temperature range** specifies the temperatures that a rotary encoder is permitted to reach during operation in the actual installation environment. Within this range, proper functioning of the rotary encoder is ensured. The operating temperature is measured at the defined measuring point (see dimension drawing) and must not be confused with the ambient temperature.

The temperature of the rotary encoder is influenced by the following factors:

- Mounting situation
- Ambient temperature
- Encoder self-heating

An encoder's susceptibility to self-heating depends both on its design characteristics (stator coupling / solid shaft, shaft sealing ring, etc.) and on its operating parameters (shaft speed, supply voltage). A temporary period of intensified self-heating can also occur after very long breaks in operation (of several months). Please allow for a two-minute break-in period at low shaft speeds. The greater susceptibility to self-heating that an encoder exhibits, the lower the ambient temperature needs to be in order to keep the encoder within its permissible operating temperature range.

This table shows the approximate self-heating values to be expected for the rotary encoders. In the worst case scenario, the amount of self-heating may be affected by multiple operating parameters, such as a 30 V supply voltage and operation at maximum shaft speed. Thus, if an encoder is being operated close to its maximum permissible specifications, the actual operating temperature should be measured directly at the encoder. Suitable measures must then be taken (fans, heat sinks, etc.) to sufficiently reduce the ambient temperature so that the maximum permissible operating temperature will not be exceeded during continuous operation.

For high shaft speeds at the maximum permissible ambient temperature, special versions with a reduced protection class are available (without a radial shaft seal ring and its concomitant frictional heat).

Self-heating at shaft speed n_{\max}

<i>Solid shaft / tapered shaft</i> ExN 400/1300	$\approx +5\text{ K}$ $\approx +10\text{ K}$ with IP66 protection
<i>Blind hollow shaft</i> ECN/EQN/ ERN 400/1300	$\approx +30\text{ K}$ $\approx +40\text{ K}$ with IP66 protection
ECN/EQN/ ERN 1000	$\approx +10\text{ K}$
<i>Hollow through shaft</i> ECN/ERN 100 ECN/EQN/ERN 400	$\approx +40\text{ K}$ with IP64 protection $\approx +50\text{ K}$ with IP66 protection

Typical self-heating values of a rotary encoder at maximum permissible shaft speed based on its design characteristics. The relationship between shaft speed and heat generation is nearly linear.

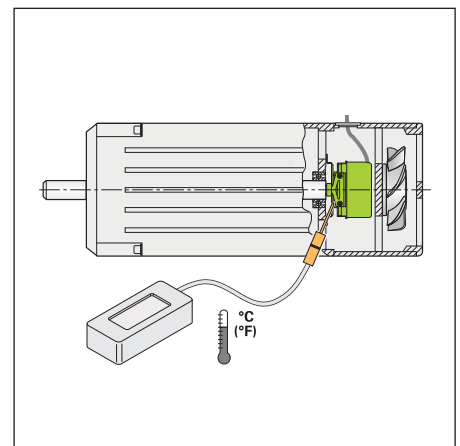

Measuring the actual operating temperature at the defined measuring point of the rotary encoder (see *Specifications*)

Electrical resistance

Encoders with an integral bearing, pluggable output cable, and standard bearing

Check the resistance between the flange socket and the rotor.

Nominal value: < 1 ohm

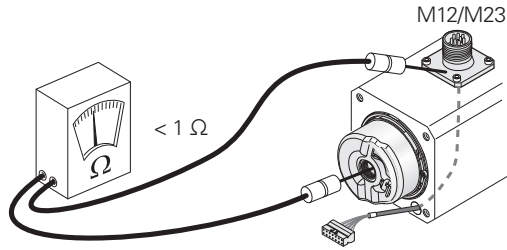

Exposed encoders (Exl 100) without integral bearing but with a pluggable cable

Check the electrical resistance between the flange socket and the rotor **a)**, and between the flange socket and the stator (mounting screw) **b)**.

Nominal value: < 1 ohm

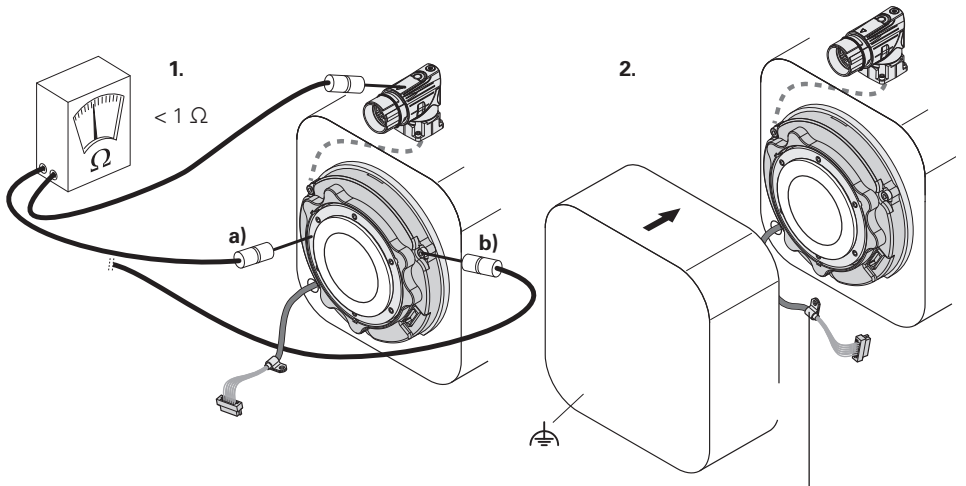

Clamp must be screwed to the motor housing so as to be conductive. Conformity with the EMC Directive must be ensured in the complete system.

Exposed encoders (Exl 4000) without an integral bearing but with a pluggable output cable

Check the electrical resistance between the flange socket and the rotor **a)**, the flange socket and the stator **b)**, and the flange socket and the crimp sleeve **c)**.

Nominal value: < 1 ohm

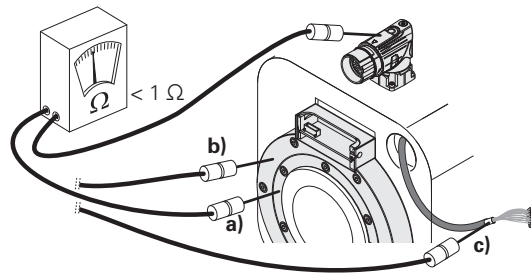

Exposed encoders (Exl 1100) without an integral bearing but with a pluggable output cable

Check the resistance between the flange socket and the rotor **a)**, and between the flange socket and the stator (metal housing) **b)**.

Nominal value: < 1 ohm

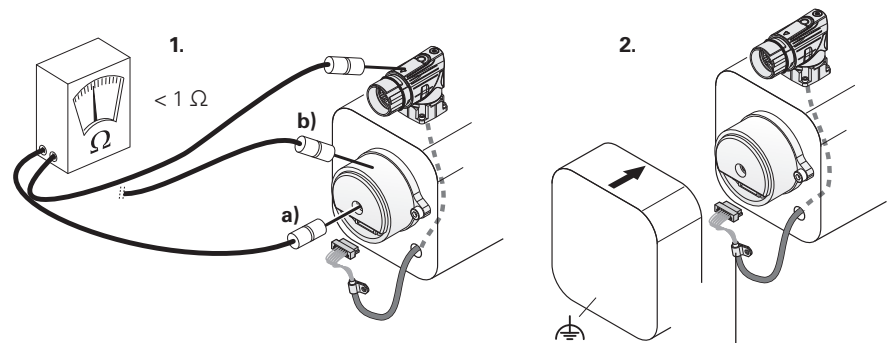

Clamp (when present) must be screwed to the motor housing so as to be conductive. Conformity with the EMC Directive must be ensured in the complete system.

Temperature measurement in motors

Transmission of temperature values

To protect the motor from overloads, the motor manufacturer usually monitors the temperature of the motor winding. In classic applications, the temperature sensor data are sent via two separate lines to the subsequent electronics, where they are then evaluated. Depending on their version, HEIDENHAIN rotary encoders with the EnDat 2.2 interface feature an internal temperature sensor integrated into the encoder electronics and an evaluation circuit for connection to an external temperature sensor. In both cases, the respective digitized temperature value is transmitted purely serially via the EnDat protocol (as part of the additional data). As a result, no separate lines are needed from the motor to the motor controller.

Signaling of a temperature exceedance

When it comes to the internal temperature sensor, such rotary encoders can support the dual-level cascaded signaling of a temperature exceedance. This signaling consists of an EnDat warning and an EnDat error message.

The following addresses in the integrated memory can be read to determine whether the respective encoder supports this warning and error message functionality:

- EnDat warning for *excessive temperature*: EnDat memory area *Parameters of the encoder manufacturer*, word 36 *Support of warnings*, bit 2¹ *Temperature exceeded*
- EnDat error message for *excessive temperature*: EnDat memory area *Parameters of the encoder manufacturer for EnDat 2.2*, word 35 *Support of operating condition error sources*, bit 2⁶ *Temperature exceeded*

Encoder	Interface	Internal temperature sensor ¹⁾	External temperature sensor connection
ECI/EQI 1100	EnDat22	✓ (±1 K)	Possible
ECI/EBI 1100	EnDat22	✓ (±5 K)	–
ECN/EQN 1100	EnDat22	✓ (±5 K)	Possible
	EnDat01	–	–
	DQ	✓ (±7 K)	Possible (±7 K)
ECN/EQN 1300	EnDat22	✓ (±4 K)	Possible
	EnDat01	–	–
	DQ01	✓ (±7 K)	Possible
ECN/EQN 400	EnDat22	✓ (±4 K)	Possible
	EnDat01	–	–
ECI/EBI/EQI 1300	EnDat22	✓ (±1 K)	Possible
ECI 1319S/ EQI 1331S	DQ	✓ (±1 K)	Possible
ECI/EBI 100	EnDat22	✓ (±4 K)	Possible
	EnDat01	–	–
ECI/EBI 4000	EnDat22	✓ (±1 K)	Possible

¹⁾ In parentheses: accuracy at 125 °C

In compliance with the EnDat specification, when the temperature reaches the warning threshold for excessive temperature of the internal temperature sensor, it triggers an **EnDat warning** (EnDat memory area *Operating status*, word 1 *Warnings*, bit 2¹ *Temperature exceeded*). This warning threshold for the internal temperature sensor is stored in the EnDat memory area *Operating parameters*, word 6 *Threshold sensitivity warning bit for exceeded temperature*, and can be individually adjusted. At the time the encoder is shipped, a default value corresponding to the maximum permissible operating temperature is stored here (temperature at measuring point M1 as per the dimension drawing). The temperature measured by the internal temperature sensor is higher by a device-specific amount than the temperature at measuring point M1.

The encoder features a further, albeit non-adjustable trigger threshold of the internal temperature sensor, which, when exceeded, triggers an **EnDat error message** (EnDat memory area *Operating status*, word 0 *Error messages*, bit 2² *Position* and in additional data 2 *Operating status error sources*, bit 2⁶ *Temperature exceeded*). This trigger threshold is device-specific and, if present, is stated in the specifications.

HEIDENHAIN recommends adjusting the warning threshold based on the application such that this threshold is sufficiently below the trigger threshold for the *Temperature exceeded* EnDat error message. Compliance with the operating temperature at measuring point M1 is also required for adherence to the encoder's proper and intended use.

Information on connecting an external temperature sensor

- The external temperature sensor must comply with the following requirements as per EN 61800-5-1:
 - Voltage class A
 - Contamination level 2
 - Overvoltage category 3
- Connect only passive temperature sensors.
- The connections for the temperature sensor are galvanically connected with the encoder electronics.
- Depending on the application, the temperature sensor assembly (sensor + cable assembly) must be mounted such that it is insulated from its environment with double or reinforced insulation.
- The accuracy of the temperature measurement depends on the temperature range.
- Take into account the tolerance of the temperature sensor.
- The transmitted temperature value is not a safe value in terms of functional safety.
- The motor manufacturer is responsible for the quality and accuracy of the temperature sensor, as well as for ensuring electrical safety.
- Use a crimp connector with a suitable temperature range (e.g., up to 150 °C ID 1148157-01).

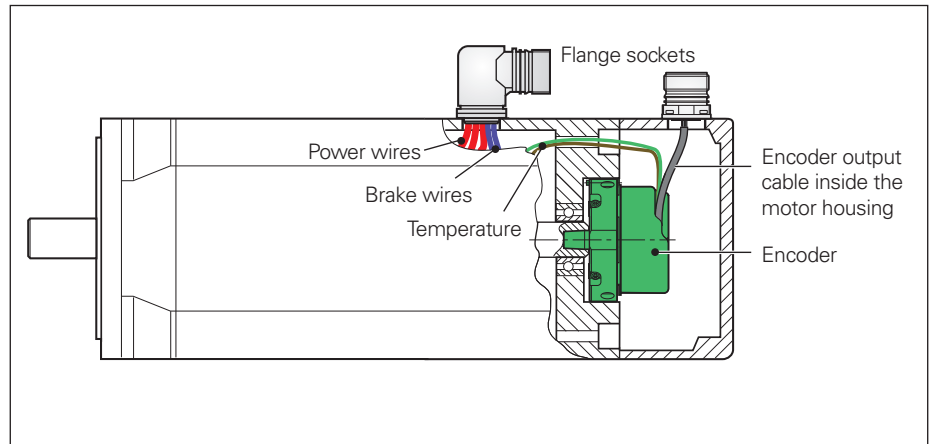

Cable configuration of the temperature wires in the motor

The accuracy of the temperature measurement depends on the sensor being used and on the temperature range.

	KTY 84-130	PT 1000
–40 °C to +80 °C	±6 K	±6 K
80.1 °C to 160 °C	±3 K	±4 K
160.1 °C to 200 °C	±6 K	±6 K

Specifications for the evaluation

Resolution	0.1 K (with KTY 84-130)
Supply voltage of sensor	3.3 V over dropping resistor $R_V = 2 \text{ k}\Omega$
Measuring current (typical)	1.2 mA at 595 Ω 1.0 mA at 990 Ω
Total delay of temperature evaluation ¹⁾	160 ms max.
Cable length ²⁾ With wire cross section of 0.16 mm ² for TPE, or 0.25 mm ² for cross-linked polyolefine	≤ 1 m

¹⁾ Filter time constants and conversion time are taken into account; the time constants / response delay of the temperature sensor and the time lag for reading via the encoder interface are not included in this.

²⁾ Limitation of the cable length due to interference; the measuring error due to the line resistance is negligible.

Connectable temperature sensors

The temperature evaluation performed within the rotary encoder is designed for a KTY 84-130 PTC thermistor. For other temperature sensors, the output value (value in additional data 1) must be converted into a temperature value.

Figure 1 illustrates the relationship between the output value and the resistance of the temperature sensor. When a KTY 84-130 is used, the temperature value equals the output value. The value has an increment of 0.1 kelvins.

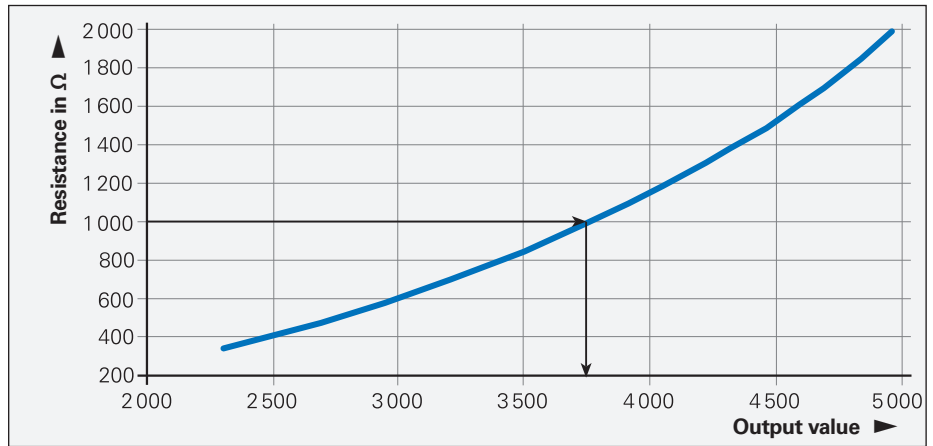

Figure 1: Relationship between the output value and resistance

Example for the KTY 84-130 temperature sensor:
 Sensor resistance = 1000 Ω → Output value (temperature value) 3751,
 which is equal to 375.1 K or 102 °C.

Figure 2 shows the relationship between the output value and the temperature value for a PT 1000. In the graph, the temperature value for the PT 1000 can be determined based on the output value.

For more information, see page 42.

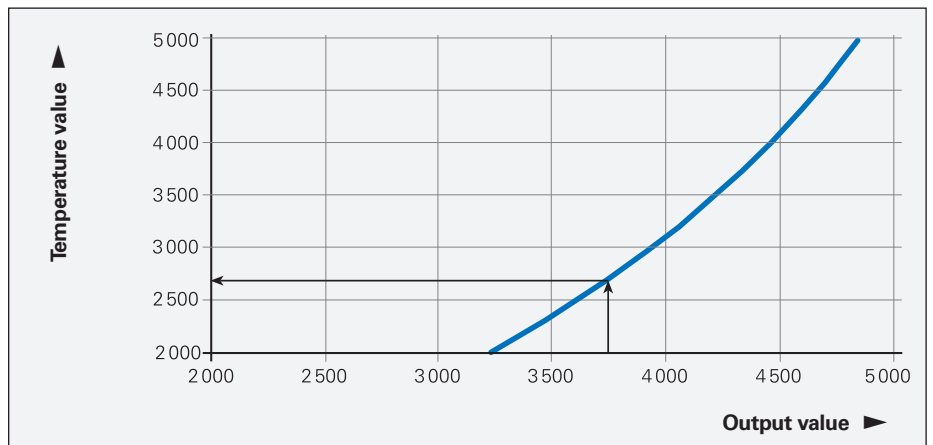

Figure 2: Relationship between the output value and temperature value using the PT 1000 as an example

Example with PT 1000 temperature sensor:
 Output value = 3751 → Temperature value = 2734 (equivalent to 0.3 °C).
 The following polynomial can be used to calculate the temperature value:

$$\text{Temperature}_{PT1000} = 1.3823 \cdot 10^{-7} \cdot A^3 - 1.2005 \cdot 10^{-3} \cdot A^2 + 4.6807 \cdot A - 5.2276 \cdot 10^3$$

A = Output value. The PT1000 polynomial is valid for: 3400 ≤ A ≤ 4810.

ECN/EQN 1100 series

Absolute rotary encoders

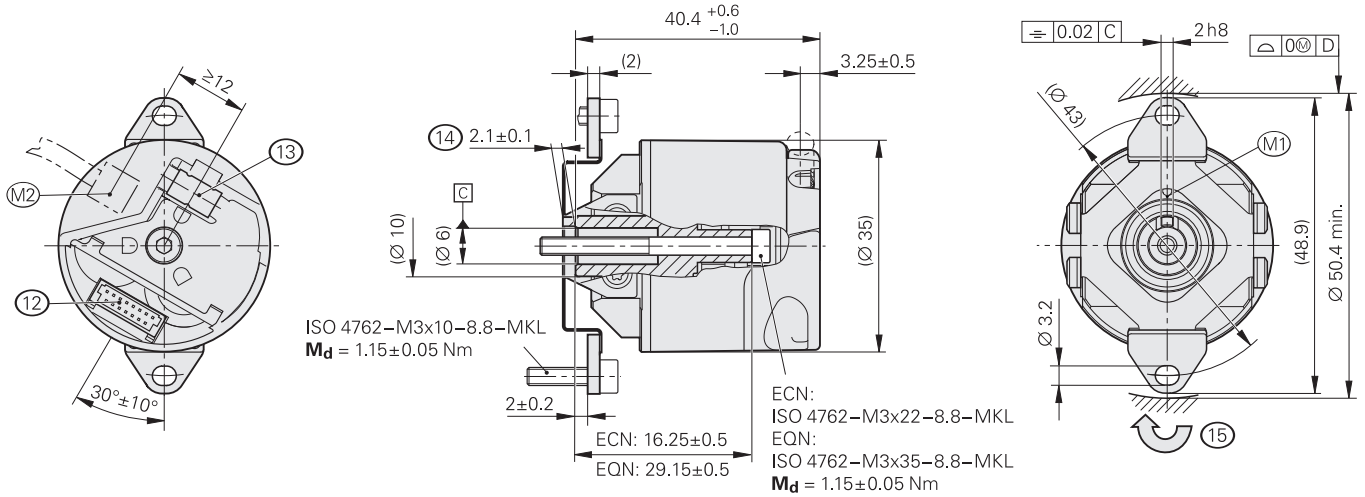

- 75A stator coupling for plane surface
- Blind hollow shaft
- Encoders available with functional safety

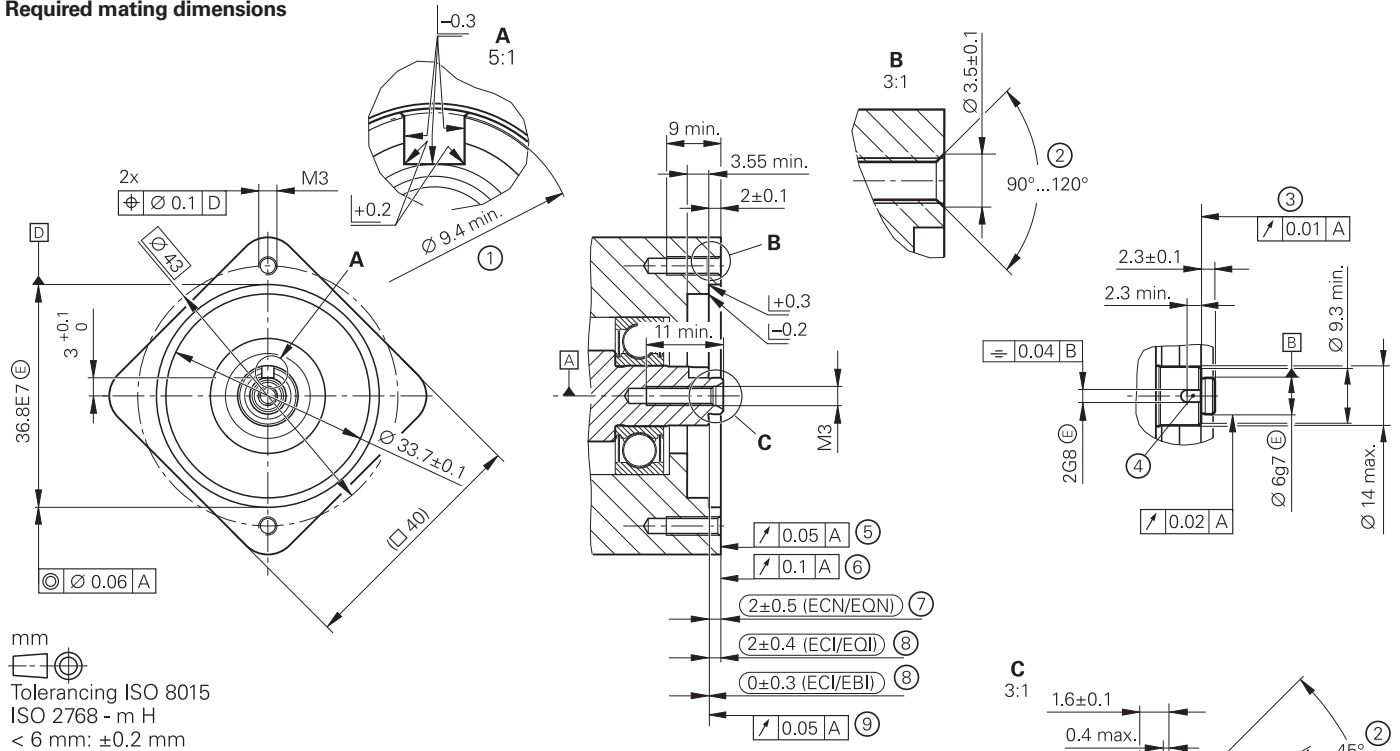

Required mating dimensions



- ▣ = Bearing of mating shaft
- M1 = Measuring point for operating temperature
- M2 = Measuring point for vibration
- 1 = Contact surface of slot
- 2 = Chamfer at start of thread is mandatory for material bonding anti-rotation lock
- 3 = Shaft surface; ensure full-surface contact!
- 4 = Slot required only for ECN/EQN and ECI/EQI, WELLA1 = 1KA
- 5 = Flange surface of ECI/EQI FS; ensure full-surface contact!
- 6 = Coupling surface of ECN/EQN
- 7 = Maximum permissible deviation between the shaft surface and coupling surface; compensation of mounting tolerances and thermal expansion, of which ±0.15 mm of dynamic axial motion is permitted
- 8 = Maximum permissible deviation between the shaft surface and flange surface; compensation of mounting tolerances and thermal expansion
- 9 = Flange surface of ECI/EBI; ensure full-surface contact!
- 10 = Undercut
- 11 = Possible centering hole
- 12 = 15-pin PCB connector
- 13 = Cable gland with crimp sleeve; diameter: 4.3 mm ±0.1 mm; length: 7 mm
- 14 = Positive-locking element. Ensure correct engagement in slot 4 (e.g., by measuring the device overhang)
- 15 = Direction of shaft rotation for ascending position values

	Absolute			
	ECN 1113	ECN 1123 ECN 1123S 	EQN 1125	EQN 1135 EQN 1135S 
Interface	EnDat 2.2	ECN 1123: EnDat 2.2 ECN 1123S: DRIVE-CLiQ	EnDat 2.2	EQN 1135: EnDat 2.2 EQN 1135S: DRIVE-CLiQ
Ordering designation	EnDat01	ECN 1123: EnDat22 ECN 1123S: DQ01	EnDat01	EQN 1135: EnDat22 EQN 1135S: DQ01
Position values per rev.	8192 (13 bits)	8388608 (23 bits)	8192 (13 bits)	8388608 (23 bits)
Revolutions	–		4096 (12 bits)	
Elec. permiss. shaft speed/ deviations ¹⁾	4000 rpm/±1 LSB 12000 rpm/±16 LSB	12000 rpm (for continuous position value)	4000 rpm/±1 LSB 12000 rpm/±16 LSB	12000 rpm (for continuous position value)
Calc. t_{cal} / clock freq. ⁴⁾	≤ 9 μs / ≤ 2 MHz	ECN 1123: ≤ 7 μs / ≤ 8 MHz	≤ 9 μs / ≤ 2 MHz	EQN 1135: ≤ 7 μs / ≤ 8 MHz
Calculation time TIME_MAX_ACTVAL ⁵⁾	–	ECN 1123S: ≤ 8 μs	–	EQN 1135S: ≤ 8 μs
Incremental signals	~ 1 V _{PP} ²⁾	–	~ 1 V _{PP} ²⁾	–
Line count	512	–	512	–
Cutoff frequency –3 dB	≥ 190 kHz	–	≥ 190 kHz	–
System accuracy	±60"			
Electrical connection	15-pin	15-pin ³⁾	15-pin	15-pin ³⁾
Supply voltage	DC 3.6 V to 14 V	ECN 1123: DC 3.6 to 14 V ECN 1123S: DC 10 to 28.8 V	DC 3.6 V to 14 V	EQN 1135: DC 3.6 to 14 V EQN 1135S: DC 10 to 28.8 V
Power consumption (max.)	3.6 V: ≤ 0.6 W 14 V: ≤ 0.7 W	ECN 1123: 3.6 V: ≤ 0.6 W 14 V: ≤ 0.7 W ECN 1123S: 10 V: ≤ 0.85 W 28.8 V: ≤ 0.9 W	3.6 V: ≤ 0.7 W 14 V: ≤ 0.8 W	EQN 1135: 3.6 V: ≤ 0.7 W 14 V: ≤ 0.8 W EQN 1135S: 10 V: ≤ 0.95 W 28.8 V: ≤ 1 W
Current consumption (typical)	5 V: 85 mA (without load)	5 V: 85 mA (without load) 24 V: 32 mA (without load)	5 V: 105 mA (without load)	5 V: 105 mA (without load) 24 V: 35 mA (without load)
Shaft	Blind hollow shaft Ø 6 mm with positive-locking element			
Mech. permiss. shaft speed n	12000 rpm			
Starting torque (typical)	0.001 Nm (at 20 °C)		0.002 Nm (at 20 °C)	
Moment of inertia of rotor	≈ 0.4 · 10 ⁻⁶ kgm ²			
Permiss. axial motion of measured shaft	±0.5 mm			
Vibration 55 Hz to 2000 Hz Shock 6 ms	≤ 200 m/s ² (EN 60068-2-6) ≤ 1000 m/s ² (EN 60068-2-27)			
Max. operating temperature	115 °C	ECN 1123: 115 °C ECN 1123S: 95 °C	115 °C	EQN 1135: 115 °C EQN 1135S: 95 °C
Min. operating temperature	–40 °C			
Protection EN 60529	IP40 (read about isolation under <i>Electrical safety</i> in the <i>Interfaces of HEIDENHAIN Encoders</i> brochure)			
Mass	≈ 0.1 kg			
ID number	803427-xx	ECN 1123: 803429-xx ECN 1123S: 1211015-xx	803428-xx	EQN 1135: 803430-xx EQN 1135S: 1211017-xx

¹⁾ Speed-dependent deviations between absolute and incremental signals

²⁾ Deviating tolerances Signal amplitude: 0.80 V_{PP} to 1.2 V_{PP} Asymmetry: 0.05
Signal ratio: 0.9 to 1.1 Phase angle: 90° elec. ±5° elec.

³⁾ With connection for temperature sensor; evaluation optimized for KTY 84-130

⁴⁾ Applies only to EnDat rotary encoders

⁵⁾ Applies only to DRIVE-CLiQ rotary encoders

Functional safety is available for ECN 1123 and EQN 1135. For dimensions and specifications, see the Product Information document.

ERN 1023

Incremental rotary encoders

- Stator coupling for plane surface
- Blind hollow shaft
- Block commutation signals

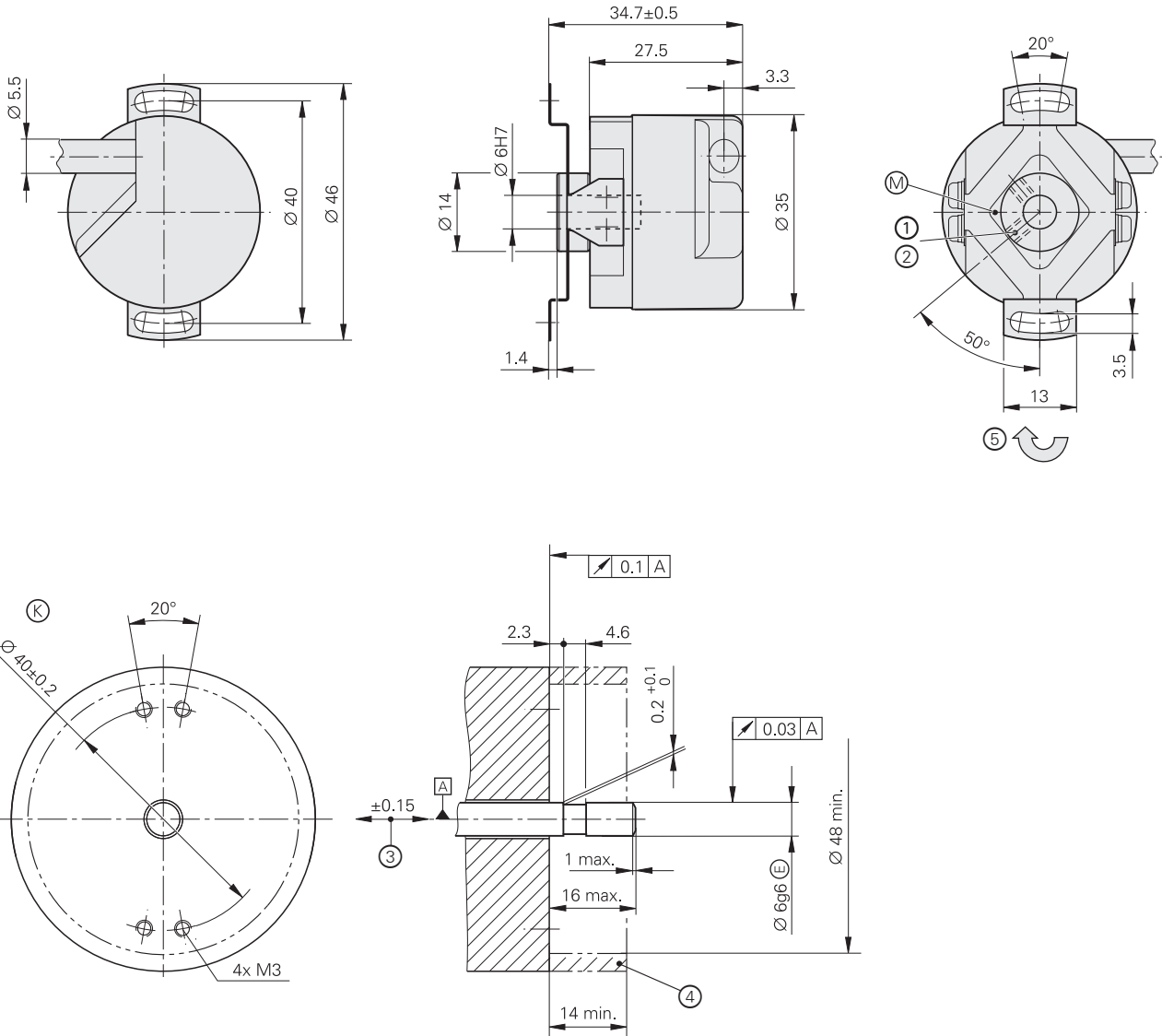
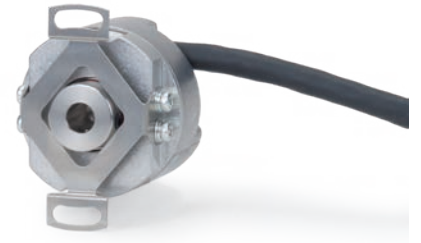

mm
 Tolerancing ISO 8015
 ISO 2768 - m H
 < 6 mm: ±0.2 mm

- ▣ = Bearing of mating shaft
- ⊙ = Required mating dimensions
- M = Measuring point for operating temperature
- 1 = Two screws in clamping ring; tightening torque: 0.6 Nm ±0.1 Nm; width A/F 1.5
- 2 = Reference mark position ±10°
- 3 = Compensation of mounting tolerances and thermal expansion; no dynamic motion permitted
- 4 = Ensure protection against contact (EN 60529)
- 5 = Direction of shaft rotation for ascending position values

ERN 1023	
Interface	□□TTL
Signal periods per rev.*	500 512 600 1000 1024 1250 2000 2048 2500 4096 5000 8192
Reference mark	One
Output frequency Edge separation <i>a</i>	≤ 300 kHz ≥ 0.41 μs
Commutation signals ¹⁾	□□TTL (3 commutation signals U, V, W)
Width*	2 x 180° (C01); 3 x 120° (C02); 4 x 90° (C03)
System accuracy	±260" ±130"
Electrical connection*	Cable (1 m , 5 m) without coupling
Supply voltage	DC 5 V ±0.5 V
Current consumption (without load)	≤ 70 mA
Shaft	Blind hollow shaft Ø 6 mm
Mech. permiss. shaft speed <i>n</i>	≤ 6000 rpm
Starting torque (typical)	0.005 Nm (at 20 °C)
Moment of inertia of rotor	0.5 · 10 ⁻⁶ kgm ²
Permiss. axial motion of measured shaft	±0.15 mm
Vibration 25 Hz to 2000 Hz Shock 6 ms	≤ 100 m/s ² (EN 60068-2-6) ≤ 1000 m/s ² (EN 60068-2-27)
Max. operating temperature	90 °C
Min. operating temperature	<i>Fixed cable:</i> -20 °C <i>Moving cable:</i> -10 °C
Protection EN 60529	IP64
Mass	≈ 0.07 kg (without cable)
ID number	684703-xx

Bold: This preferred version is available on short notice

* Please select when ordering

¹⁾ Three square-wave signals with signal periods with 90°, 120°, or 180° mech. phase shift;
see *Commutation signals for block commutation* in the *Interfaces of HEIDENHAIN Encoders* brochure

ERN 1123	
Interface	□□TTL
Signal periods per rev.*	500 512 600 1000 1024 1250 2000 2048 2500 4096 5000 8192
Reference mark	One
Output frequency Edge separation <i>a</i>	≤ 300 kHz ≥ 0.41 μs
Commutation signals ¹⁾	□□TTL (3 commutation signals U, V, W)
Width*	2 x 180° (C01); 3 x 120° (C02); 4 x 90° (C03)
System accuracy	±260" ±130"
Electrical connection	15-pin
Supply voltage	DC 5 V ±0.5 V
Current consumption (without load)	≤ 70 mA
Shaft	Hollow through shaft Ø 8 mm
Mech. permiss. shaft speed <i>n</i>	≤ 6000 rpm
Starting torque (typical)	0.005 Nm (at 20 °C)
Moment of inertia of rotor	0.5 · 10 ⁻⁶ kgm ²
Permiss. axial motion of measured shaft	±0.15 mm
Vibration 25 Hz to 2000 Hz Shock 6 ms	≤ 100 m/s ² (EN 60068-2-6) ≤ 1000 m/s ² (EN 60068-2-27)
Operating temperature	-20 °C to 90 °C
Protection EN 60529	IP00 ²⁾
Mass	≈ 0.06 kg
ID number	684702-xx

Bold: This preferred version is available on short notice

* Please select when ordering

¹⁾ Three square-wave signals with signal periods with 90°, 120°, or 180° mech. phase shift;
see *Commutation signals for block commutation* in the *Interfaces of HEIDENHAIN Encoders* brochure

²⁾ Conformity with the EMC Directive must be ensured in the complete system

ECN/EQN 1300 series

Absolute rotary encoders

- 07B stator coupling with anti-rotation element for axial mounting
- 65B tapered shaft
- Encoders available with functional safety
- Fault exclusion for rotor coupling and stator coupling as per EN 61800-5-2 possible

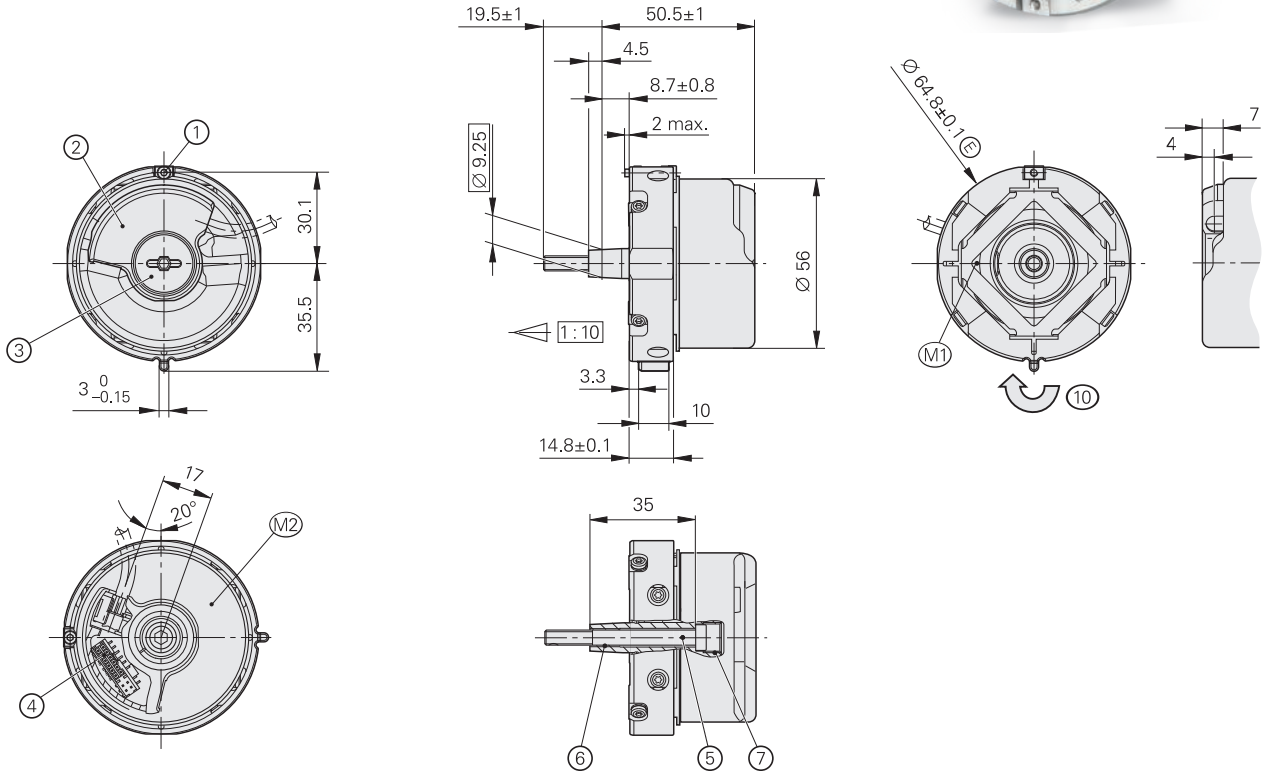

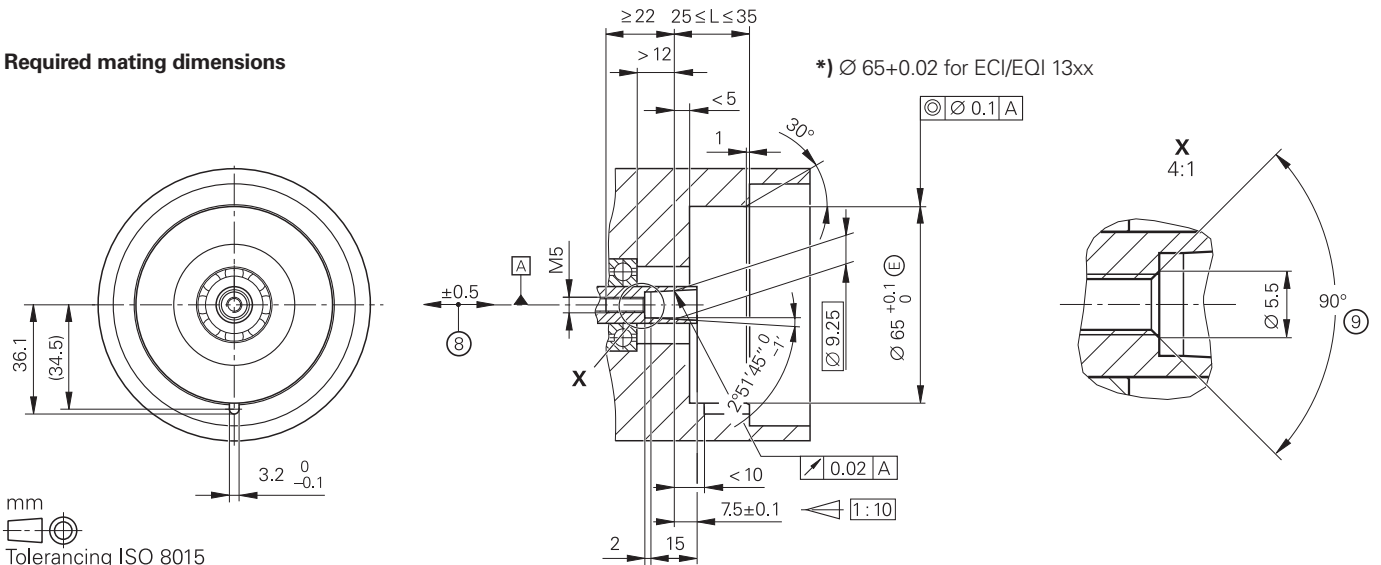

Required mating dimensions



mm
 Tolerancing ISO 8015
 ISO 2768 - m H
 ≤ 6 mm: ±0.2 mm

- ▣ = Bearing of mating shaft
- ⊕ = Required mating dimensions
- M1 = Measuring point for operating temperature
- M2 = Measuring point for vibration, see D 741714
- 1 = Clamping screw for coupling ring: width A/F 2; tightening torque: 1.25 Nm -0.2 Nm
- 2 = Die-cast cover
- 3 = Screw plug: widths A/F 3 and 4; tightening torque: 5 Nm +0.5 Nm
- 4 = 12-pin or 16-pin PCB connector
- 5 = Screw: DIN 6912 – M5x50 – 08.8 – MKL; width A/F 4; tightening torque: 5 Nm +0.5 Nm
- 6 = M6 back-off thread
- 7 = M10 back-off thread
- 8 = Compensation of mounting tolerances and thermal expansion; no dynamic motion permitted
- 9 = Chamfer at start of thread is mandatory for material bonding anti-rotation lock
- 10 = Direction of shaft rotation for ascending position values

	Absolute			
	ECN 1313	ECN 1325 	EQN 1325	EQN 1337 
Interface	EnDat 2.2			
Ordering designation	EnDat01	EnDat22	EnDat01	EnDat22
Position values per rev.	8192 (13 bits)	33 554 432 (25 bits)	8192 (13 bits)	33 554 432 (25 bits)
Revolutions	–		4096 (12 bits)	
Elec. permiss. shaft speed/ deviations ²⁾	<i>512 lines:</i> 5000 rpm/±1 LSB 12000 rpm/±100 LSB <i>2048 lines:</i> 1500 rpm/±1 LSB 12000 rpm/±50 LSB	15000 rpm (for continuous position value)	<i>512 lines:</i> 5000 rpm/±1 LSB 12000 rpm/±100 LSB <i>2048 lines:</i> 1500 rpm/±1 LSB 12000 rpm/±50 LSB	15000 rpm (for continuous position value)
Calculation time t_{cal} Clock frequency	≤ 9 μs ≤ 2 MHz	≤ 7 μs ≤ 8 MHz	≤ 9 μs ≤ 2 MHz	≤ 7 μs ≤ 8 MHz
Incremental signals	$\sim 1 V_{PP}^{1)}$	–	$\sim 1 V_{PP}^{1)}$	–
Line count*	512 2048	2048	512 2048	2048
Cutoff frequency –3 dB	<i>2048 lines:</i> ≥ 400 kHz <i>512 lines:</i> ≥ 130 kHz	–	<i>2048 lines:</i> ≥ 400 kHz <i>512 lines:</i> ≥ 130 kHz	–
System accuracy	<i>512 lines:</i> ±60"; <i>2048 lines:</i> ±20"			
Electrical connection	12-pin	16-pin with connection for temperature sensor ³⁾	12-pin	16-pin with connection for temperature sensor ³⁾
Supply voltage	DC 3.6 V to 14 V			
Power consumption (max.)	3.6 V: ≤ 0.6 W 14 V: ≤ 0.7 W		3.6 V: ≤ 0.7 W 14 V: ≤ 0.8 W	
Current consumption (typical)	5 V: 85 mA (without load)		5 V: 105 mA (without load)	
Shaft	Tapered shaft Ø 9.25 mm; taper 1:10			
Mech. permiss. shaft speed n	≤ 15000 rpm		≤ 12000 rpm	
Starting torque (typical)	0.01 Nm (at 20 °C)			
Moment of inertia of rotor	$2.6 \cdot 10^{-6} \text{ kgm}^2$			
Natural frequency f_N (typical)	1800 Hz			
Permiss. axial motion of measured shaft	±0.5 mm			
Vibration 55 Hz to 2000 Hz Shock 6 ms	≤ 300 m/s ² ⁴⁾ (EN 60068-2-6) ≤ 2000 m/s ² (EN 60068-2-27)			
Operating temperature	–40 °C to 115 °C			
Protection EN 60529	IP40 when mounted			
Mass	≈ 0.25 kg			
ID number	768295-xx	683643-xx	827039-xx	683645-xx

* Please select when ordering

¹⁾ Deviating tolerances
Signal amplitude: 0.8 V_{PP} to 1.2 V_{PP}
Asymmetry: 0.05
Amplitude ratio: 0.9 to 1.1
Phase angle: 90° elec. ±5° elec.
Signal-to-noise ratio E, F: ≥ 100 mV

²⁾ Speed-dependent deviations between absolute and incremental signals

³⁾ Evaluation optimized for KTY 84-130

⁴⁾ Valid as per standard at room temp.; the following applies at operating temps. of:
up to 100 °C: ≤ 300 m/s²;
up to 115 °C: ≤ 150 m/s²

Functional safety is available for the ECN 1325 and EQN 1337. For dimensions and specifications, see the Product Information document.

ECN/EQN 1300 S series

Absolute rotary encoders

- 07B stator coupling with anti-rotation element for axial mounting
- 65B tapered shaft
- Encoders available with functional safety
- Fault exclusion for rotor coupling and stator coupling as per EN 61800-5-2 possible

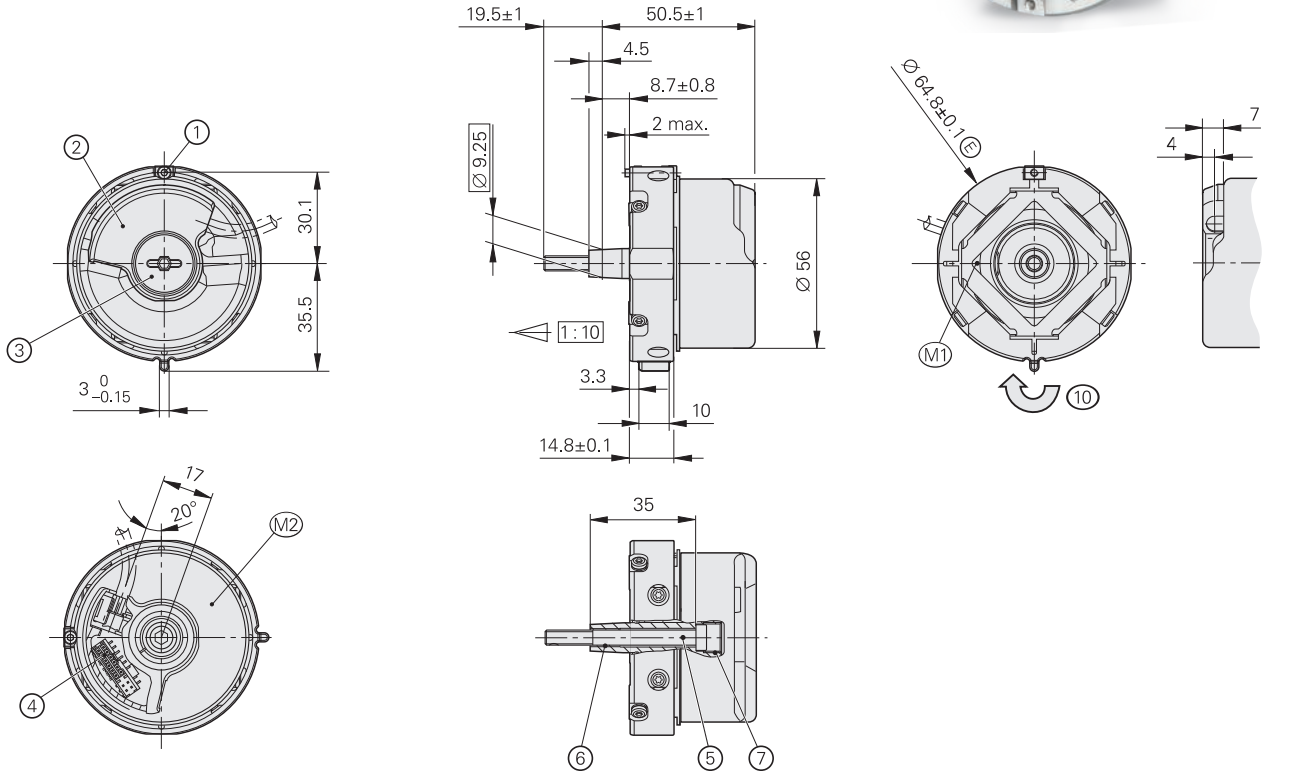

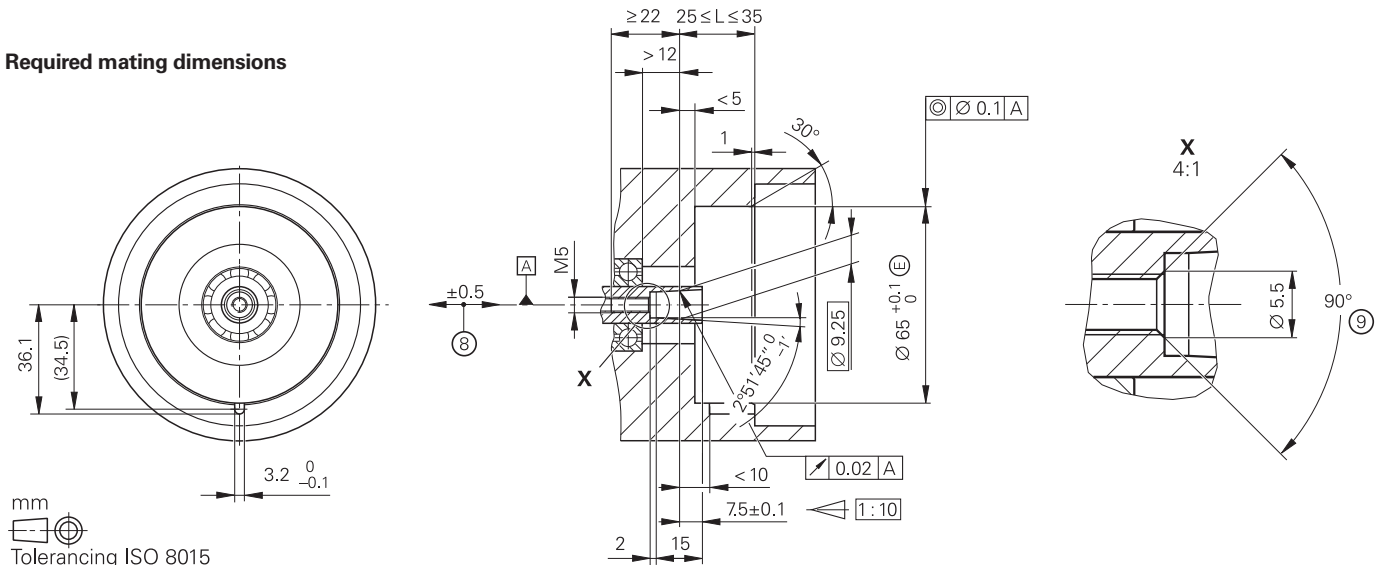

Required mating dimensions



mm

 Tolerancing ISO 8015
 ISO 2768 - m H
 ≤ 6 mm: ±0.2 mm

- ▣ = Bearing of mating shaft
- M1 = Measuring point for operating temperature
- M2 = Measuring point for vibration, see D 741714
- 1 = Clamping screw for coupling ring: width A/F 2; tightening torque: 1.25 Nm -0.2 Nm
- 2 = Die-cast cover
- 3 = Screw plug: widths A/F 3 and 4; tightening torque: 5 Nm +0.5 Nm
- 4 = 16-pin PCB connector
- 5 = Screw: DIN 6912 - M5x50 - 08.8 - MKL; width A/F 4; tightening torque: 5 Nm +0.5 Nm
- 6 = M6 back-off thread
- 7 = M10 back-off thread
- 8 = Compensation of mounting tolerances and thermal expansion; no dynamic motion permitted
- 9 = Chamfer at start of thread is mandatory for material bonding anti-rotation lock
- 10 = Direction of shaft rotation for ascending position values

	Absolute	
	ECN 1324S 	EQN 1336S 
Interface	DRIVE-CLiQ	
Ordering designation	DQ01	
Position values per rev.	16777216 (24 bits)	
Revolutions	–	4096 (12 bits)
Shaft speed	≤ 15000 rpm (at ≥ 2 position requests per revolution)	≤ 12000 rpm (at ≥ 2 position requests per revolution)
Calculation time TIME_MAX_ACTVAL	≤ 8 μs	
Incremental signals	–	
System accuracy	±20"	
Electrical connection	16-pin with connection for temperature sensor ¹⁾	
Supply voltage	DC 10 V to 28 V	
Power consumption (max.)	10 V: ≤ 0.9 W 28.8 V: ≤ 1 W	10 V: ≤ 1 W 28.8 V: ≤ 1.1 W
Current consumption (typical)	24 V: 38 mA (without load)	24 V: 43 mA (without load)
Shaft	Tapered shaft Ø 9.25 mm; taper 1:10	
Starting torque (typical)	0.01 Nm (at 20 °C)	
Moment of inertia of rotor	2.6 · 10 ⁻⁶ kgm ²	
Natural frequency f _N (typical)	1800 Hz	
Permiss. axial motion of measured shaft	±0.5 mm	
Vibration 55 Hz to 2000 Hz Shock 6 ms	≤ 300 m/s ² (EN 60068-2-6) ≤ 2000 m/s ² (EN 60068-2-27)	
Operating temperature	–30 °C to 100 °C	
Protection EN 60529	IP40 when mounted	
Mass	≈ 0.25 kg	
ID number	1042274-xx	1042276-xx

¹⁾ Evaluation optimized for KTY 84-130

Functional safety is available for ECN 1324S and EQN 1336 S. For dimensions and specifications, see the Product Information document.

DRIVE-CLiQ is a registered trademark of Siemens AG.

ECN/EQN 400 series

Absolute rotary encoders

- 07B stator coupling with anti-rotation element for axial mounting
- 65B tapered shaft
- Encoders available with functional safety
- Fault exclusion for rotor coupling and stator coupling as per EN 61800-5-2 possible

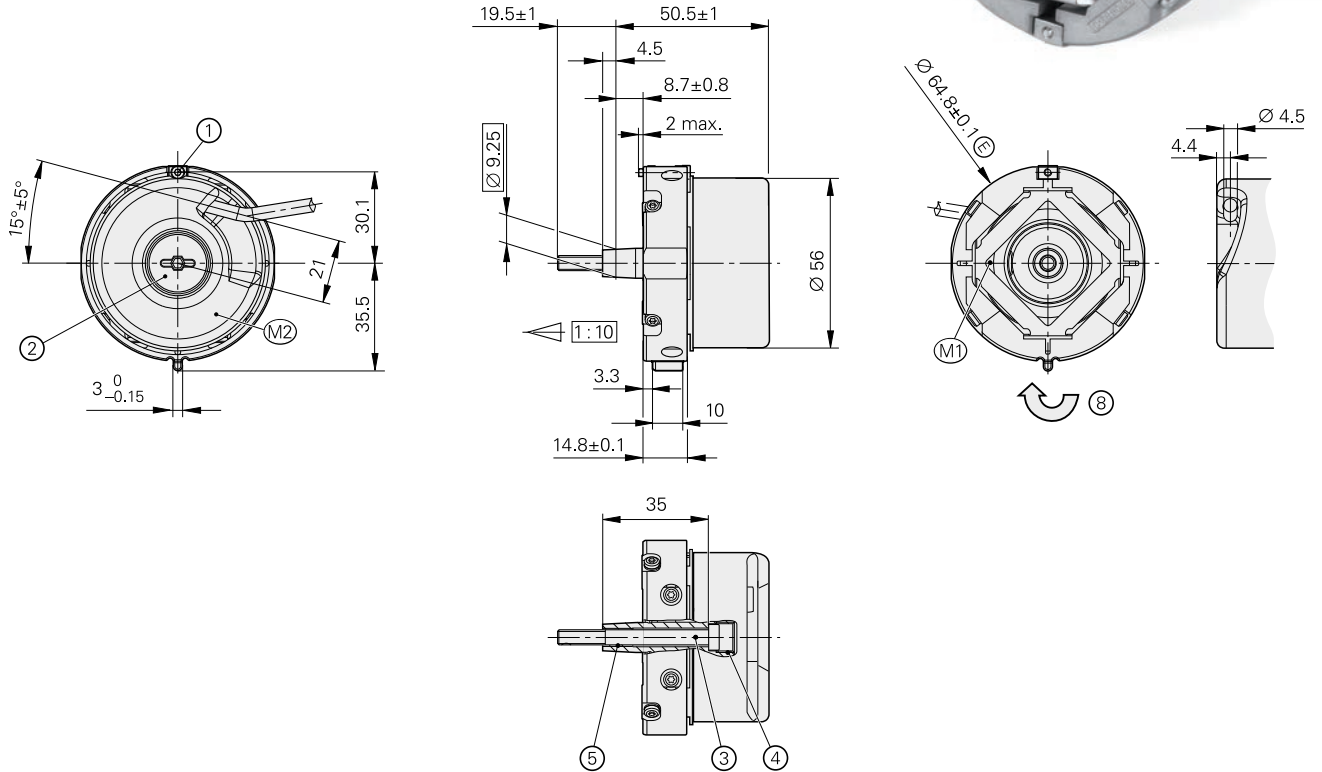
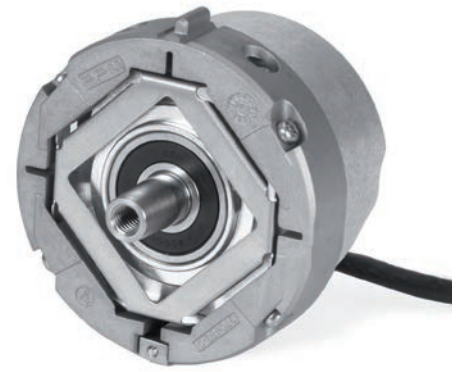

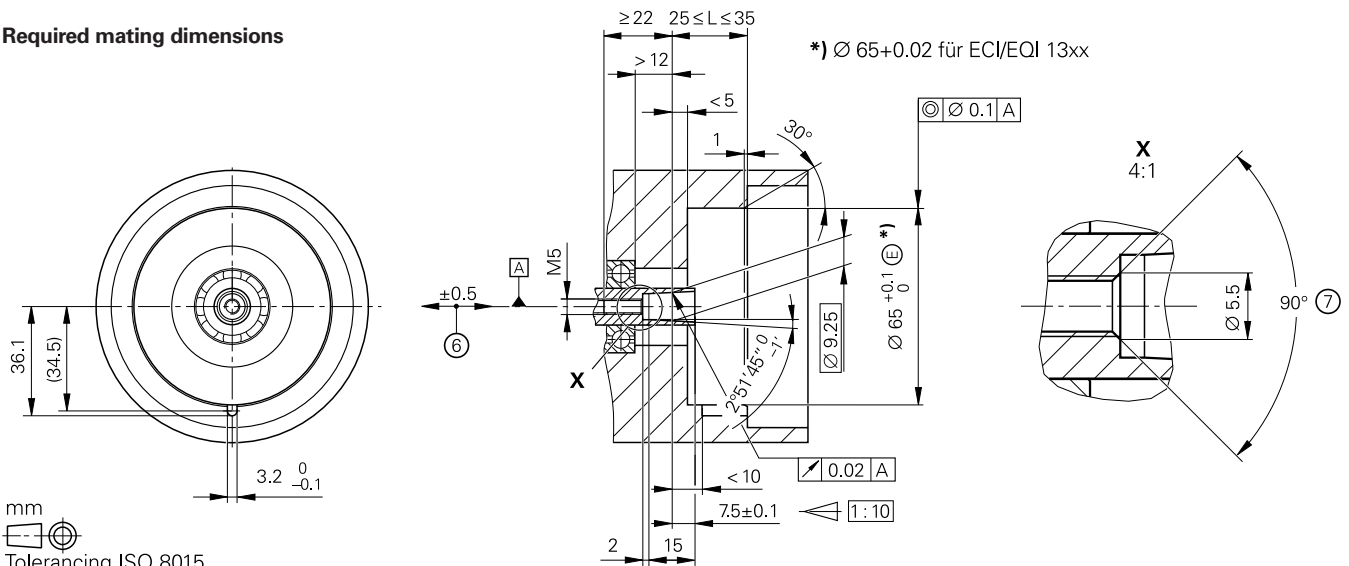

Required mating dimensions



mm
 Tolerancing ISO 8015
 ISO 2768 - m H
 < 6 mm: ± 0.2 mm

- ☐ = Bearing of mating shaft
- M1 = Measuring point for operating temperature
- M2 = Measuring point for vibration, see D 741714
- 1 = Clamping screw for coupling ring: width A/F 2; tightening torque: $1.25 \text{ Nm} - 0.2 \text{ Nm}$
- 2 = Screw plug: widths A/F 3 and 4; tightening torque: $5 \text{ Nm} + 0.5 \text{ Nm}$
- 3 = Screw: DIN 6912 - M5x50 - 08.8 - MKL; width A/F 4; tightening torque: $5 \text{ Nm} + 0.5 \text{ Nm}$
- 4 = M10 back-off thread
- 5 = M6 back-off thread
- 6 = Compensation of mounting tolerances and thermal expansion; no dynamic motion permitted
- 7 = Chamfer at start of thread is mandatory for material bonding anti-rotation lock
- 8 = Direction of shaft rotation for ascending position values

	Absolute			
	ECN 413	ECN 425 	EQN 425	EQN 437 
Interface	EnDat 2.2			
Ordering designation	EnDat01	EnDat22	EnDat01	EnDat22
Position values per rev.	8192 (13 bits)	33554432 (25 bits)	8192 (13 bits)	33554432 (25 bits)
Revolutions	–		4096 (12 bits)	
Elec. permiss. shaft speed/ deviations ²⁾	1500 rpm/±1 LSB 12000 rpm/±50 LSB	15000 rpm (for continuous position value)	1500 rpm/±1 LSB 12000 rpm/±50 LSB	15000 rpm (for continuous position value)
Calculation time t_{cal} Clock frequency	≤ 9 μs ≤ 2 MHz	≤ 7 μs ≤ 16 MHz	≤ 9 μs ≤ 2 MHz	≤ 7 μs ≤ 16 MHz
Incremental signals	~ 1 V _{PP} ¹⁾	–	~ 1 V _{PP} ¹⁾	–
Line count	2048			
Cutoff frequency –3 dB	≥ 400 kHz	–	≥ 400 kHz	–
System accuracy	±20"			
Electrical connection*	Cable (5 m) with or without M23 coupling	Cable (5 m) with M12 coupling	Cable (5 m) with or without M23 coupling	Cable (5 m) with M12 coupling
Supply voltage	DC 3.6 V to 14 V			
Power consumption (max.)	3.6 V: ≤ 0.6 W 14 V: ≤ 0.7 W		3.6 V: ≤ 0.7 W 14 V: ≤ 0.8 W	
Current consumption (typical)	5 V: 85 mA (without load)		5 V: 105 mA (without load)	
Shaft	Tapered shaft Ø 9.25 mm; taper 1:10			
Mech. permiss. shaft speed n	≤ 15000 rpm		≤ 12000 rpm	
Starting torque (typical)	0.01 Nm (at 20 °C)			
Moment of inertia of rotor	2.6 · 10 ⁻⁶ kgm ²			
Natural frequency f_N (typical)	1800 Hz			
Permiss. axial motion of measured shaft	±0.5 mm			
Vibration 55 Hz to 2000 Hz Shock 6 ms	≤ 300 m/s ² (EN 60068-2-6) ≤ 2000 m/s ² (EN 60068-2-27)			
Max. operating temperature	100 °C			
Min. operating temp.	<i>Fixed cable:</i> –40 °C <i>Moving cable:</i> –10 °C			
Protection EN 60529	IP64 when mounted			
Mass	≈ 0.25 kg			
ID number	1065932-xx	683644-xx	1109258-xx	683646-xx

* Please select when ordering

¹⁾ Deviating tolerances
Signal amplitude: 0.8 V_{PP} to 1.2 V_{PP}
Asymmetry: 0.05
Amplitude ratio: 0.9 to 1.1
Phase angle: 90° elec. ±5° elec.

²⁾ Speed-dependent deviations between absolute and incremental signals

Functional safety is available for ECN 425 and EQN 437. For dimensions and specifications, see the Product Information document.

ERN 1300 series

Incremental rotary encoders

- 06 stator coupling for axial mounting
- 65B tapered shaft

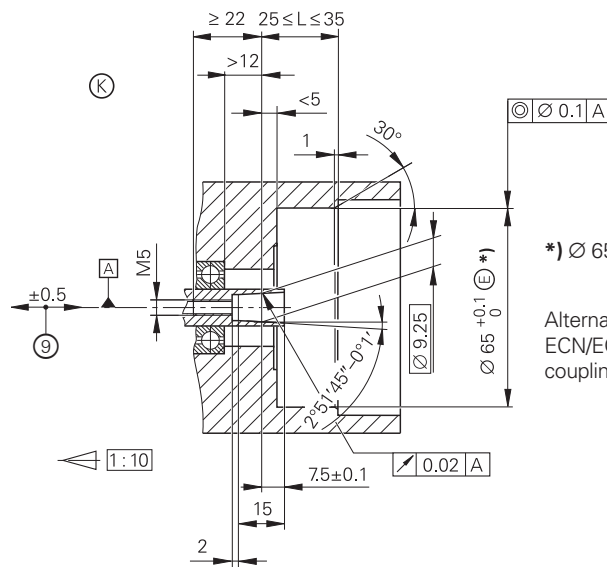
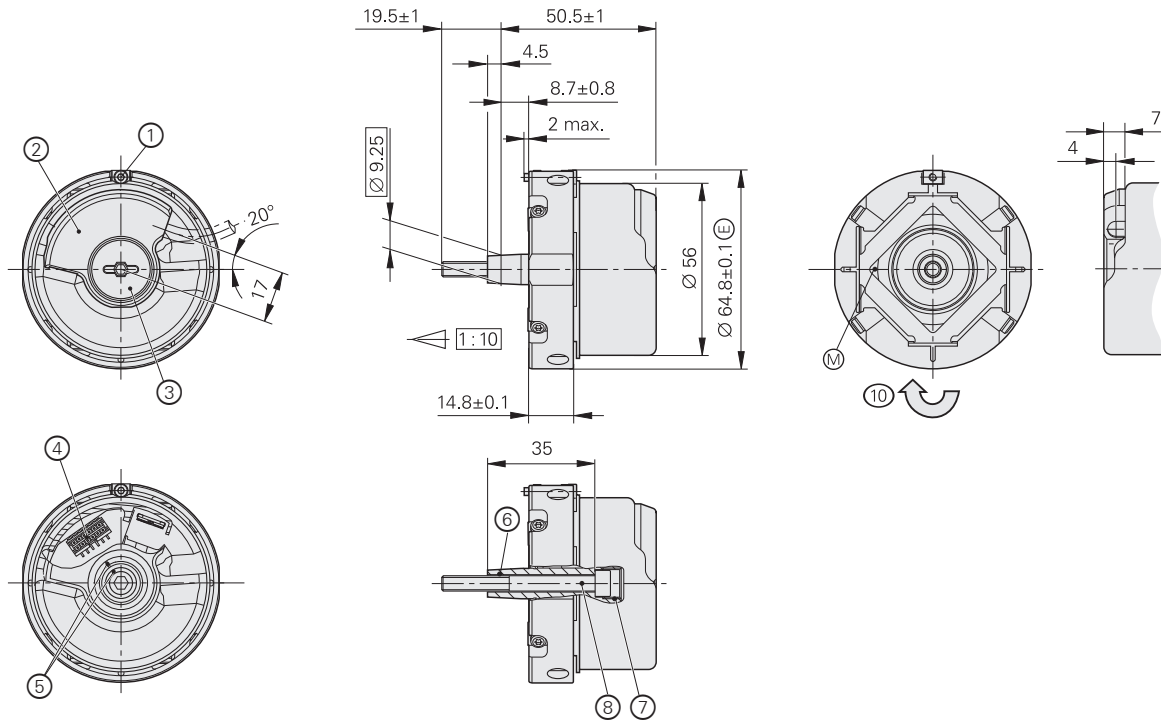

*) $\varnothing 65+0.02$ for ECI/EQI 13xx

Alternative:
ECN/EQN 1300 mating dimensions with slot for stator coupling for the anti-rotation element are also usable.

mm

 Tolerancing ISO 8015
 ISO 2768 - m H
 < 6 mm: ± 0.2 mm

- ▣ = Bearing of mating shaft
- ⊙ = Required mating dimensions
- M = Measuring point for operating temperature
- 1 = Clamping screw for coupling ring: width A/F 2; tightening torque: 1.25 Nm -0.2 Nm
- 2 = Die-cast cover
- 3 = Screw plug: widths A/F 3 and 4; tightening torque: 5 Nm $+0.5$ Nm
- 4 = 12-pin, 14-pin, or 16-pin PCB connector
- 5 = Reference mark position on shaft and cap
- 6 = M6 back-off thread
- 7 = M10 back-off thread
- 8 = Self-locking screw: DIN 6912 M5x50; width A/F 4; tightening torque: 5 Nm $+0.5$ Nm
- 9 = Compensation of mounting tolerances and thermal expansion; no dynamic motion permitted
- 10 = Direction of shaft rotation for ascending position values

	Incremental				
	ERN 1321	ERN 1381	ERN 1387	ERN 1326	
Interface	□□TTL	~ 1 V _{PP} ¹⁾		□□TTL	
Line count*/ System accuracy	1024/±64" 2048/±32" 4096/±16"	512/±60" 2048/±20" 4096/±16"	2048/±20"	1024/±64" 2048/±32" 4096/±16"	8192/±16" ⁵⁾
Reference mark	One				
Output frequency	≤ 300 kHz	–	–	≤ 300 kHz	≤ 150 kHz
Edge separation <i>a</i>	≥ 0.35 μs	–	–	≥ 0.35 μs	≥ 0.22 μs
Cutoff frequency –3 dB	–	≥ 210 kHz	–	–	–
Commutation signals	–		~ 1 V _{PP} ¹⁾	□□TTL	
Width*	–		Z1 track ²⁾	3 x 120°; 4 x 90° ³⁾	
Electrical connection	12-pin		14-pin	16-pin	
Supply voltage	DC 5 V ±0.5 V		DC 5 V ±0.25 V	DC 5 V ±0.5 V	
Current consumption (without load)	≤ 120 mA		≤ 130 mA	≤ 150 mA	
Shaft	Tapered shaft Ø 9.25 mm; taper 1:10				
Mech. permiss. shaft speed <i>n</i>	≤ 15000 rpm				
Starting torque (typical)	0.01 Nm (at 20 °C)				
Moment of inertia of rotor	2.6 · 10 ⁻⁶ kgm ²				
Natural frequency <i>f_N</i> (typical)	1800 Hz				
Permiss. axial motion of measured shaft	±0.5 mm				
Vibration 55 Hz to 2000 Hz Shock 6 ms	≤ 300 m/s ² ⁴⁾ (EN 60068-2-6) ≤ 2000 m/s ² (EN 60068-2-27)				
Max. operating temperature	120 °C	120 °C 4096 lines: 80 °C	120 °C		
Min. operating temp.	–40 °C				
Protection EN 60529	IP40 when mounted				
Mass	≈ 0.25 kg				
ID number	385423-xx	534118-xx	749144-xx	574485-xx	

* Please select when ordering

¹⁾ Deviating tolerances
Signal amplitude: 0.8 V_{PP} to 1.2 V_{PP}
Asymmetry: 0.05
Amplitude ratio: 0.9 to 1.1
Phase angle: 90° elec. ±5° elec.
Signal-to-noise ratio E, F: 100 mV

²⁾ One sine and one cosine signal per revolution; see the *Interfaces of HEIDENHAIN Encoders* brochure

³⁾ Three square-wave signals with signal periods with 90° or 120° mech. phase shift;
see the *Interfaces of HEIDENHAIN Encoders* brochures

⁴⁾ Valid as per standard at room temp.; at operating temps. of up to 100 °C: ≤ 300 m/s²;
up to 120 °C: ≤ 150 m/s²

⁵⁾ Via integrated signal doubling

EQN/ERN 400 series

Absolute and incremental rotary encoders

- Torque support
- Blind hollow shaft
- Replacement for Siemens 1XP8000

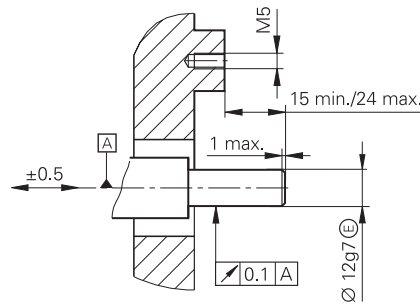
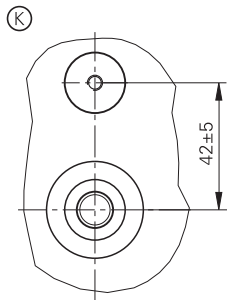
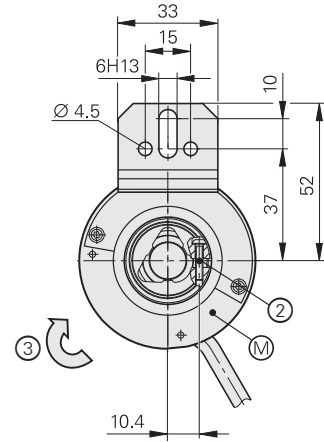
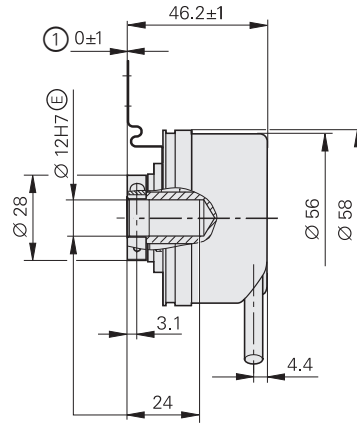
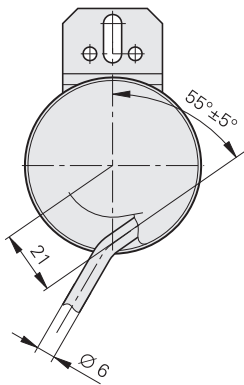

mm



Tolerancing ISO 8015

ISO 2768 - m H

< 6 mm: ±0.2 mm

Siemens model	Replacement model	ID	Design
1XP8012-10	ERN 430 ¹⁾	HTL	Cable (0.8 m) with 12-pin M23 mounted coupling with central fastening
1XP8032-10	ERN 430	HTL	
1XP8012-20	ERN 420 ¹⁾	TTL	
1XP8032-20	ERN 420	TTL	Cable (1 m) with 17-pin M23 coupling
1XP8014-10	EQN 425 ¹⁾	EnDat	
1XP8024-10	EQN 425	EnDat	
1XP8014-20	EQN 425 ¹⁾	SSI	
1XP8024-20	EQN 425	SSI	

¹⁾ Original Siemens encoder has a 17-pin M23 flange socket

⊠ = Bearing of mating shaft





⊙ = Required mating dimensions

M = Measuring point for operating temperature

1 = Distance from clamping ring to coupling

2 = Clamping screw with X8 hexalobular socket: tightening torque: 1.1 Nm ±0.1 Nm

3 = Direction of shaft rotation for ascending position values

	Absolute		Incremental	
	EQN 425		ERN 420	ERN 430
Interface*	EnDat 2.2	SSI		
Ordering designation	EnDat01	SSI41r1	–	
Position values per rev.	8192 (13 bits)		–	
Revolutions	4096		–	
Code	Pure binary	Gray	–	
Elec. permiss. shaft speed deviations ¹⁾	≤ 1500/10000 rpm ±1 LSB/±50 LSB	≤ 12000 rpm ±12 LSB	–	
Calculation time t_{cal} Clock frequency	≤ 9 μs ≤ 2 MHz	≤ 5 μs –	–	
Incremental signals	 1 V _{PP} ²⁾			
Line count	2048	512	1024	
Cutoff frequency –3 dB Output frequency Edge separation a	≥ 400 kHz – –	≥ 130 kHz – –	– ≤ 300 kHz ≥ 0.39 μs	
System accuracy	±20"	±60"	1/20 of grating period	
Electrical connection	Cable (1 m) with M23 coupling		Cable (0.8 m) with mounted coupling and central fastening	
Supply voltage	DC 3.6 V to 14 V	DC 10 V to 30 V	DC 5 V ±0.5 V	DC 10 V to 30 V
Power consumption (max.)	3.6 V: ≤ 0.7 W 14 V: ≤ 0.8 W	10 V: ≤ 0.75 W 30 V: ≤ 1.1 W	–	
Current consumption (typical, without load)	5 V: 105 mA	5 V: 120 mA 24 V: 28 mA	≤ 120 mA	≤ 150 mA
Shaft	Blind hollow shaft Ø 12 mm			
Mech. permiss. shaft speed n	≤ 6000 rpm			
Starting torque (typical)	0.05 Nm at 20 °C			
Moment of inertia of rotor	≤ 4.6 · 10 ⁻⁶ kgm ²			
Permiss. axial motion of measured shaft	±0.5 mm			
Vibration 55 Hz to 2000 Hz Shock 6 ms	≤ 300 m/s ² (EN 60068-2-6) ≤ 1000 m/s ² (EN 60068-2-27)			
Max. operating temperature	100 °C			
Min. operating temperature	Fixed cable: –40 °C Moving cable: –10 °C			
Protection EN 60529	IP66			
Mass	≈ 0.3 kg			
ID number	649989-xx	649990-xx	597330-xx	597331-xx

* Please select when ordering

¹⁾ Speed-dependent deviations between absolute value and incremental signal

²⁾ Deviating tolerances: signal amplitudes: 0.8 V_{PP} to 1.2 V_{PP}

ERN 401 series

Incremental rotary encoders

- Stator coupling via fastening clips
- Blind hollow shaft
- Replacement for Siemens 1XP8000
- Includes installation kit with housing

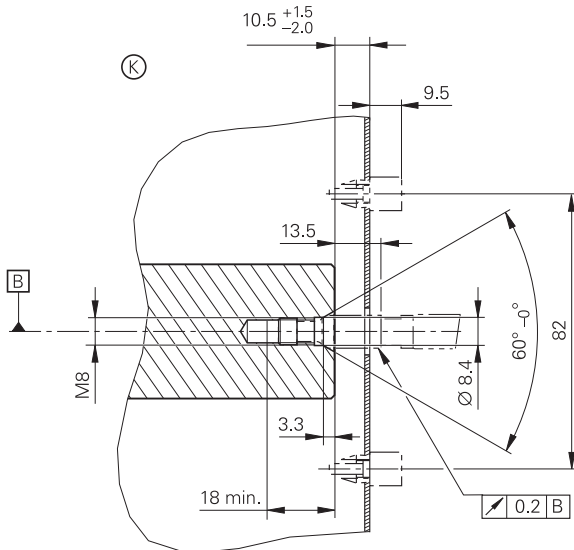
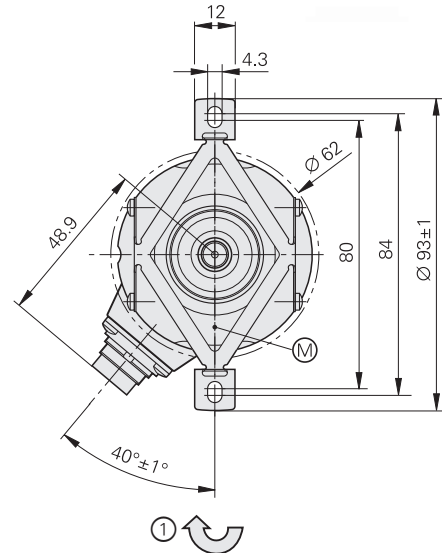
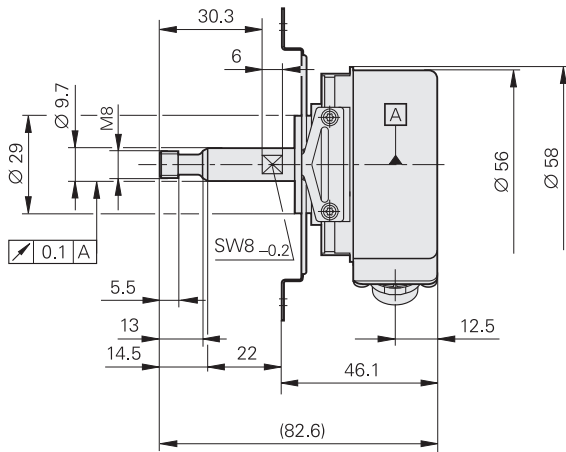
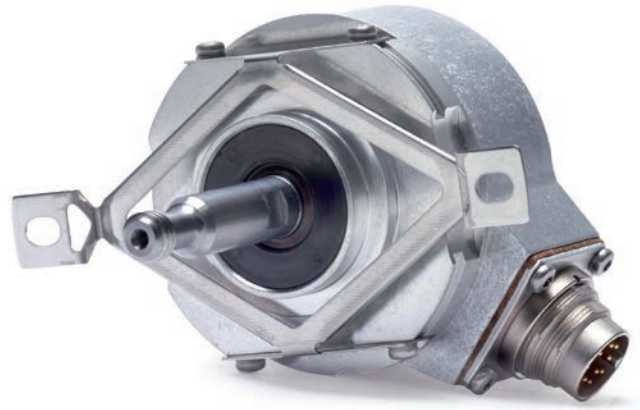

mm
 Tolerancing ISO 8015
 ISO 2768 - m H
 < 6 mm: ±0.2 mm

- ▣ = Encoder bearing
- ▣ = Bearing of mating shaft
- ⊙ = Required mating dimensions
- M = Measuring point for operating temperature
- 1 = Direction of shaft rotation for ascending position values

Siemens model	Replacement model	ID
1XP8001-2	ERN 421	538724-71
1XP8001-1	ERN 431	538725-02

	Incremental	
	ERN 421	ERN 431
Interface	□□TTL	□□HTL
Line count	1024	
Reference mark	One	
Output frequency Edge separation <i>a</i>	≤ 300 kHz ≥ 0.39 μs	
System accuracy	1/20 of grating period	
Electrical connection	M16 flange socket (female)	
Supply voltage	DC 5 V ±0.5 V	DC 10 V to 30 V
Current consumption without load	≤ 120 mA	≤ 150 mA
Shaft	Solid shaft with M8 external thread, 60° centering taper	
Mech. permiss. shaft speed <i>n</i> ¹⁾	≤ 6000 rpm	
Starting torque (typical)	0.025 Nm (at 20 °C)	
Moment of inertia of rotor	≤ 4.3 · 10 ⁻⁶ kgm ²	
Permiss. axial motion of measured shaft	±1 mm	
Vibration 55 Hz to 2000 Hz Shock 6 ms	≤ 100 m/s ² (EN 60068-2-6); higher values upon request ≤ 1000 m/s ² (EN 60068-2-27)	
Operating temperature	-40 °C to 100 °C	
Protection EN 60529	IP66	
Mass	≈ 0.3 kg	
ID number	538724-xx	538725-xx

¹⁾ For the relationship of operating temperature to shaft speed and supply voltage, see *General mechanical information*

ECI/EQI 1100 series

Absolute rotary encoders

- Flange for axial mounting
- Blind hollow shaft
- Without integral bearing

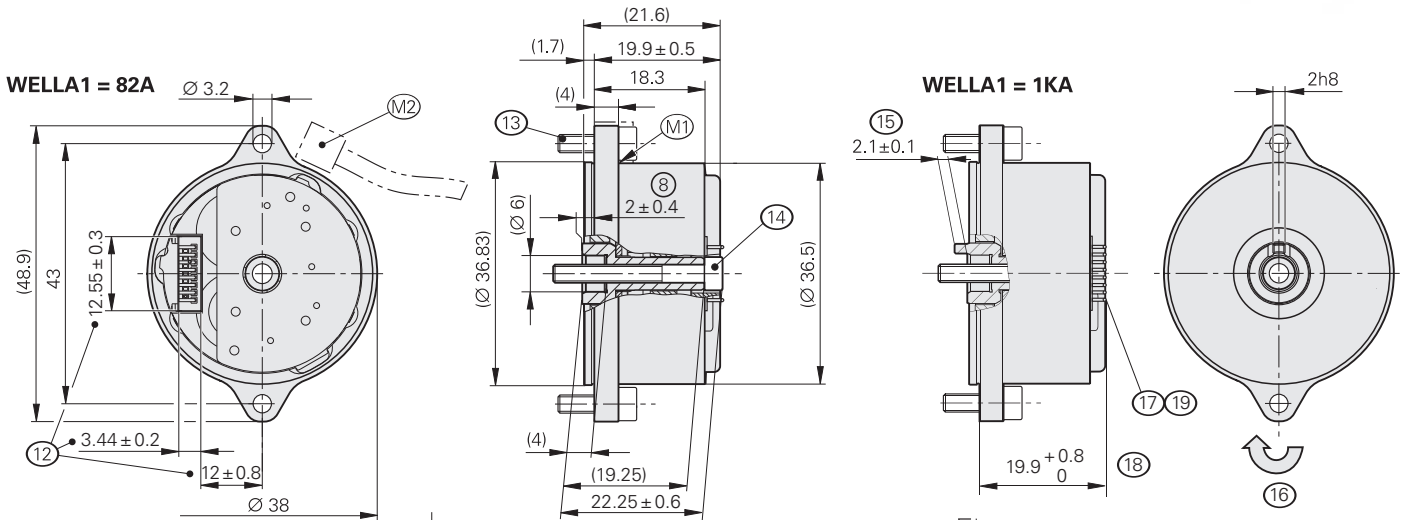

Required mating dimensions

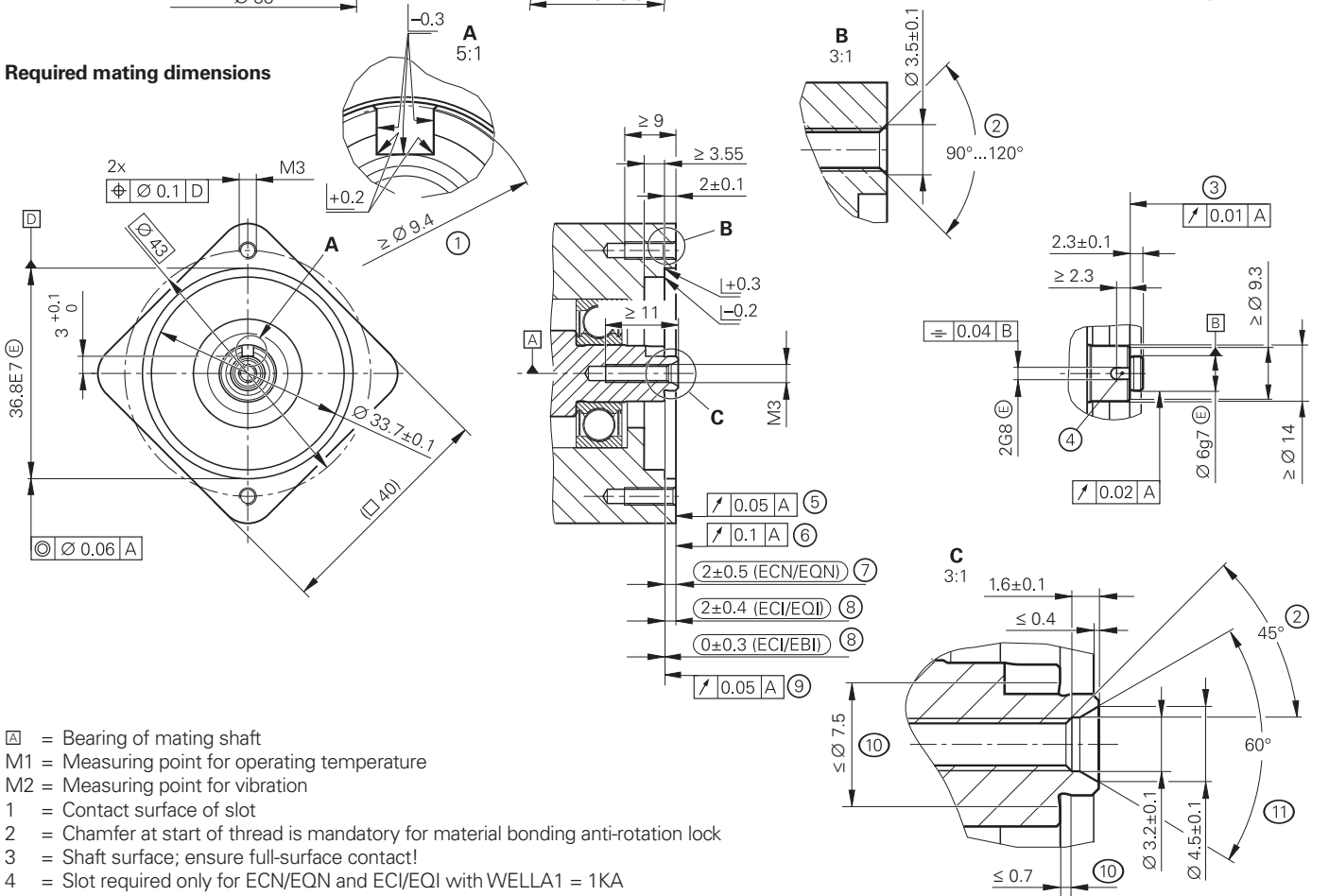

□ = Bearing of mating shaft

M1 = Measuring point for operating temperature

M2 = Measuring point for vibration

1 = Contact surface of slot

2 = Chamfer at start of thread is mandatory for material bonding anti-rotation lock

3 = Shaft surface; ensure full-surface contact!

4 = Slot required only for ECN/EQN and ECI/EQI with WELLA1 = 1KA

5 = Flange surface of ECI/EQI; ensure full-surface contact!

6 = Coupling surface of ECN/EQN

7 = Maximum permissible deviation between the shaft surface and coupling surface; compensation of mounting tolerances and thermal expansion, of which ± 0.15 mm of dynamic axial motion is permitted (ECN/EQN)

8 = Maximum permissible deviation between the shaft surface and flange surface; compensation of mounting tolerances and thermal expansion; dynamic motion permitted over entire range (ECI/EBI/EQI)

9 = Flange surface of ECI/EBI; ensure full-surface contact!

10 = Undercut

11 = Possible centering hole

12 = Distance to cover; note the opening for header, header connector, and wires

13 = Screw: ISO 4762 – M3x10 – 8.8 – MKL; tightening torque: 1 Nm \pm 0.1 Nm

14 = Screw: ISO: 4762 – M3x25 – 8.8 – MKL; tightening torque: 1 Nm \pm 0.1 Nm

15 = Positive-locking element Ensure correct engagement in slot (e.g., by measuring the device overhang)

16 = Direction of shaft rotation for ascending position values

17 = 15-pin header

18 = Dimension for JH standard cable

19 = Ensure installation space for cable



mm



Tolerancing ISO 8015

ISO 2768 - m H

≤ 6 mm: ± 0.2 mm

	Absolut – Singletum		Absolut – Multitum	
	ECI 1119 		EQI 1131 	
Interface	EnDat 2.2			
Ordering designation	EnDat22			
Position values per rev.	524288 (19 bits)			
Revolutions	–		4096 (12 bits)	
Calculation time t_{cal} Clock frequency	$\leq 5 \mu s$ $\leq 16 \text{ MHz}$			
System accuracy	$\pm 120''$			
Electrical connection	15-pin (with connection for external temperature sensor) ¹⁾			
Supply voltage	DC 3.6 V to 14 V			
Power consumption (max.)	3.6 V: $\leq 0.65 \text{ W}$ 14 V: $\leq 0.7 \text{ W}$		3.6 V: $\leq 0.75 \text{ W}$ 14 V: $\leq 0.85 \text{ W}$	
Current consumption (typical)	5 V: 95 mA (without load)		5 V: 115 mA (without load)	
Shaft*	Blind hollow shaft for axial clamping $\varnothing 6 \text{ mm}$ without positive-locking element (82A) or with positive-locking element (1KA)			
Shaft speed	$\leq 15000 \text{ rpm}$		$\leq 12000 \text{ rpm}$	
Moment of inertia of rotor	$0.2 \cdot 10^{-6} \text{ kgm}^2$			
Permiss. axial motion of measured shaft	$\pm 0.4 \text{ mm}$			
Vibration 55 Hz to 2000 Hz ²⁾ Shock 6 ms	Stator: $\leq 400 \text{ m/s}^2$; Rotor: $\leq 600 \text{ m/s}^2$ (EN 60068-2-6) $\leq 2000 \text{ m/s}^2$ (EN 60068-2-27)			
Operating temperature	$-40 \text{ }^\circ\text{C}$ to $100 \text{ }^\circ\text{C}$			
Trigger threshold of temperature exceedance error message	125 $^\circ\text{C}$ (measuring accuracy of the internal temperature sensor: $\pm 1 \text{ K}$)			
Protection EN 60529	IP00 when mounted ³⁾			
Mass	$\approx 0.04 \text{ kg}$			
ID number	1164809-xx		1164811-xx	

* Please select when ordering

Functional safety is available. For dimensions and specifications, see the Product Information document.

¹⁾ Evaluation optimized for KTY 84-130 temperature sensor

²⁾ At 10 Hz to 55 Hz with constant amplitude

³⁾ See *Electrical safety* under *General electrical information* in the *Interfaces of HEIDENHAIN Encoders* brochure; conformity with the EMC Directive must be ensured in the complete system

ECI/EQI 1100 series

Absolute rotary encoders

- 70F synchro flange for axial mounting
- 82A blind hollow shaft
- Without integral bearing
- Mounting-compatible with ECN/EQN 1100 optical rotary encoders and the ECI/EBI/EQI 1100 inductive series

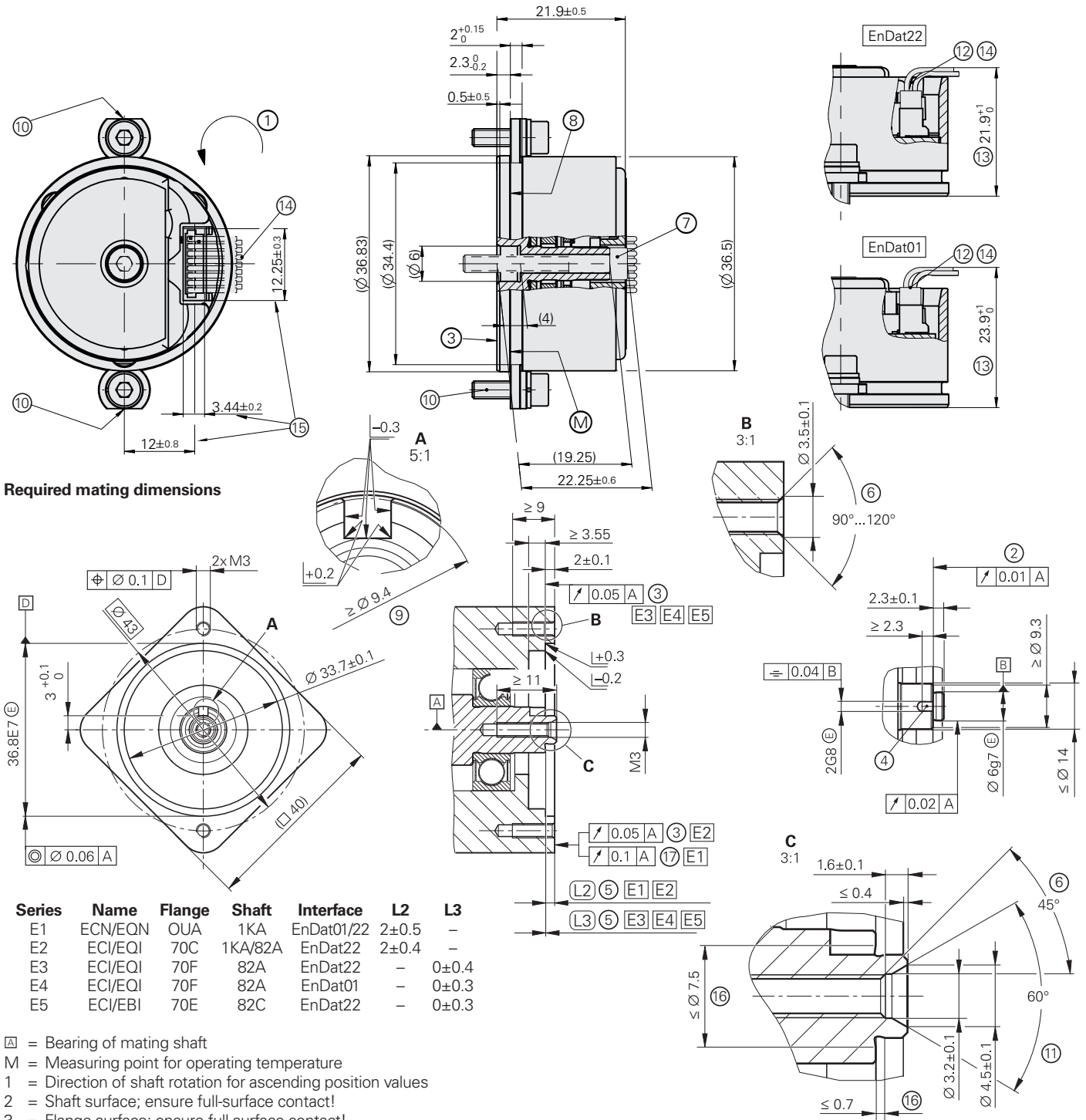

Required mating dimensions

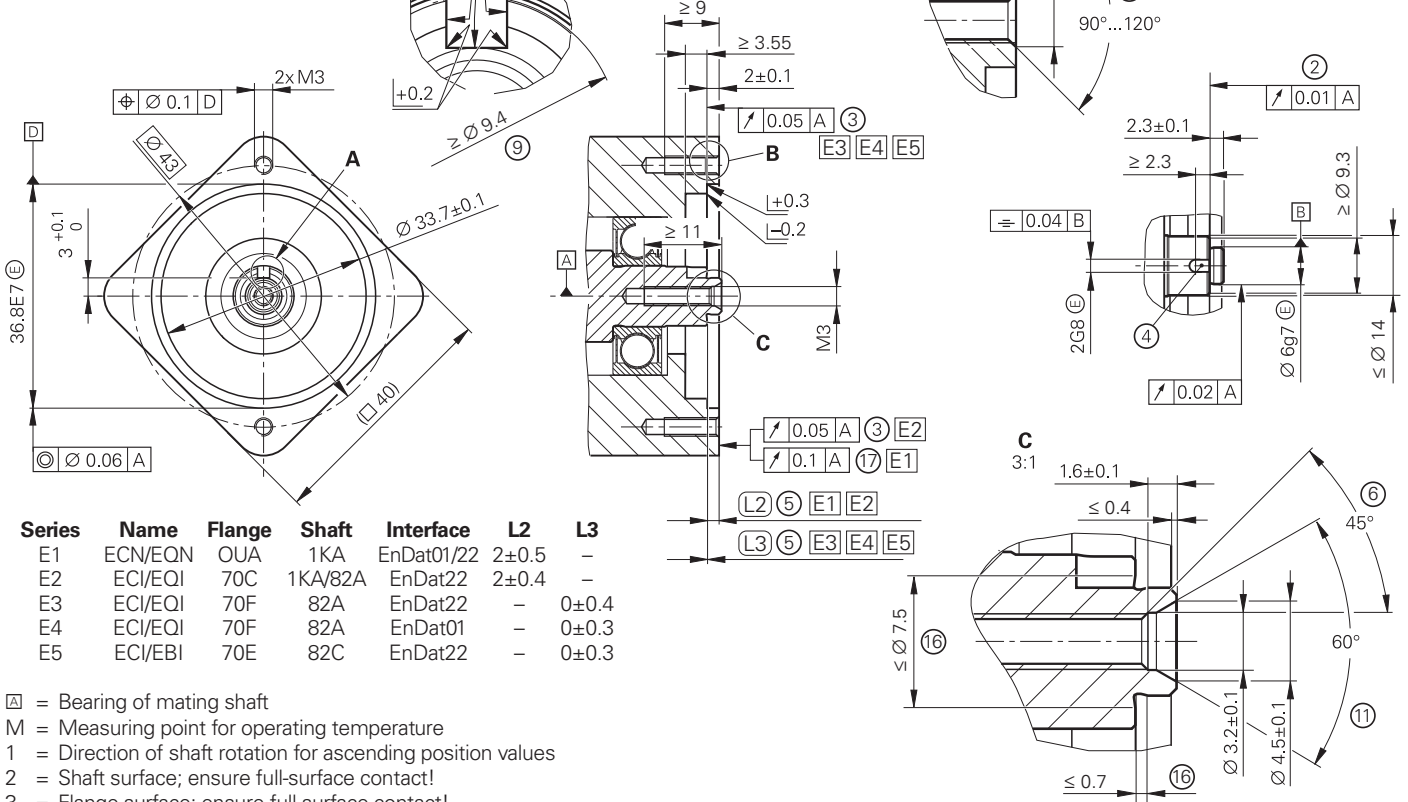

Series	Name	Flange	Shaft	Interface	L2	L3
E1	ECN/EQN	OQA	1KA	EnDat01/22	2±0.5	-
E2	ECI/EQI	70C	1KA/82A	EnDat22	2±0.4	-
E3	ECI/EQI	70F	82A	EnDat22	-	0±0.4
E4	ECI/EQI	70F	82A	EnDat01	-	0±0.3
E5	ECI/EBI	70E	82C	EnDat22	-	0±0.3

- ⊠ = Bearing of mating shaft
- M = Measuring point for operating temperature
- 1 = Direction of shaft rotation for ascending position values
- 2 = Shaft surface; ensure full-surface contact!
- 3 = Flange surface; ensure full-surface contact!
- 4 = Slot necessary only for 1KA shaft
- 5 = Maximum permissible deviation between shaft surface and flange surface; compensation of mounting tolerances and thermal expansion; ECI/EQI/EBI: dynamic motion permitted over entire range; ECN/EQN: ±0.15 mm dynamic axial motion permitted (with use of ATS software for mounting inspection, the display value for the mounting clearance is shown as 2 mm instead of 0 mm)
- 6 = Chamfer at start of thread is mandatory for material bonding anti-rotation lock
- 7 = Shaft fastening screw: DIN EN ISO 4762 – M3x25 – 8.8 with material bonding anti-rotation lock: ID 202264-86; tightening torque: 1 Nm ±0.1 Nm
- 8 = Clamping surface
- 9 = Contact surface of slot
- 10 = Possible flange fastening with fastening kit (ID 1264352-xx); tightening torque: 1 Nm ±0.1 Nm; pay attention to the orientation of the flat!
- 11 = Possible centering hole
- 12 = 15-pin header
- 13 = Dimension for JH standard cable
- 14 = Ensure installation space for cable
- 15 = Distance to cover; note the opening for header, header connector, and wires
- 16 = Undercut
- 17 = Coupling surface of ECN/EQN

	Singleturn	Multiturn
	ECI 1119	EQI 1131
Interface	EnDat 2.2	
Ordering designation	EnDat22	
Position values per rev.	524288 (19 bits)	
Revolutions	–	4096 (12 bits)
Calculation time t_{cal} Clock frequency	≤ 5 μs ≤ 16 MHz	
System accuracy	±120"	
Electrical connection	15-pin (with connection for external temperature sensor) ¹⁾	
Supply voltage	DC 3.6 V to 14 V	
Power consumption (max.)	3.6 V: ≤ 650 mW 14 V: ≤ 700 mW	3.6 V: ≤ 750 mW 14 V: ≤ 850 mW
Current consumption (typical)	5 V: 95 mA (without load)	5 V: 115 mA
Shaft	Blind hollow shaft for axial clamping Ø 6 mm	
Shaft speed	≤ 15000 rpm	≤ 12000 rpm
Moment of inertia of rotor	0.2 · 10 ⁻⁶ kgm ²	
Permiss. axial motion of measured shaft	±0.4 mm	
Vibration 55 Hz to 2000 Hz ²⁾ Shock 6 ms	Stator: ≤ 400 m/s ² ; Rotor: ≤ 600 m/s ² (EN 60068-2-6) ≤ 2000 m/s ² (EN 60068-2-27)	
Operating temperature	–40 °C to 110 °C	
Protection EN 60529	IP00 when mounted ³⁾	
Mass	≈ 0.04 kg	
ID number	1164812-xx	1164813-xx

¹⁾ Evaluation optimized for KTY 84-130 temperature sensor

²⁾ At 10 Hz to 55 Hz with constant amplitude



³⁾ Conformity with the EMC Directive must be ensured in the complete system

	Absolute	
	ECI 1118	EBI 1135
Interface	EnDat 2.2	
Ordering designation	EnDat22 ¹⁾	
Position values per rev.	262 144 (18 bits)	262 144 (18 bits; 19-bit data word length with LSB = 0)
Revolutions	–	65 536 (16 bits)
Calculation time t_{cal} Clock frequency	$\leq 6 \mu s$ $\leq 8 \text{ MHz}$	
System accuracy	$\pm 120''$	
Electrical connection	15-pin	
Supply voltage	DC 3.6 V to 14 V	<i>Rotary encoder</i> U_P : DC 3.6 V to 14 V <i>Backup battery</i> U_{BAT} : DC 3.6 V to 5.25 V
Power consumption (max.)	<i>Normal operation at 3.6 V</i> : 0.52 W <i>Normal operation at 14 V</i> : 0.6 W	
Current consumption (typical)	5 V: 80 mA (without load)	<i>Normal operation at 5 V</i> : 80 mA (without load) <i>Backup battery</i> ²⁾ : 22 μA (rotating shaft) 12 μA (at standstill)
Shaft	Blind hollow shaft $\varnothing 6 \text{ mm}$, axial clamping	
Mech. permiss. shaft speed n	$\leq 15000 \text{ rpm}$	$\leq 12000 \text{ rpm}$
Mech. permiss. acceleration	$\leq 10^5 \text{ rad/s}^2$	
Moment of inertia of rotor	$0.2 \cdot 10^{-6} \text{ kgm}^2$	
Permiss. axial motion of measured shaft	$\pm 0.3 \text{ mm}$	
Vibration 55 Hz to 2000 Hz Shock 6 ms	$\leq 300 \text{ m/s}^2$ (EN 60068-2-6) $\leq 1000 \text{ m/s}^2$ (EN 60068-2-27)	
Operating temperature	–20 °C to 115 °C	
Protection EN 60529	IP00 ³⁾	
Mass	$\approx 0.02 \text{ kg}$	
ID number	728563-xx	820725-xx

¹⁾ External temperature sensor and online diagnostics are not supported. Compliance with EnDat Specification 297403 and the EnDat Application Notes 722024, Chapter 13, *Battery-buffered encoders*, is required for correct control of the encoder

²⁾ At $T = 25 \text{ °C}$; $U_{BAT} = 3.6 \text{ V}$

³⁾ Conformity with the EMC Directive must be ensured in the complete system

	Absolute		
	ECI 1319 	EQI 1331 	EBI 1335 
Interface	EnDat 2.2		
Ordering designation	EnDat22		
Position values per rev.	524288 (19 bits)		
Revolutions	–	4096 (12 bits)	65536 (16 bits)
Elec. permiss. shaft speed/ deviations	≤ 15000 rpm (for continuous position value)		
Calculation time t_{cal} Clock frequency	≤ 5 μ s ≤ 16 MHz		
System accuracy	±65"		
Electrical connection	16-pin with connection for temperature sensor ¹⁾		
Cable length	≤ 100 m		
Supply voltage	DC 3.6 V to 14 V		<i>Rotary encoder U_P:</i> DC 3.6 V to 14 V <i>Backup battery U_{BAT}:</i> DC 3.6 V to 5.25 V
Power consumption (max.)	3.6 V: ≤ 0.65 W 14 V: ≤ 0.7 W	3.6 V: ≤ 0.75 W 14 V: ≤ 0.85 W	3.6 V: ≤ 0.65 W 14 V: ≤ 0.7 W
Current consumption (typical)	5 V: 95 mA (without load)	5 V: 115 mA (without load)	<i>Normal operation at 5 V:</i> 95 mA (without load) <i>Buffer mode:</i> 160 μ A (rotating shaft) ²⁾ 16 μ A (at standstill)
Shaft	Blind hollow shaft for axial clamping \varnothing 12.7 mm		
Mech. permiss. shaft speed n	≤ 15000 rpm	≤ 12000 rpm	
Moment of inertia of rotor	2.6 · 10 ⁻⁶ kgm ²		
Permiss. axial motion of measured shaft	±0.5 mm		
Vibration 55 Hz to 2000 Hz ³⁾ Shock 6 ms	<i>Stator:</i> ≤ 400 m/s ² ; <i>rotor:</i> ≤ 600 m/s ² (EN 60068-2-6) ≤ 2000 m/s ² (EN 60068-2-27)		
Operating temperature	–40 °C to 115 °C		
Trigger threshold of temperature exceedance error message	130 °C (measuring accuracy of the internal temperature sensor: ±1 K)		
Protection EN 60529	IP20 when mounted		
Mass	≈ 0.13 kg		
ID number	810661-xx	810662-xx	1230275-xx

¹⁾ Evaluation optimized for KTY 84-130

²⁾ At T = 25 °C; U_{BAT} = 3.6 V

³⁾ 10 Hz to 55 Hz, 4.9 mm constant peak to peak

Functional safety is available. For dimensions and specifications, see the Product Information document.

ECI/EQI 1300S series

Absolute rotary encoders

- Mounting-compatible with photoelectric rotary encoders with a 07B stator coupling
- 0YA flange for axial mounting
- 44C blind hollow shaft $\varnothing 12.7$ mm
- Without integral bearing
- Cost-optimized mating dimensions upon request

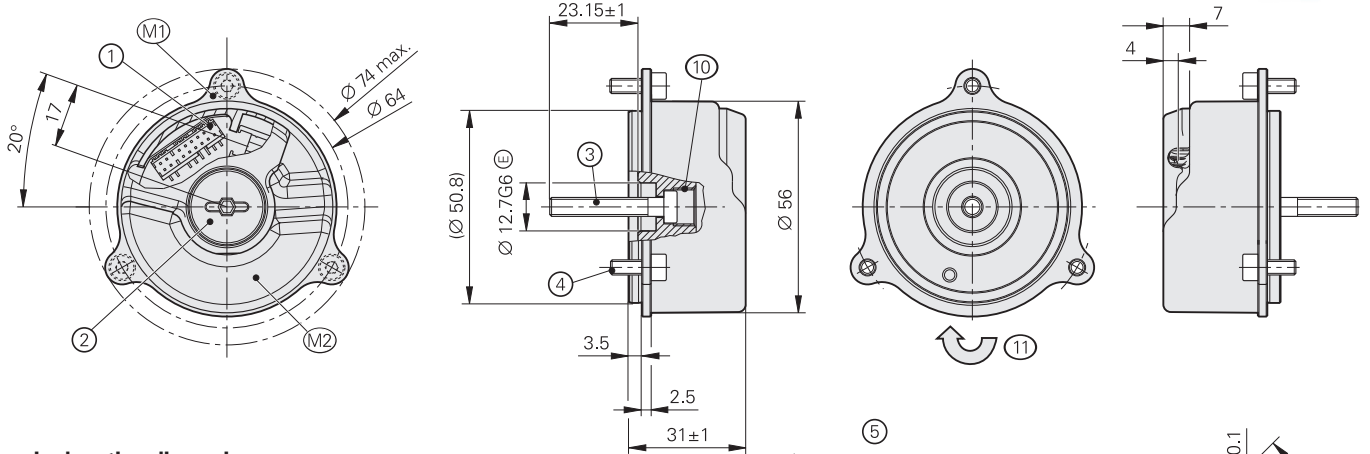

Required mating dimensions

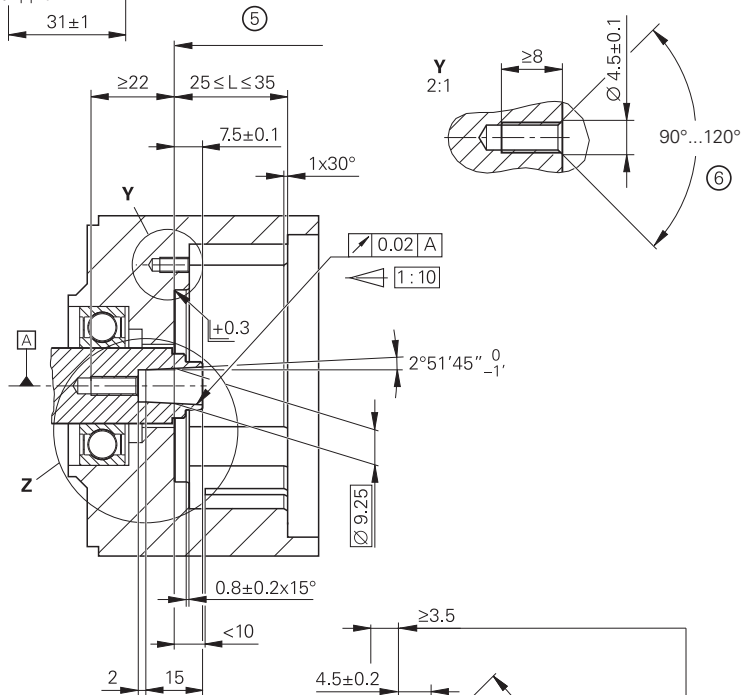
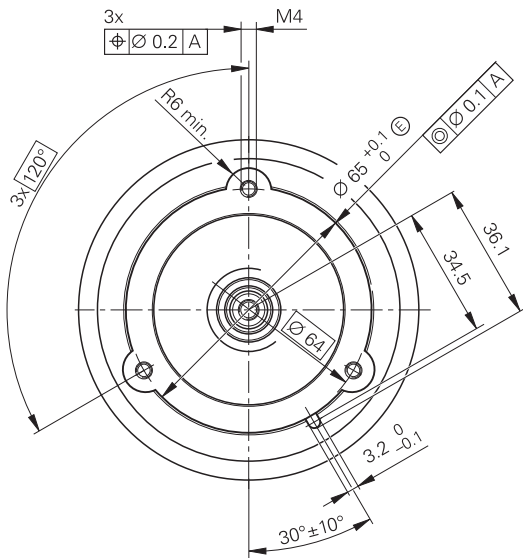



D1	D2
$\varnothing 12.7G6 \text{ (E)}$	$\varnothing 12.7h6 \text{ (E)}$

mm

 Tolerancing ISO 8015
 ISO 2768 - m H
 < 6 mm: ± 0.2 mm

- ▣ = Bearing of mating shaft
- M1 = Measuring point for operating temperature
- M2 = Measuring point for vibration; see also D 741714
- 1 = 16-pin PCB connector
- 2 = Screw plug; widths A/F 3 and 4; tightening torque: 5 Nm +0.5 Nm
- 3 = Screw: DIN 6912 - M5x30 - 08.8 - MKL; width A/F 4; tightening torque: 5 Nm +0.5 Nm
- 4 = Screw: ISO 4762 - M4x10 - 8.8 - MKL; width A/F 3; tightening torque: 2 Nm ± 0.1 Nm
- 5 = Functional diameter of taper for ECN/EQN 13xx
- 6 = Chamfer at start of thread is mandatory for material bonding anti-rotation lock
- 7 = Flange surface of ExI/resolver; ensure full-surface contact!
- 8 = Shaft surface; ensure full-surface contact!
- 9 = Maximum permissible deviation between the shaft surface and flange surface; compensation of mounting tolerances and thermal expansion; ECI/EQI: dynamic motion permitted over entire range; ECN/EQN: no dynamic motion permitted
- 10 = M10 back-off thread
- 11 = Direction of shaft rotation for ascending position values

Absolute	
ECI 1319 S 	EQI 1331 S 
Interface	DRIVE-CLiQ
Ordering designation	DQ01
Position values per rev.	524288 (19 bits)
Revolutions	– 4096 (12 bits)
Calculation time TIME_MAX_ACTVAL	≤ 12 μs
System accuracy	±65"
Electrical connection	16-pin with connection for temperature sensor ¹⁾
Cable length	≤ 40 m (see description in the <i>Interfaces of HEIDENHAIN Encoders</i> brochure)
Supply voltage	DC 24 V (10 V to 28.8 V; up to DC 36 V possible without limiting the functional safety)
Power consumption (max.)	10 V: ≤ 1100 mW 28.8 V: ≤ 1250 mW 10 V: ≤ 1200 mW 28.8 V: ≤ 1350 mW
Current consumption (typical)	24 V: 40 mA (without load) 24 V: 45 mA (without load)
Shaft	Blind hollow shaft for axial clamping Ø 12.7 mm
Mech. permiss. shaft speed <i>n</i>	≤ 15000 rpm ≤ 12000 rpm
Moment of inertia of rotor	2.6 · 10 ⁻⁶ kgm ²
Permiss. axial motion of measured shaft	±0.5 mm
Vibration 55 Hz to 2000 Hz ²⁾ Shock 6 ms	Stator: ≤ 400 m/s ² ; rotor: ≤ 600 m/s ² (EN 60068-2-6) ≤ 2000 m/s ² (EN 60068-2-27)
Operating temperature	-40 °C to 100 °C
Trigger threshold of temperature exceedance error message	120 °C (measuring accuracy of the internal temperature sensor: ±1 K)
Protection EN 60529	IP20 when mounted
Mass	≈ 0.13 kg
ID number	1222049-xx 1222051-xx

¹⁾ See *Temperature measurement in motors*

²⁾ 10 Hz to 55 Hz, 4.9 mm constant peak to peak

Functional safety is available. For dimensions and specifications, see the Product Information document.

DRIVE-CLiQ is a registered trademark of Siemens AG.

ECI/EBI 100 series

Absolute rotary encoders

- Flange for axial mounting
- Hollow through shaft
- Without integral bearing
- **EBI 135: multitem functionality via battery-buffered revolution counter**

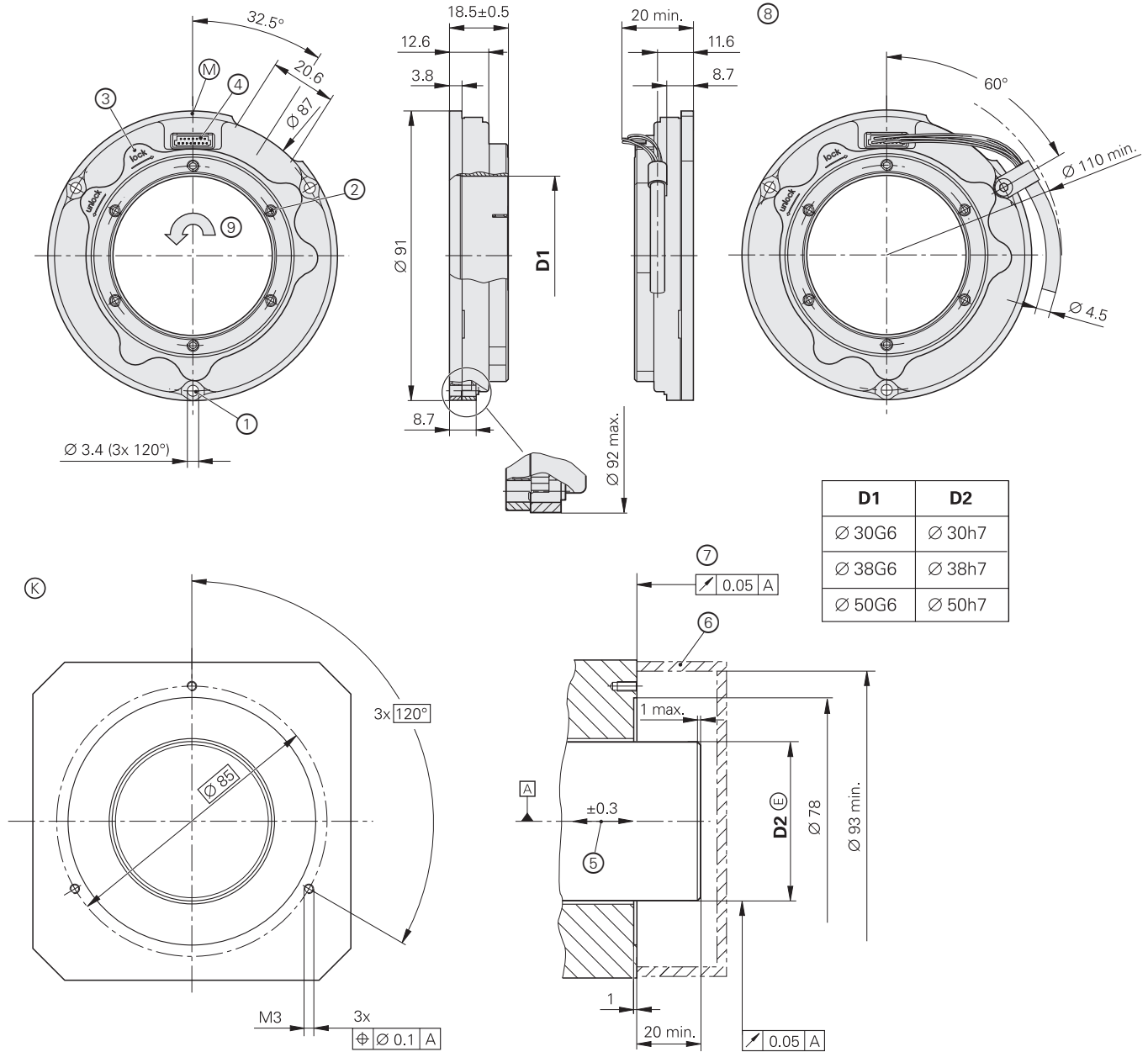

mm

 Tolerancing ISO 8015
 ISO 2768 - m H
 <math>< 6\text{ mm}</math>: $\pm 0.2\text{ mm}$

- ▣ = Bearing of mating shaft
- ⊙ = Required mating dimensions
- M = Measuring point for operating temperature
- 1 = Cylinder head screw: ISO 4762-M3, with three ISO 7092 washers; tightening torque: $0.9\text{ Nm} \pm 0.05\text{ Nm}$
- 2 = Width A/F 2.0 (6x); tighten evenly crosswise with increasing tightening torque; final tightening torque: $0.5\text{ Nm} \pm 0.05\text{ Nm}$
- 3 = Shaft detent: for manner of functioning, see the mounting instructions
- 4 = 15-pin PCB connector
- 5 = Compensation of mounting tolerances and thermal expansion; no dynamic motion
- 6 = Protection against contact as per EN 60529
- 7 = Required up to max. $\text{Ø} 92\text{ mm}$
- 8 = Required mounting frame for output cable with cable clamp (accessory); bending radius of connecting wires: at least R3
- 9 = Direction of shaft rotation for ascending position values

	Absolute		
	ECI 119		EBI 135
Interface*	EnDat 2.1	EnDat 2.2	EnDat 2.2
Ordering designation	EnDat01	EnDat22 ¹⁾	EnDat22 ¹⁾
Position values per rev.	524288 (19 bits)		
Revolutions	–		65536 (16 bits) ²⁾
Elec. permiss. shaft speed/ deviations ³⁾	≤ 3000 rpm/±128 LSB ≤ 6000 rpm/±256 LSB	≤ 6000 rpm (for continuous position value)	
Calculation time t_{cal} Clock frequency	≤ 8 μs ≤ 2 MHz	≤ 6 μs ≤ 16 MHz	
Incremental signals	 1 V _{PP}	–	–
Line count	32	–	–
Cutoff frequency –3 dB	≥ 6 kHz (typical)	–	–
System accuracy	±90"		
Electrical connection	15-pin	15-pin with connection for temperature sensor ⁵⁾	
Supply voltage	DC 3.6 V to 14 V		<i>Rotary encoder</i> U _P : DC 3.6 V to 14 V <i>Backup battery</i> U _{BAT} : DC 3.6 V to 5.25 V
Power consumption (max.)	3.6 V: ≤ 0.58 W 14 V: ≤ 0.7 W	<i>Normal operation at 3.6 V</i> : 0.53 W <i>Normal operation at 14 V</i> : 0.63 W	
Current consumption (typical)	5 V: 80 mA (without load)	5 V: 75 mA (without load)	<i>Normal operation at 5 V</i> : 75 mA (without load) <i>Buffer mode</i> ⁴⁾ : 25 μA (rotating shaft) 12 μA (at standstill)
Shaft*	Hollow through shaft: Ø = 30 mm, 38 mm, 50 mm		
Mech. permiss. shaft speed n	≤ 6000 rpm		
Moment of inertia of rotor	Ø = 30 mm: $64 \cdot 10^{-6}$ kgm ² Ø = 38 mm: $58 \cdot 10^{-6}$ kgm ² Ø = 50 mm: $64 \cdot 10^{-6}$ kgm ²		
Permiss. axial motion of measured shaft	±0.3 mm		
Vibration 55 Hz to 2000 Hz ⁶⁾ Shock 6 ms	≤ 300 m/s ² (EN 60068-2-6) ≤ 1000 m/s ² (EN 60068-2-27)		
Operating temperature	–30 °C to 115 °C		
Protection EN 60529	IP20 when mounted ⁷⁾		
Mass	Ø = 30 mm: ≈ 0.19 kg Ø = 38 mm: ≈ 0.16 kg Ø = 50 mm: ≈ 0.14 kg		
ID number	823406-xx	823407-xx	823405-xx

* Please select when ordering

¹⁾ Valuation numbers are not supported

²⁾ Compliance with EnDat Specification 297403 and EnDat Application Notes 722024, Chapter 13, *Battery-buffered encoders*, is required for correct control of the encoder

³⁾ Speed-dependent deviations between absolute and incremental signals

⁴⁾ At T = 25 °C; U_{BAT} = 3.6 V

⁵⁾ Evaluation optimized for KTY 84-130

⁶⁾ 10 to 55 Hz, 4.9 mm constant peak to peak

⁷⁾ Conformity with the EMC Directive must be ensured in the complete system

ECI 4010, EBI 4010, ECI 4090S

Rotary encoders for absolute position values

- Robust inductive scanning principle
- Hollow through shaft (Ø 90 mm)
- **EBI 4010**: multiturn functionality through battery-buffered revolution counter
- Consists of a scanning unit and scale drum

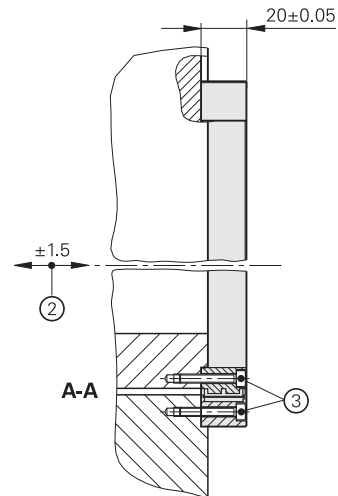
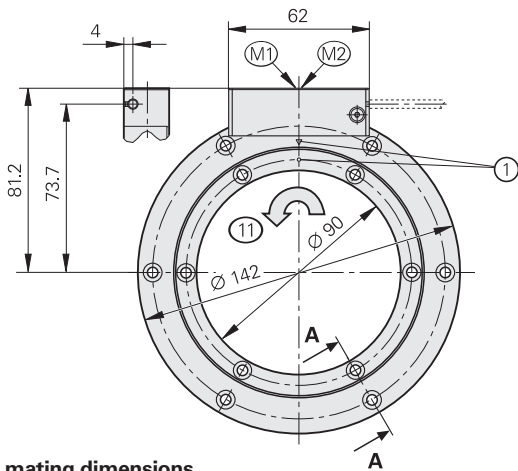

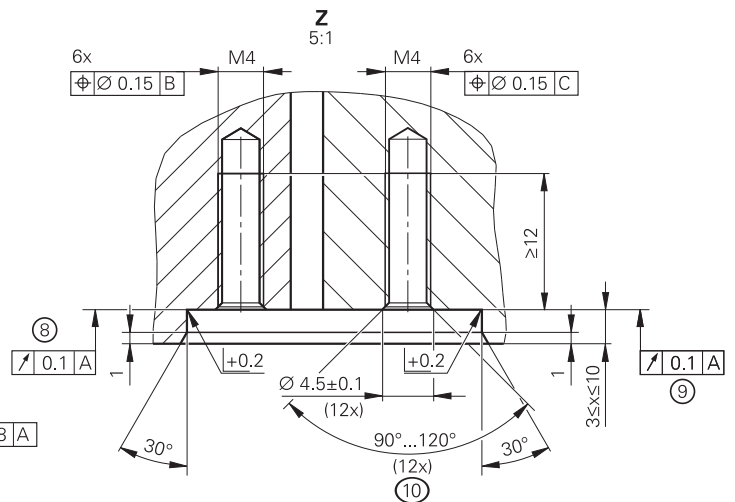
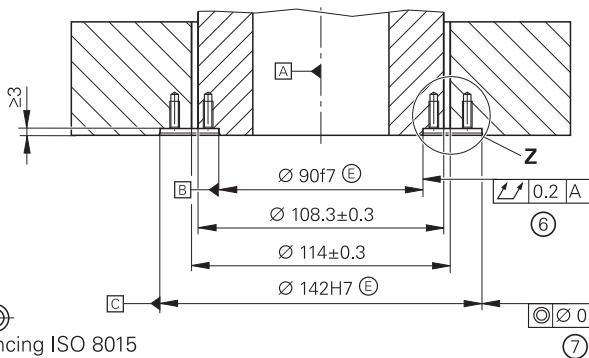
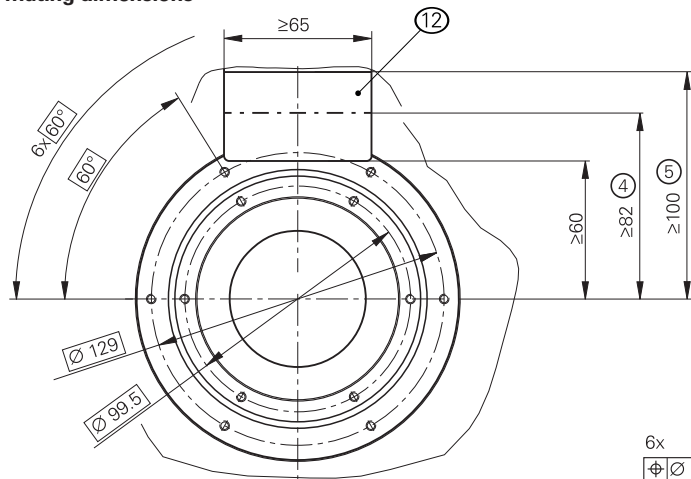

Required mating dimensions



mm
 Tolerancing ISO 8015
 ISO 2768 - m H
 < 6 mm: ± 0.2 mm

- ▣ = Bearing of mating shaft
- M1 = Measuring point for operating temperature on housing
- M2 = Measuring point for vibration on housing
- 1 = Position of zero point ± 5°
- 2 = Maximum permissible axial deviation between the shaft surface and flange surface; compensation of mounting tolerances and thermal expansion; dynamic motion permitted over entire range
- 3 = Use screws with material bonding anti-rotation lock: ISO 4762 – M4 x 25 – 8.8 – MKL as per DIN 267-27 (not included in delivery, ID 202264-88); tightening torque: 2.2 Nm ± 0.13 Nm
- 4 = Space required when encoder cover is closed
- 5 = Space required for opening the encoder cover
- 6 = Total runout of mating shaft
- 7 = Coaxiality of stator mating surface
- 8 = Bearing surface of rotor
- 9 = Bearing surface of stator
- 10 = Chamfer at start of thread is mandatory for material bonding anti-rotation lock
- 11 = Direction of shaft rotation for ascending position values
- 12 = This area of the mating surface does not need to be fully covered by the scanning unit

Specifications	ECI 4010 – Singleturn 	EBI 4010 – Multiturn 	ECI 4090 S – Singleturn 
Interface/ordering designation	EnDat 2.2 / EnDat22		DRIVE-CLiQ / DQ01
Position values per rev.	1 048 576 (20 bits)		
Revolutions	–	65 536 (16 bits)	–
Calculation time t_{cal} /clock frequency	$\leq 5 \mu s / \leq 16 \text{ MHz}$		$\leq 11 \mu s^1$
System accuracy	$\pm 25''$		
Electrical connection	15-pin with connection for temperature sensor ²⁾		
Cable length	$\leq 100 \text{ m}$ (see the EnDat description in the <i>Interfaces of HEIDENHAIN Encoders</i> brochure)		$\leq 40 \text{ m}^3$ (see description in the <i>Interfaces of HEIDENHAIN Encoders</i> brochure)
Supply voltage	DC 3.6 V to 14 V	Rotary encoder U_P : DC 3.6 V to 14 V Buffer battery U_{BAT} : 3.6 to 5.25 V DC	DC 24 V (10 V to 28.8 V); up to 36 V possible without limiting the functional safety
Power consumption ⁴⁾ (maximum)	3.6 V: $\leq 630 \text{ mW}$; 14 V: $\leq 700 \text{ mW}$		10 V: $\leq 1100 \text{ mW}$; 28.8 V: $\leq 1250 \text{ mW}$
Current consumption (typical)	5 V: 95 mA (without load)	Normal operation at 5 V: 95 mA (without load) Buffer mode ⁵⁾ : 220 μA (rotating shaft) 25 μA (at standstill)	24 V: 40 mA (without load)
Shaft	Hollow through shaft ($\varnothing 90 \text{ mm}$)		
Shaft speed	$\leq 6000 \text{ rpm}$		
Moment of inertia of rotor	$4.26 \cdot 10^{-4} \text{ kgm}^2$ (without screws)		
Angular acceleration of rotor	$\leq 2 \cdot 10^4 \text{ rad/s}^2$		
Axial motion of measured shaft	$\leq \pm 1.5 \text{ mm}$		
Vibration 55 Hz to 2000 Hz ⁶⁾ Shock 6 ms	AE scanning unit: $\leq 400 \text{ m/s}^2$; TTR scale drum: $\leq 600 \text{ m/s}^2$ (EN 60068-2-6) $\leq 2000 \text{ m/s}^2$ (EN 60068-2-27)		
Operating temperature	–40 °C to 115 °C (at the measuring point and on the entire scale drum)		–40 °C to 100 °C (at the measuring point and on the entire scale drum)
Trigger threshold of temperature exceedance error message	130 °C (measuring accuracy of the internal temperature sensor: $\pm 1 \text{ K}$)		120 °C (measuring accuracy of the internal temperature sensor: $\pm 1 \text{ K}$)
Protection EN 60529	Complete encoder, mounted: IP20 ⁷⁾ ; scanning unit: IP40 (read about isolation under <i>Electrical safety</i> in the <i>Interfaces of HEIDENHAIN Encoders</i> brochure)		
Mass	AE scanning unit: $\approx 0.27 \text{ kg}$; TTR scale drum: $\approx 0.17 \text{ kg}$		
ID number	AE ECI4010 scanning unit: ID 1130167-xx	AE EBI4010 scanning unit: ID 1130173-xx	AE ECI4090S scanning unit: ID 1130171-xx
	TTR EXI4000 scale drum: ID 1130175-xx		

¹⁾ Calculation time TIME_MAX_ACTUAL

²⁾ See *Temperature measurement in motors*

³⁾ At an output cable length (inside motor) $\leq 1 \text{ m}$

⁴⁾ See *General electrical information* in the *Interfaces of HEIDENHAIN Encoders* brochure

⁵⁾ At $T = 25 \text{ °C}$; $U_{BAT} = 3.6 \text{ V}$

⁶⁾ AE: 10 Hz to 55 Hz, 6.5 mm constant peak to peak; TTR: 10 Hz to 55 Hz, 10 mm constant peak to peak

⁷⁾ The encoder must be protected from abrasive and harmful media in the application; use an appropriate enclosure as needed
Functional safety is available. For dimensions and specifications, see the Product Information document.

ECI 4010, EBI 4010, ECI 4090S

Rotary encoders for absolute position values

- Robust inductive scanning principle
- Hollow through shaft (Ø 180 mm)
- **EBI 4010:** multitum functionality through battery-buffered revolution counter
- Consists of a scanning unit and scale drum

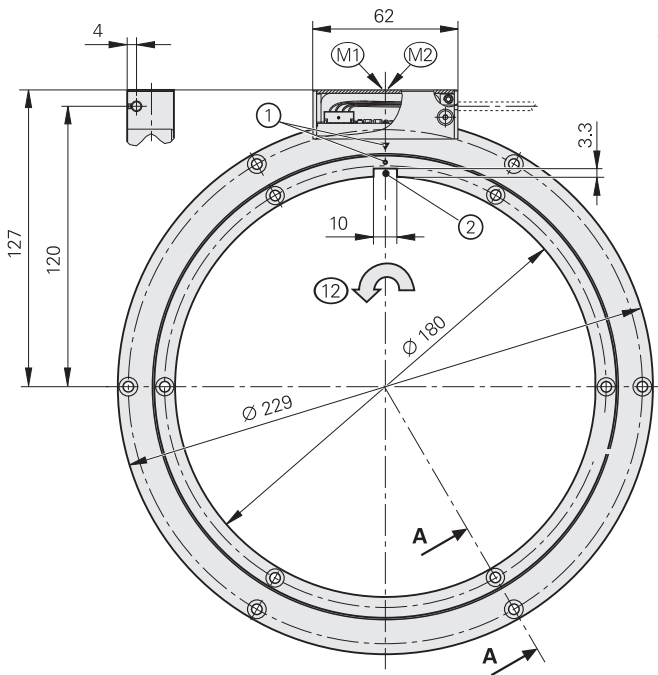

Functional Safety

Shown with customer's side

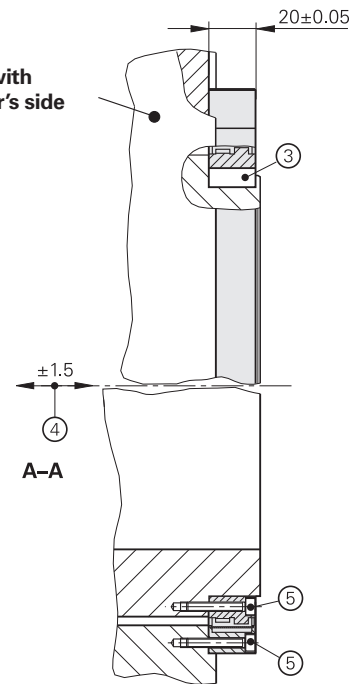

Required mating dimensions

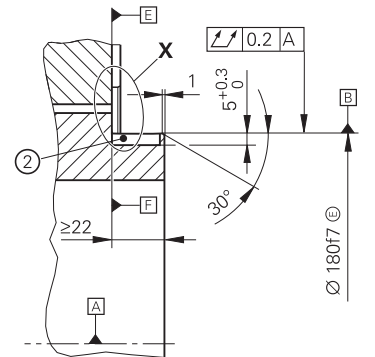
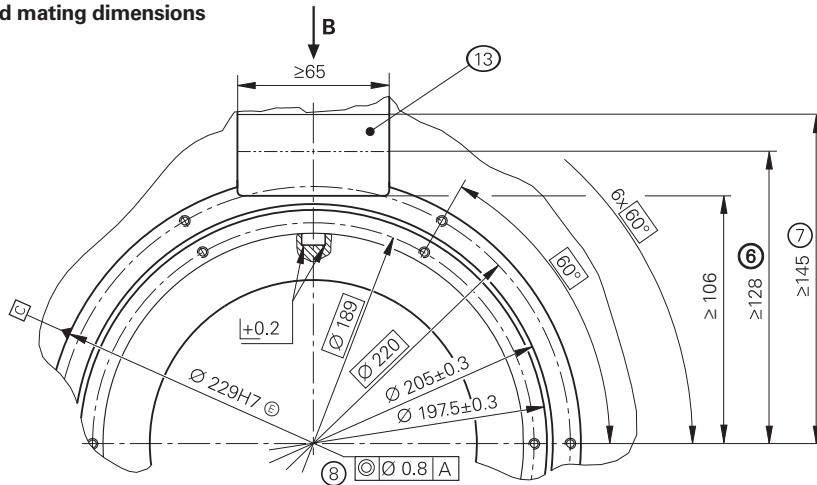

mm

 Tolerancing ISO 8015
 ISO 2768 - m H
 < 6 mm: ± 0.2 mm

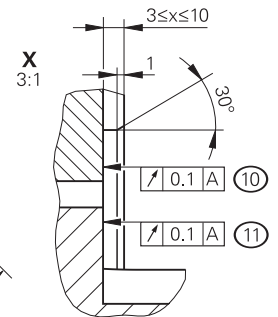
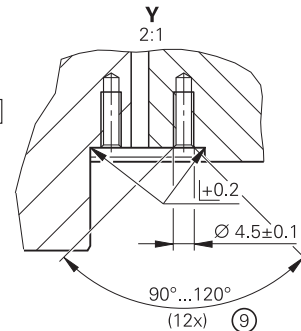
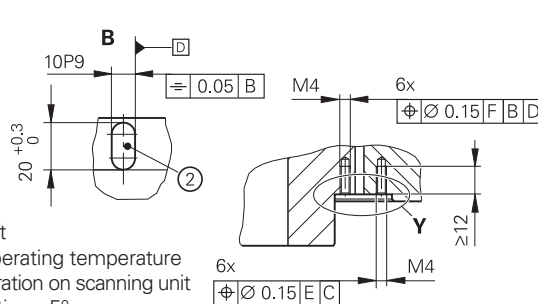

⊠ = Bearing of mating shaft

M1 = Measuring point for operating temperature

M2 = Measuring point for vibration on scanning unit

1 = Marking of the 0° position ± 5°

2 = Keyway: DIN 6885-A 10x8x20

3 = Key: DIN 6885-A 10x8x20

4 = Maximum permissible axial deviation between the shaft surface and flange surface;

compensation of mounting tolerances and thermal expansion; dynamic motion permitted over entire range

5 = Fastening screws: ISO 4762 – M4 x 25 – 8.8; tightening torque: 2.2 Nm ± 0.13 Nm; a suitable anti-rotation lock must be used for the screw connection (e.g., screw with material bonding anti-rotation lock: ISO 4762 – M4 x 25 – 8.8 MKL as per DIN 267-27, ID 202264-88)

6 = Space required when encoder cover is closed

7 = Space required for opening the encoder cover

8 = Coaxiality of stator mating surface



9 = Chamfer at start of thread is mandatory for material bonding anti-rotation lock

10 = Bearing surface of rotor

11 = Bearing surface of stator

12 = Direction of shaft rotation for ascending position values

13 = In this area, the mating surface does not need to be fully covered by the scanning unit

Specifications	ECI 4010 – Singleturm 	EBI 4010 – Multiturm 	ECI 4090 S – Singleturm 
Interface/ordering designation	EnDat 2.2 / EnDat22		DRIVE-CLiQ / DQ01
Position values per rev.	1 048 576 (20 bits)		
Revolutions	–	65 536 (16 bits)	–
Calculation time t_{cal} / clock frequency	$\leq 5 \mu s / \leq 16 \text{ MHz}$		$\leq 11 \mu s^1$
System accuracy	$\pm 40''$		
Electrical connection	15-pin with connection for temperature sensor ²⁾		
Cable length	$\leq 100 \text{ m}$ (see the EnDat description in the <i>Interfaces of HEIDENHAIN Encoders</i> brochure)		$\leq 40 \text{ m}^3$ (see description in the <i>Interfaces of HEIDENHAIN Encoders</i> brochure)
Supply voltage	DC 3.6 V to 14 V	Rotary encoder U_P : DC 3.6 V to 14 V Buffer battery U_{BAT} : 3.6 to 5.25 V DC	DC 24 V (10 V to 28.8 V); up to 36 V possible without limiting the functional safety
Power consumption ⁴⁾ (maximum)	3.6 V: $\leq 630 \text{ mW}$; 14 V: $\leq 700 \text{ mW}$		10 V: $\leq 1100 \text{ mW}$; 28.8 V: $\leq 1250 \text{ mW}$
Current consumption (typical)	5 V: 95 mA (without load)	Normal operation at 5 V: 95 mA (without load) Buffer mode ⁵⁾ : 220 μA (rotating shaft) 25 μA (at standstill)	24 V: 40 mA (without load)
Shaft	Hollow through shaft $\varnothing 180 \text{ mm}$ (with keyway)		
Shaft speed	$\leq 6000 \text{ rpm}$		
Moment of inertia of rotor	$3.1 \cdot 10^{-3} \text{ kgm}^2$ (without screws, without key)		
Angular acceleration of rotor	$\leq 2 \cdot 10^4 \text{ rad/s}^2$		
Axial motion of measured shaft	$\leq \pm 1.5 \text{ mm}$		
Vibration 55 Hz to 2000 Hz ⁶⁾ Shock 6 ms	AE scanning unit: $\leq 400 \text{ m/s}^2$; TTR scale drum: $\leq 600 \text{ m/s}^2$ (EN 60068-2-6) $\leq 2000 \text{ m/s}^2$ (EN 60068-2-27)		
Operating temperature	–40 °C to 115 °C (at the measuring point and on the entire scale drum)		–40 °C to 100 °C (at the measuring point and on the entire scale drum)
Trigger threshold of temperature exceedance error message	130 °C (measuring accuracy of the internal temperature sensor: $\pm 1 \text{ K}$)		120 °C (measuring accuracy of the internal temperature sensor: $\pm 1 \text{ K}$)
Protection EN 60529	Complete encoder, mounted: IP20 ⁷⁾ ; scanning unit: IP40 (read about isolation under <i>Electrical safety</i> in the <i>Interfaces of HEIDENHAIN Encoders</i> brochure)		
Mass	AE scanning unit: $\approx 0.39 \text{ kg}$; TTR scale drum: $\approx 0.33 \text{ kg}$		
ID number	AE ECI4010 scanning unit: ID 1087526-xx	AE EBI4010 scanning unit: ID 1097530-xx	AE ECI4090S scanning unit: ID 1087527-xx
	TTR EXI4000 scale drum: ID 1113606-xx		

¹⁾ Calculation time TIME_MAX_ACTUAL

²⁾ See *Temperature measurement in motors*

³⁾ At an output cable length (inside motor) $\leq 1 \text{ m}$

⁴⁾ See *General electrical information* in the *Interfaces of HEIDENHAIN Encoders* brochure

⁵⁾ At $T = 25 \text{ °C}$; $U_{BAT} = 3.6 \text{ V}$

⁶⁾ AE: 10 Hz to 55 Hz, 6.5 mm constant peak to peak; TTR: 10 Hz to 55 Hz, 10 mm constant peak to peak

⁷⁾ The encoder must be protected from abrasive and harmful media in the application; use an appropriate enclosure as needed
Functional safety is available. For dimensions and specifications, see the Product Information document.

	Incremental	
	ERO 1225	ERO 1285
Interface	□□TTL	~ 1 V _{PP}
Line count*	1024 2048	
Accuracy of graduation ²⁾	±6"	
Reference mark	One	
Output frequency Edge separation <i>a</i> Cutoff frequency -3 dB	≤ 300 kHz ≥ 0.39 μs -	- - ≥ 180 kHz (typical)
System accuracy ¹⁾	1024 lines: ±92" 2048 lines: ±73"	1024 lines: ±67" 2048 lines: ±60"
Electrical connection	12-pin	
Supply voltage	DC 5 V ±0.5 V	
Current consumption (without load)	≤ 150 mA	
Shaft*	Hollow through shaft Ø = 10 mm or Ø = 12 mm	
Moment of inertia of rotor	Shaft Ø 10 mm: 2.2 · 10 ⁻⁶ kgm ² Shaft Ø 12 mm: 2.2 · 10 ⁻⁶ kgm ²	
Mech. permiss. shaft speed <i>n</i>	≤ 25000 rpm	
Permiss. axial motion of measured shaft	1024 lines: ±0.2 mm 2048 lines: ±0.05 mm	±0.03 mm
Vibration 55 Hz to 2000 Hz Shock 6 ms	≤ 100 m/s ² (EN 60068-2-6) ≤ 1000 m/s ² (EN 60068-2-27)	
Operating temperature	-40 °C to 100 °C	
Protection EN 60529	IP00 ³⁾	
Mass	≈ 0.07 kg	
ID number	1037521-xx (scanning unit) 332378-xx (disk/hub assembly)	1037522-xx (scanning unit) 332378-xx (disk/hub assembly)

* Please select when ordering

¹⁾ When not mounted; additional deviations due to mounting and bearing of the measured shaft are not taken into account

²⁾ For other errors, see *Measuring accuracy*

³⁾ Compliance with the EMC Directive must be ensured in the complete system through appropriate measures taken during mounting

ERO 1400 series

Incremental rotary encoders

- Flange for axial mounting
- Hollow through shaft
- Without integral bearing; self-centering

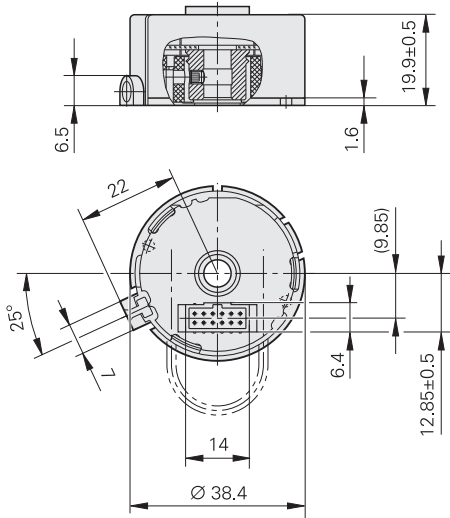

With axial PCB connector

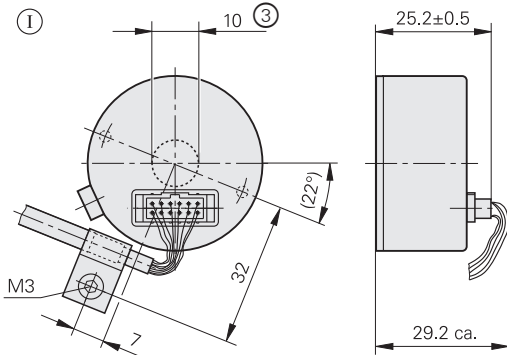
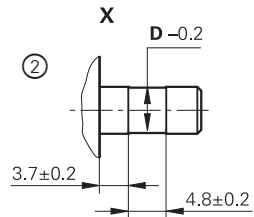
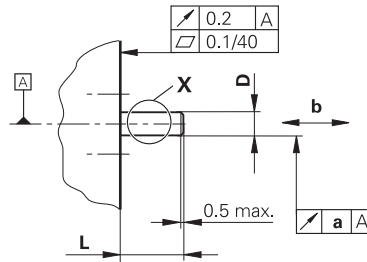
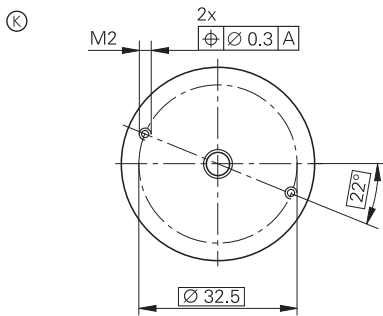
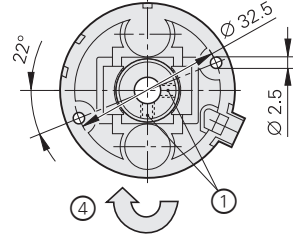
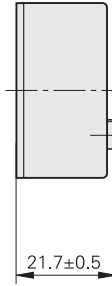

Axial PCB connector and round cable

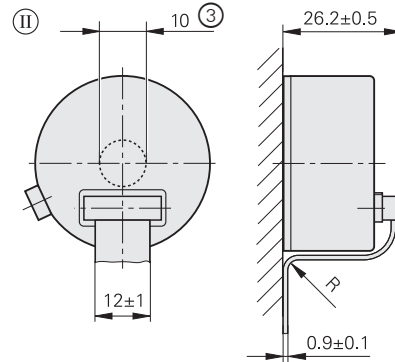

Axial PCB connector and ribbon cable

mm

 Tolerancing ISO 8015
 ISO 2768 - m H
 < 6 mm: ±0.2 mm

L	13 +4.5/-3	10 min.

- ⊠ = Bearing of mating shaft
- ⊙ = Required mating dimensions
- ① = Accessory: round cable
- ② = Accessory: ribbon cable
- 1 = Two M3 setscrews offset by 90°; width A/F 1.5; M_d = 0.25 Nm ±0.05 Nm
- 2 = Version for repeated mounting
- 3 = Version featuring housing with central hole (accessory)
- 4 = Direction of shaft rotation for ascending position values

Bend radius R	Fixed cable	Frequent flexing
Ribbon cable	R ≥ 2 mm	R ≥ 10 mm

	a	b	D
ERO 1420	0.03	±0.1	Ø 4h6 ⊕
ERO 1470	0.02	±0.05	Ø 6h6 ⊕
ERO 1480			Ø 8h6 ⊕

	Incremental					
	ERO 1420		ERO 1470			ERO 1480
Interface	□□TTL					~ 1 V _{PP}
Line count*	512 1000 1024	1000 1500			512 1000 1024	
Integrated interpolation*	–	5-fold	10-fold	20-fold	25-fold	–
Signal periods per rev.	512 1000 1024	5000 7500	10000 15000	20000 30000	25000 37500	512 1000 1024
Edge separation <i>a</i>	≥ 0.39 μs	≥ 0.47 μs	≥ 0.22 μs	≥ 0.17 μs	≥ 0.07 μs	–
Scanning frequency	≤ 300 kHz	≤ 100 kHz		≤ 62.5 kHz	≤ 100 kHz	–
Cutoff frequency –3 dB	–					≥ 180 kHz
Reference mark	One					
System accuracy ¹⁾	512 lines: ±139" 1000 lines: ±112" 1024 lines: ±112"		1000 lines: ±130" 1500 lines: ±114"			512 lines: ±190" 1000 lines: ±163" 1024 lines: ±163"
Electrical connection*	12-pin, axial ³⁾					
Supply voltage	DC 5 V ±0.5 V	DC 5 V ±0.25 V			DC 5 V ±0.5 V	
Current consumption (without load)	≤ 150 mA	≤ 155 mA		≤ 200 mA	≤ 150 mA	
Shaft*	Blind hollow shaft Ø = 4 mm, Ø = 6 mm , or Ø = 8 mm, or hollow through shaft in housing with bore (accessory)					
Moment of inertia of rotor	Shaft Ø 4 mm: 0.28 · 10 ⁻⁶ kgm ² Shaft Ø 6 mm: 0.27 · 10 ⁻⁶ kgm ² Shaft Ø 8 mm: 0.25 · 10 ⁻⁶ kgm ²					
Mech. permiss. shaft speed <i>n</i>	≤ 30000 rpm					
Permiss. axial motion of measured shaft	±0.1 mm	±0.05 mm				
Vibration 55 Hz to 2000 Hz Shock 6 ms	≤ 100 m/s ² (EN 60068-2-6) ≤ 1000 m/s ² (EN 60068-2-27)					
Operating temperature	–10 °C to 70 °C					
Protection EN 60529	With PCB connector: IP00 ²⁾ With cable outlet: IP40					
Mass	≈ 0.07 kg					
ID number	360731-xx	360736-xx			360737-xx	

Bold: This preferred version is available on short notice

* Please select when ordering

¹⁾ When not mounted; additional deviations due to mounting and bearing of the measured shaft are not taken into account

²⁾ Conformity with the EMC Directive must be ensured in the complete system

³⁾ Upon request, cable (1 m), radial, free cable end (not for ERO 1470)

Interfaces

~ 1 V_{PP} incremental signals

HEIDENHAIN encoders with the ~ 1 V_{PP} interface provide voltage signals that are highly interpolatable.

The sinusoidal **incremental signals** A and B are phase-shifted by 90° elec. and have a typical amplitude of 1 V_{PP}. The illustrated sequence of output signals—with B lagging A—applies to the direction of motion shown in the dimension drawing. The **reference mark signal** R has a unique assignment to the incremental signals. The output signal may be lower next to the reference mark.

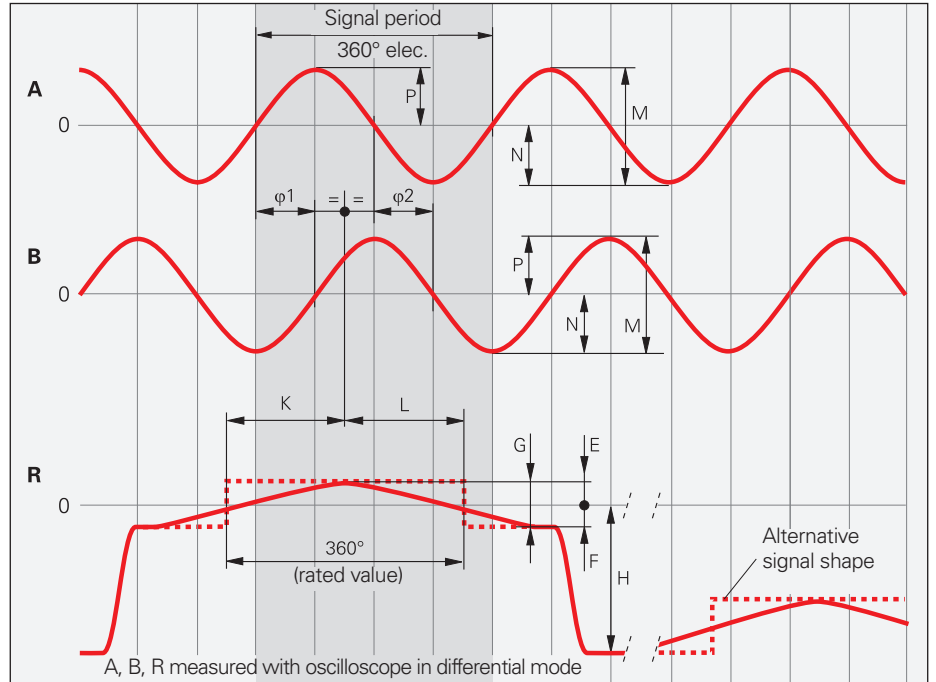

Further information:

Detailed descriptions of all available interfaces, as well as general electrical information, can be found in the *Interfaces of HEIDENHAIN Encoders* brochure.

Pin layout

12-pin M23 coupling	15-pin D-sub connector for PWM 21				12-pin PCB connector									
	Power supply				Incremental signals						Other signals			
	12	2	10	11	5	6	8	1	3	4	9	7	/	
	4	12	2	10	1	9	3	11	14	7	5/6/8/15	13	/	
	2a	2b	1a	1b	6b	6a	5b	5a	4b	4a	3b	3a	/	
	U _P	Sensor ¹⁾ U _P	0V	Sensor ¹⁾ 0V	A+	A-	B+	B-	R+	R-	Vacant	Vacant	Vacant	
	Brown/ Green	Blue	White/ Green	White	Brown	Green	Gray	Pink	Red	Black	/	Violet	Yellow	

Output cable for ERN 1381 inside the motor housing ID 667343-01	17-pin M23 flange socket				12-pin PCB connector									
	Power supply				Incremental signals						Other signals			
	7	1	10	4	15	16	12	13	3	2	5	6	8/9/11/ 14/17	
	2a	2b	1a	1b	6b	6a	5b	5a	4b	4a	/	/	3a/3b	
	U _P	Sensor ¹⁾ U _P	0V	Sensor ¹⁾ 0V	A+	A-	B+	B-	R+	R-	T+ ²⁾	T- ²⁾	Vacant	
	Brown/ Green	Blue	White/ Green	White	Brown	Green	Gray	Pink	Red	Black	Brown ²⁾	White ²⁾	/	

Cable shield connecting with housing; U_P = Power supply voltage ¹⁾ **LIDA 2xx**: vacant ²⁾ Only for the output cable inside the motor housing
Sensor: The sense line is connected in the encoder with the corresponding power line.
 Vacant pins or wires must not be used!

TTL incremental signals

HEIDENHAIN encoders with the TTL interface incorporate electronics that digitize sinusoidal scanning signals with or without interpolation.

The **incremental signals** are output as the square-wave pulse trains U_{a1} and U_{a2} with a 90° elec. phase shift. The **reference mark signal** consists of one or more reference pulses U_{a0} , which are gated with the incremental signals. In addition, the integrated electronics generate the **inverted signals** $\overline{U_{a1}}$, $\overline{U_{a2}}$, and $\overline{U_{a0}}$ for noise-immune transmission. The illustrated sequence of output signals—with U_{a2} lagging U_{a1} —applies to the direction of motion shown in the dimension drawing.

The **fault detection signal** $\overline{U_{aS}}$ indicates malfunctions such as an interruption in the supply lines, failure of the light source, etc.

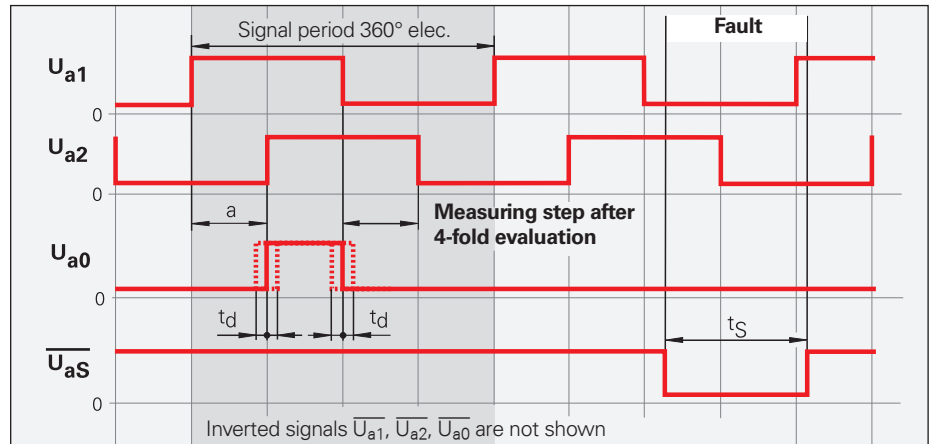

The distance between two successive edges of the incremental signals U_{a1} and U_{a2} through 1-fold, 2-fold, or 4-fold evaluation is one **measuring step**.



Further information:

Detailed descriptions of all available interfaces, as well as general electrical information, can be found in the *Interfaces of HEIDENHAIN Encoders* brochure.

Pin layout

	Power supply				Incremental signals						Other signals		
	12	2	10	11	5	6	8	1	3	4	7	/	9
	4	12	2	10	1	9	3	11	14	7	13	5/6/8	15
	2a	2b ¹⁾	1a	1b ¹⁾	6b	6a	5b	5a	4b	4a	3a	3b	/
	U_P	Sensor U_P	0V	Sensor 0V	U_{a1}	$\overline{U_{a1}}$	U_{a2}	$\overline{U_{a2}}$	U_{a0}	$\overline{U_{a0}}$	$\overline{U_{aS}}$ ¹⁾	Vacant	Vacant ²⁾
	Brown/ Green	Blue	White/ Green	White	Brown	Green	Gray	Pink	Red	Black	Violet	/	Yellow

Cable shield connected to housing; U_P = Power supply voltage







Sensor: The sense line is connected in the encoder with the corresponding power line.

Vacant pins or wires must not be used!

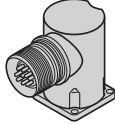
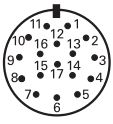

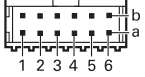

¹⁾ **ERO 14xx:** vacant

²⁾ **Exposed linear encoders:** conversion from TTL to 11 μA_{PP} for the PWT, otherwise not assigned

Pin layout

Output cable for ERN 1321 inside the motor ID 667343-01				17-pin M23 flange socket				12-pin PCB connector					
													
	Power supply				Incremental signals						Other signals		
	7	1	10	4	15	16	12	13	3	2	5	6	8/9/11/ 14/17
	2a	2b	1a	1b	6b	6a	5b	5a	4b	4a	/	/	3a/3b
	U_P	Sensor U_P	0V	Sensor 0V	U_{a1}	$\overline{U_{a1}}$	U_{a2}	$\overline{U_{a2}}$	U_{a0}	$\overline{U_{a0}}$	$T+^{1)}$	$T-^{1)}$	Vacant
	Brown/ Green	Blue	White/ Green	White	Brown	Green	Gray	Pink	Red	Black	Brown ¹⁾	White ¹⁾	/

ERN 421 pin layout

12-pin M16 flange socket (female)												
												
	Power supply				Incremental signals						Other signals	
	M	B	K	L	E	F	H	A	C	D	G	J
	U_P	Sensor U_P	0V	Sensor 0V	U_{a1}	$\overline{U_{a1}}$	U_{a2}	$\overline{U_{a2}}$	U_{a0}	$\overline{U_{a0}}$	$\overline{U_{aS}}$	Vacant
	Brown/ Green	Blue	White/ Green	White	Brown	Green	Gray	Pink	Red	Black	Violet	Yellow

Cable shield connected to housing; U_P = Power supply voltage

Sensor: The sense line is connected in the encoder with the corresponding power line.

Vacant pins or wires must not be used!

¹⁾ Only with output cables inside the motor housing

HTL, HTLs incremental signals

HEIDENHAIN encoders with the HTL interface incorporate electronics that digitize sinusoidal scanning signals with or without interpolation.

The **incremental signals** are output as the square-wave pulse trains U_{a1} and U_{a2} with a 90° elec. phase shift. The **reference mark signal** consists of one or more reference pulses U_{a0} , which are gated with the incremental signals. In addition, the integrated electronics generate the **inverted signals** $\overline{U_{a1}}$, $\overline{U_{a2}}$, and $\overline{U_{a0}}$ for noise-immune transmission (not with HTLs). The illustrated sequence of output signals—with U_{a2} lagging U_{a1} —applies to the direction of motion shown in the dimension drawing.

The **fault detection signal** $\overline{U_{aS}}$ indicates malfunctions such as failure of the light source, etc.

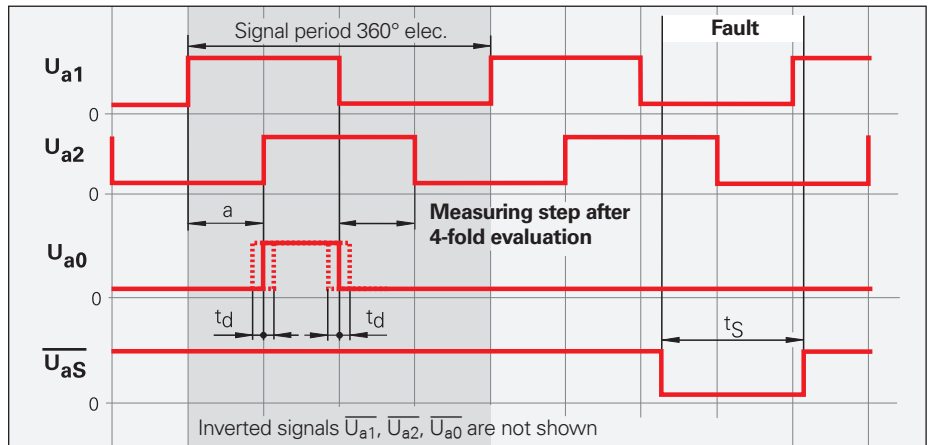

The distance between two successive edges of the incremental signals U_{a1} and U_{a2} through 1-fold, 2-fold, or 4-fold evaluation is one **measuring step**.



Further information:

Detailed descriptions of all available interfaces, as well as general electrical information, can be found in the *Interfaces of HEIDENHAIN Encoders* brochure.

ERN 431 pin layout

12-pin M16 flange socket (female)												
Power supply				Incremental signals						Other signals		
M	B	K	L	E	F	H	A	C	D	G	J	
U_P	Sensor U_P	0V	Sensor 0V	U_{a1}	$\overline{U_{a1}}$	U_{a2}	$\overline{U_{a2}}$	U_{a0}	$\overline{U_{a0}}$	$\overline{U_{aS}}$	Vacant	
Brown/ Green	Blue	White/ Green	White	Brown	Green	Gray	Pink	Red	Black	Violet	Yellow	

Cable shield connected to housing; U_P = Power supply voltage

Sensor: The sense line is connected in the encoder with the corresponding power line.

Vacant pins or wires must not be used!

Commutation signals for block commutation

The **block commutation signals U, V, and W** are obtained from three separate absolute tracks. They are transmitted as square-wave signals in TTL levels.

The **ERN 1x23** and **ERN 1326** are rotary encoders with commutation signals for block commutation.



Further information:

Detailed descriptions of all available interfaces, as well as general electrical information, can be found in the *Interfaces of HEIDENHAIN Encoders* brochure.

ERN 1123, ERN 1326 pin layout

17-pin M23 flange socket				16-pin PCB connector				15-pin PCB connector			
	Power supply				Incremental signals						
	7	1	10	11	15	16	12	13	3	2	
	1b	2b	1a	/	5b	5a	4b	4a	3b	3a	
	13	/	14	/	1	2	3	4	5	6	
	U_P	Sensor U_P	0V	Internal shield	U_{a1}	\overline{U}_{a1}	U_{a2}	\overline{U}_{a2}	U_{a0}	\overline{U}_{a0}	
	Brown/ Green	Blue	White/ Green	/	Green/ Black	Yellow/ Black	Blue/Black	Red/Black	Red	Black	

Other signals							
	4	5	6	14	17	9	8
	2a	8b	8a	6b	6a	7b	7a
	/	7	8	9	10	11	12
	\overline{U}_{aS}	U	\overline{U}	V	\overline{V}	W	\overline{W}
	White	Green	Brown	Yellow	Violet	Gray	Pink

Cable shield connected to housing;
 U_P = Power supply voltage
Sensor: The sense line is connected in the encoder with the corresponding power line (only with ERN 1326).
 Vacant pins or wires must not be used!

Pin layout for ERN 1023

Power supply		Incremental signals							Other signals					
	U_P	0V	U_{a1}	\overline{U}_{a1}	U_{a2}	\overline{U}_{a2}	U_{a0}	\overline{U}_{a0}	U	\overline{U}	V	\overline{V}	W	\overline{W}
	White	Black	Red	Pink	Olive Green	Blue	Yellow	Orange	Beige	Brown	Green	Gray	Light Blue	Violet

Cable shield connected to housing;
 U_P = Power supply voltage
 Vacant pins or wires must not be used!

Commutation signals for sine commutation

The **commutation signals C and D** are obtained from the Z1 track and are equal to one sine or cosine period per revolution. They have a signal amplitude of $1 V_{PP}$ (typical) at $1 \text{ k}\Omega$.

The input circuit of the subsequent electronics is the same as that of the $\sim 1 V_{PP}$ interface. However, the required terminating resistance Z_0 is $1 \text{ k}\Omega$ instead of 120Ω .









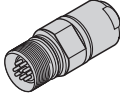

The **ERN 1387** is a rotary encoder with output signals for sinusoidal commutation.

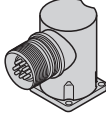

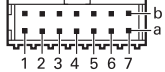

Further information:

Detailed descriptions of all available interfaces, as well as general electrical information, can be found in the *Interfaces of HEIDENHAIN Encoders* brochure.

Pin layout

17-pin M23 coupling or flange socket						14-pin PCB connector					
											
Power supply					Incremental signals						
	7	1	10	4	11	15	16	12	13	3	2
	1b	7a	5b	3a	/	6b	2a	3b	5a	4b	4a
	U_P	Sensor U _P	0V	Sensor 0V	Internal shield	A+	A-	B+	B-	R+	R-
	Brown/ Green	Blue	White/ Green	White	/	Green/ Black	Yellow/ Black	Blue/Black	Red/Black	Red	Black

Other signals						
	14	17	9	8	5	6
	7b	1a	2b	6a	/	/
	C+	C-	D+	D-	T+ ¹⁾	T- ¹⁾
	Gray	Pink	Yellow	Violet	Green	Brown

Cable shield connected to housing;

U_P = Power supply voltage; **T** = Temperature

Sensor: The sense line is connected internally to the respective the power line.

Vacant pins or wires must not be used!

¹⁾ Only with output cables inside the motor housing

EnDat position values

The EnDat interface is a digital, **bidirectional** interface for encoders. It is capable of outputting **position values**, reading information stored in the encoder, updating this information, and storing new information. Because the interface uses **serial transmission**, only **four signal lines** are required. The data (DATA) are transmitted in **synchronism** with the CLOCK signal from the subsequent electronics. The type of transmission (position values, parameters, diagnostics, etc.) is selected via mode commands sent to the encoder by the subsequent electronics. Some functions are available only with EnDat 2.2 mode commands.

Ordering designation	Command set	Incremental signals
EnDat01 EnDat H EnDat T	EnDat 2.1 or EnDat 2.2	1 V _{PP} HTL TTL
EnDat21		–
EnDat02	EnDat 2.2	1 V _{PP}
EnDat22	EnDat 2.2	–

Versions of the EnDat interface

Further information:

Detailed descriptions of all available interfaces, as well as general electrical information, can be found in the *Interfaces of HEIDENHAIN Encoders* brochure.

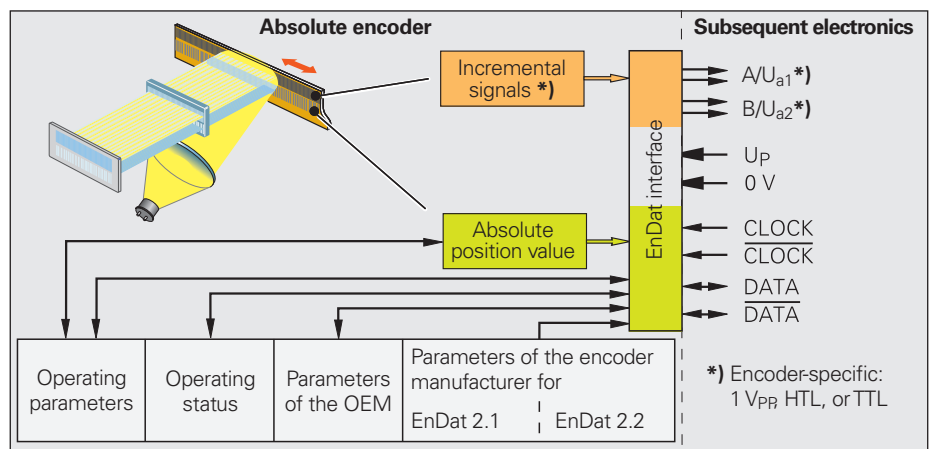

*) Encoder-specific: 1 V_{PP} HTL, or TTL

Pin layout for EnDat01/EnDat02

17-pin M23 coupling or flange socket						12-pin PCB connector				15-pin PCB connector															
Power supply						Incremental signals ¹⁾				Serial data transmission															
7		1		10		15		16		12		13		14		17		8		9					
12		6a		4b		3a		/		2a		5b		4a		3b		6b		1a		2b		5a	
15		11		14		12		/		1		2		3		4		7		8		9		10	
Up		Sensor Up		0V		Sensor 0V		Internal shield		A+		A-		B+		B-		DATA		DATA		CLOCK		CLOCK	
Brown/ Green		Blue		White/ Green		White		/		Green/ Black		Yellow/ Black		Blue/ Black		Red/ Black		Gray		Pink		Violet		Yellow	

Other signals	
5	6
/	/
/	/
T ⁺ ²⁾	T ⁻ ²⁾
Brown ²⁾	White ²⁾

Cable shield connected to housing; **Up** = Power supply voltage; **T** = Temperature
Sensor: The sense line is connected in the encoder with the corresponding power line.

Vacant pins or wires must not be used!

¹⁾ Only with the ordering designations EnDat 01 and EnDat 02

²⁾ Only with output cables inside the motor housing

EnDat22 pin layout

8-pin M12 coupling or flange socket					9-pin M23 SpeedTEC angle flange socket					
16-pin PCB connector					15-pin PCB connector					
	Power supply				Serial data transmission				Other signals	
	8	2	5	1	3	4	7	6	/	/
	3	7	4	8	5	6	1	2	/	/
	1b	6a	4b	3a	6b	1a	2b	5a	8a	8b
	13	11	14	12	7	8	9	10	5	6
	U_P	Sensor U_P¹⁾	0V	Sensor 0V¹⁾	DATA	DATA	CLOCK	CLOCK	T²⁾	T⁻²⁾
	Brown/ Green	Blue	White/ Green	White	Gray	Pink	Violet	Yellow	Brown	Green

Cable shield connected to housing; **U_P** = Power supply voltage; **T** = Temperature

Sensor: The sense line is connected in the encoder with the corresponding power line.

Vacant pins or wires must not be used!

¹⁾ **ECI 1118 EnDat22:** vacant ²⁾ Only EnDat22, except ECI 1118

Pin layout for EBI 135/EBI 1135/EBI 4010

15-pin PCB connector										
8-pin M12 flange socket					9-pin M23 SpeedTEC angle flange socket					
	Power supply				Serial data transmission				Other signals ¹⁾	
	13	11	14	12	7	8	9	10	5	6
	8	2	5	1	3	4	7	6	/	/
	3	7	4	8	5	6	1	2	/	/
	U_P	U_{BAT}	0V²⁾	0V_{BAT}²⁾	DATA	DATA	CLOCK	CLOCK	T+	T-
	Brown/ Green	Blue	White/ Green	White	Gray	Pink	Violet	Yellow	Brown	Green

U_P = Power supply voltage; **U_{BAT}** = External backup battery (incorrect polarity can result in damage to the encoder)

Vacant pins or wires must not be used!

¹⁾ Only with EBI 135

²⁾ Connected inside encoder

Pin layout

HMC 6 flange socket								
16-pin PCB connector				15-pin PCB connector				
Encoder								
	Power supply		Serial data transmission				Other signals	
	1	2	3	4	5	6	/	/
	1b	4b	6b	1a	2b	5a	8a	8b
	13	14	7	8	9	10	5	6
	U_P	0V	DATA	DATA	CLOCK	CLOCK	T⁺¹⁾	T⁻¹⁾
	Brown/Green	White/Green	Gray	Pink	Violet	Yellow	Brown	Green
Motor								
	Brake		Power					
	7	8	A	B	C	D	E	
	BRAKE-	BRAKE+	U	V	W	/	PE	
	White	White/Black	Blue	Brown	Black	/	Yellow/Green	

Outer shield of the encoder output cable on housing of communication element **K**.

Vacant pins or wires must not be used!

¹⁾ Except ECI 1118

DRIVE-CLiQ interface

HEIDENHAIN encoders with the code letter S after the model designation are suitable for connection to Siemens controls with the **DRIVE-CLiQ interface**

- Ordering designation: DQ01











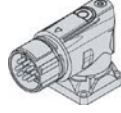
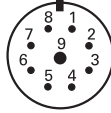

DRIVE-CLiQ is a registered trademark of Siemens AG.

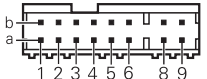

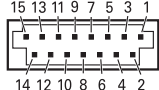
Further information:

Detailed descriptions of all available interfaces, as well as general electrical information, can be found in the *Interfaces of HEIDENHAIN Encoders* brochure.

Siemens pin layout

8-pin M12 flange socket		9-pin M23 SpeedTEC angle flange socket									
											
16-pin PCB connector		15-pin PCB connector									
											
	Power supply			Serial data transmission				Other signals ¹⁾			
	M12	8	2	1	5	3	4	7	6	/	/
	M23	3	7	8	4	5	6	1	2	/	/
	16	1b	6a	3a	4b	6b	1a	2b	5a	8a	8b
	15	13	11	12	14	7	8	9	10	5	6
	-	-	Up	0V	RXP	RXN	TXP	TXN	T+ ²⁾	T- ²⁾	
	Brown/ Green	Blue	White	White/ Green	Gray	Pink	Violet	Yellow	Brown	Green	

Cable shield connected to housing; **Up** = Power supply voltage

Vacant pins or wires must not be used!

Output cables with a cable length > 0.5 m require strain relief for the cable

¹⁾ Only with output cables inside the motor housing

²⁾ Connections for external temperature sensor; evaluation optimized for the KTY 84-130 (see *Temperature measurement in motors*)

SpeedTEC is a registered trademark of TE Connectivity Industrial GmbH.

EBI 1135/EBI 135/EBI 4010: external backup battery

The multiturn functionality of the EBI 1135, EBI 135, and EBI 4000 is implemented by means of a revolution counter. In order for the absolute position information to still be available after loss of power, the EBI must be operated with an external backup battery.

A lithium thionyl chloride battery with 3.6 V and 1200 mAh is recommended for the backup battery. The typical battery service life is over nine years (EBI 1135/135) or six years (EBI 4010) under the right conditions (two ten-hour shifts under normal operation, battery temperature of 25 °C, and typical self-discharging). In order for this to be achieved, the main power supply (U_P) must be connected to the encoder during or immediately after connection of the backup battery so that the encoder is fully initialized after being completely without power. Otherwise, the encoder will consume a significantly higher amount of battery current until main power is first supplied.

To avoid damage to the encoder, ensure the correct polarity of the backup battery. HEIDENHAIN recommends operating each encoder with its own backup battery.

If the application requires compliance with DIN EN 60086-4 or UL 1642, then an appropriate protective circuit is required for protection from wiring errors.

If the voltage of the backup battery falls below certain thresholds, the encoder will set warning or error messages that are transmitted via the EnDat interface:

- **“Battery charge” warning**
 $\leq 2.8\text{ V} \pm 0.2\text{ V}$
 in normal operating mode
- **“M Power interruption” error message**
 $\leq 2.2\text{ V} \pm 0.2\text{ V}$
 in battery-buffered mode (encoder must be re-referenced)

Low battery current continues to flow even during normal operation of the EBI. The amount of current depends on the operating temperature.

Please note:

Compliance with EnDat Specification 297403 and EnDat Application Notes 722024, Chapter 13, *Battery-buffered encoders*, is required for correct control of the encoder.

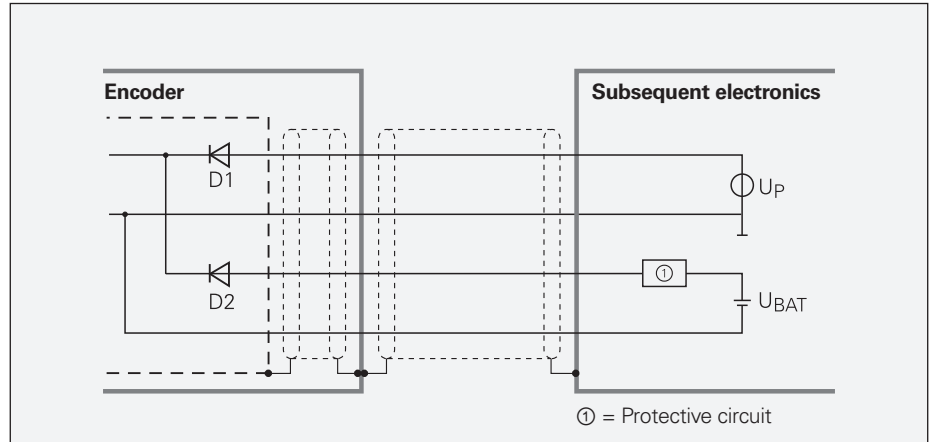

Backup battery connection

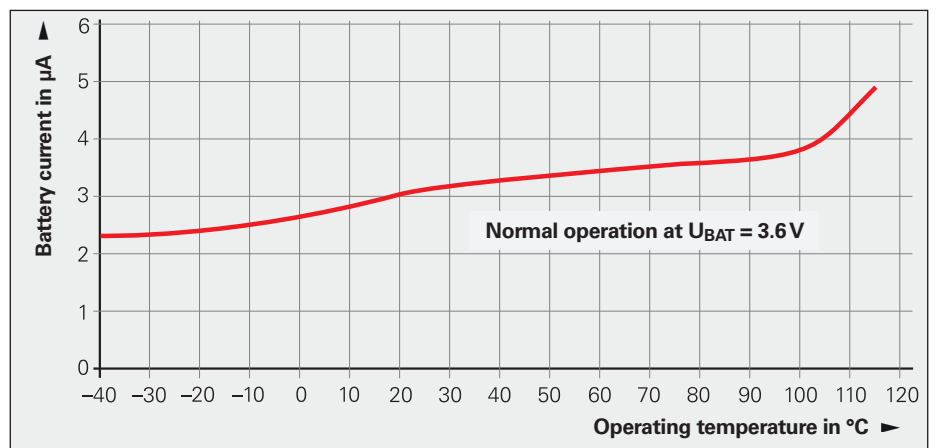

EBI 1135/135: typical discharge current during normal operation ($U_B = 3.6\text{ V}$)

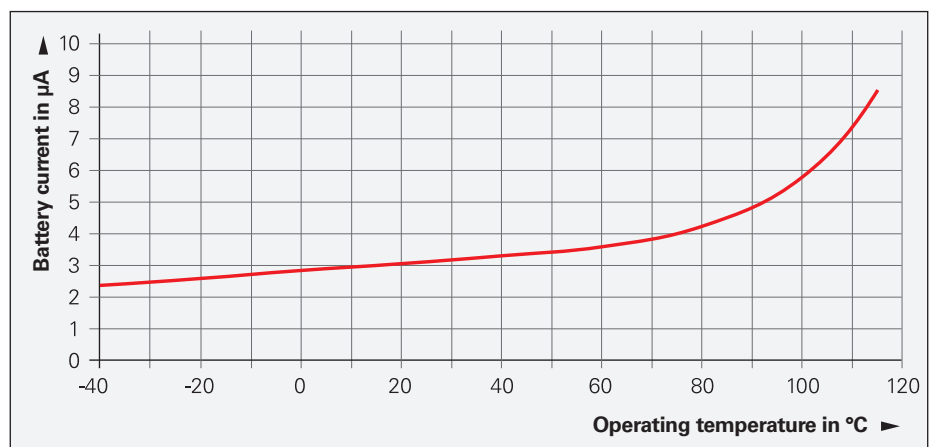

EBI 4010: typical discharge current during normal operation ($U_{BAT} = 3.6\text{ V}$)

SSI position values

The **position value** is transmitted starting with the most significant bit (MSB) over the data lines (DATA) in synchronism with a clock signal (CLOCK) provided by the control. The SSI standard data word length for singleturn encoders is 13 bits, and for multiturn encoders 25 bits. In addition to the absolute position values, **incremental signals** can be output as well. For a description of the signals, see $1 V_{PP}$ incremental signals.

The following **functions** can be activated via programming inputs:

- **Direction of rotation**
- **Zeroing** (setting to zero)

Data transmission

$T = 1$ to $10 \mu\text{s}$
 t_{cal} See Specifications
 $t_1 \leq 0.4 \mu\text{s}$
 (without cable)
 $t_2 = 17$ to $20 \mu\text{s}$
 $t_R \geq 5 \mu\text{s}$
 $n =$ Data word length
 13 bits for ECN/ROC
 25 bits for EQN/ROQ

$\overline{\text{CLOCK}}$ and $\overline{\text{DATA}}$ not shown

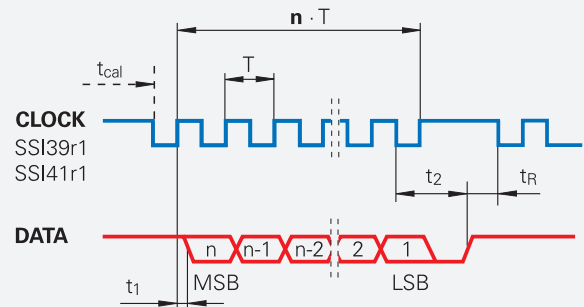

Further information:

Detailed descriptions of all available interfaces, as well as general electrical information, can be found in the *Interfaces of HEIDENHAIN Encoders* brochure.

Pin layout

17-pin M23 coupling

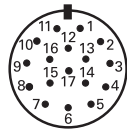
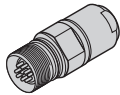

	Power supply					Incremental signals				Serial data transmission				Other signals	
	7	1	10	4	11	15	16	12	13	14	17	8	9	2	5
	U_P	Sensor U_P	0V	Sensor 0V	Internal shield ¹⁾	A+	A-	B+	B-	DATA	$\overline{\text{DATA}}$	CLOCK	$\overline{\text{CLOCK}}$	Dir. of rotation	Zeroing
	Brown/ Green	Blue	White/ Green	White	/	Green/ Black	Yellow/ Black	Blue/ Black	Red/ Black	Gray	Pink	Violet	Yellow	Black	Green

Shield lies on housing; U_P = Power supply voltage

Sensor: With a 5 V supply voltage, the sense line is connected in the encoder with the corresponding power line.

¹⁾ Vacant with the ECN/EQN 10xx and ROC/ROQ 10xx

Cables and connecting elements

General information and dimensions

Plastic-insulated connector:

connecting element with coupling ring, available with male or female contacts (see symbols)

Symbols

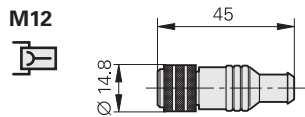

M12 right-angle connector

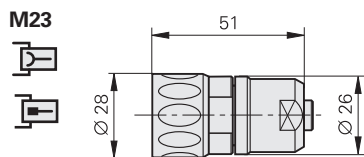
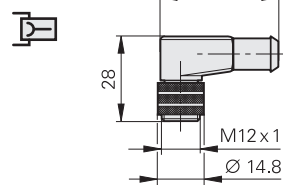

Plastic-insulated coupling: connecting element with outside thread, available with male or female contacts (see Symbols).

Symbols



Mounted coupling with central fastening

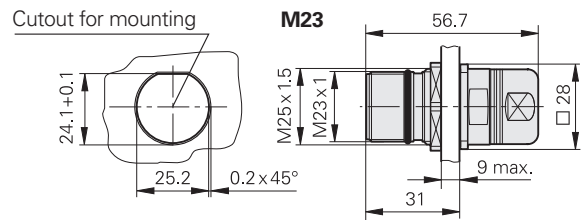
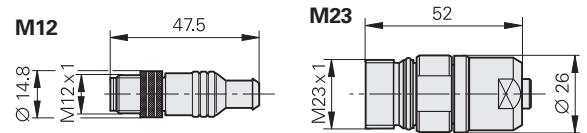

Mounted coupling with flange

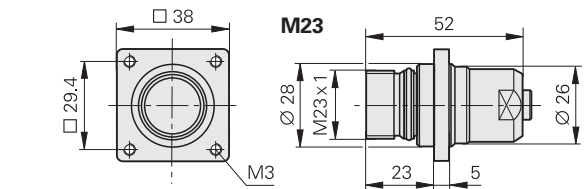

Flange socket with external thread; is permanently mounted onto a housing; available with male or female contacts.

Symbols

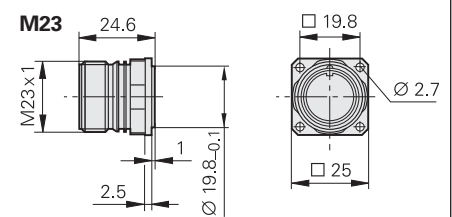

HMC 6

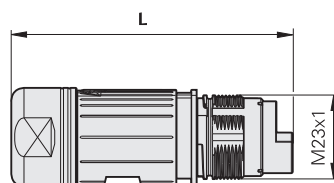
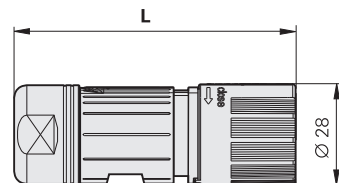
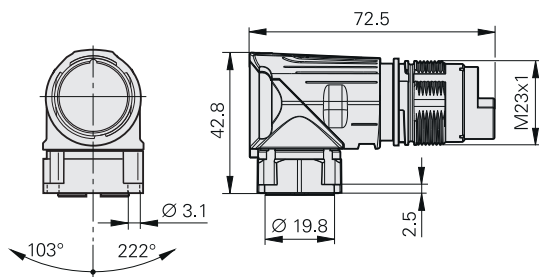

	L
Ø 9.5 mm – Ø 14.5 mm	78
Ø 14 mm – Ø 17 mm	80.5

	L
Ø 9.5 mm – Ø 14.5 mm	78
Ø 14 mm – Ø 17 mm	80.5

Required mating dimensions for flange socket

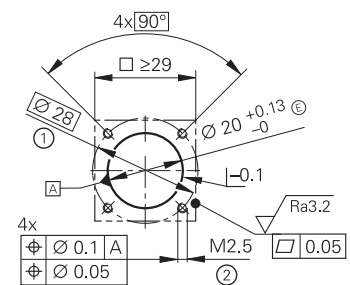

- ① = Bolt circle diameter
- ② = At least 4 mm load-bearing thread length

mm



Tolerancing ISO 8015

ISO 2768 - m H

≤ 6 mm: ±0.2 mm

M12 flange socket

for the EnDat21/22 interface, with output cable for inside the motor housing

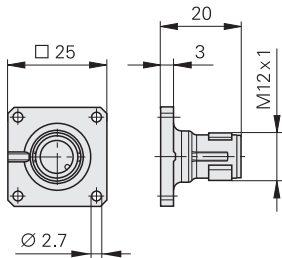

M23 angle flange socket

(rotatable) with output cable inside the motor

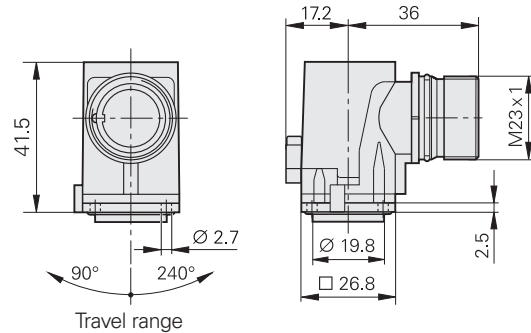

M12 flange socket

for the DRIVE-CLiQ interface, with output cable for inside the motor housing

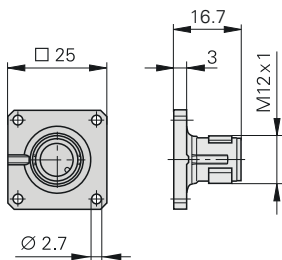

DRIVE-CLiQ is a registered trademark of Siemens AG.

M23 SpeedTEC angle flange socket

(rotatable) with output cable inside the motor

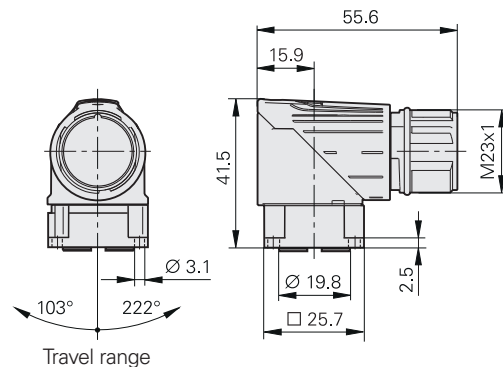

Required mating dimensions for M12 and M23 flange socket

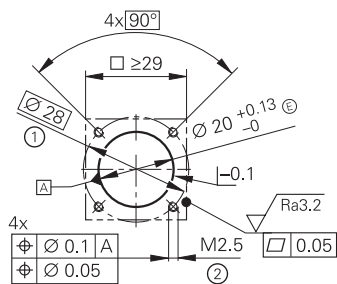

- ① = Bolt circle diameter
- ② = At least 4 mm load-bearing thread length

Output cables with a SpeedTEC angle flange socket always come with a mounted O-ring for vibration protection. As a result, they can be used as connecting cables (VBK) with either a threaded connector (with O-ring) or a SpeedTEC connector (O-ring must be removed).

SpeedTEC is a registered trademark of TE Connectivity Industrial GmbH.

D-sub connector for HEIDENHAIN controls, counters, and IK absolute-value cards

Symbols

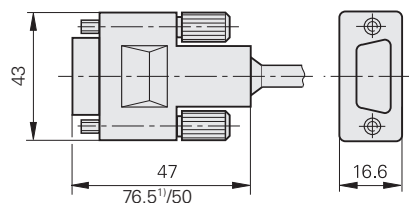

1) Interface electronics integrated into the connector

The **pin numbering** on connectors is in the direction opposite to that on couplings or flange sockets, regardless of whether the connecting elements have





When connected, the **protection class** of the connecting elements is equivalent to IP67 (D-sub connector: IP50; EN 60529). When not connected, there is no protection.

Accessories for M23 flange sockets and M23 mounted couplings

Threaded dust cap made of metal
ID 219926-01

Output cables inside the motor housing

Output cables inside the motor housing Cable diameters: 4.5 mm or 3.7 mm; TPE single wires with heat shrink tubing or braided sleeve				With PCB connector and 17-pin M23 angle flange socket, and wires for temperature sensor (cross-linked polyolefin 2 x 0.25 mm ²)	With PCB connector and 9-pin M23 angle flange socket, and wires for temperature sensor (TPE 2 x 0.16 mm ²)
Rotary encoder	Interface	PCB connector	Crimp sleeve		
ECI 119	EnDat01	15-pin	-	-	-
ECI 119	EnDat22	15-pin	-	-	1120947-xx ^{1) 4)} EPG 1 x (4 x 0.06 mm ²) + 4 x 0.06 mm ²
EBI 135	EnDat22	15-pin	-	-	-
ECI 1119 EQI 1131	EnDat22	15-pin	-	-	-
ECI 1118	EnDat22	15-pin	-	-	-
EBI 1135	EnDat22	15-pin	-	-	-
ECI 1319 EQI 1331 EBI 1335	EnDat22	16-pin or 12-pin + 4-pin	Ø 6 mm	-	1120948-xx ⁴⁾ EPG 1 x (4 x 0.06 mm ²) + 4 x 0.06 mm ²
ECI 1319 S EQI 1331 S ECN 1324 S EQN 1336 S	DRIVE-CLiQ	16-pin	Ø 6.1 mm	-	1120945-xx EPG 2 x (2 x 0.06 mm ²) + 4 x 0.06 mm ²
ECN 1113 EQN 1125	EnDat01	15-pin	Ø 4.5 mm	606079-xx EPG 16 x 0.06 mm ²	-
ECN 1123 EQN 1135	EnDat22	15-pin	Ø 4.5 mm	-	-
ECN 1123 S EQN 1135 S	DRIVE-CLiQ	15-pin	Ø 4.5 mm	-	-
ECN 1313 EQN 1325	EnDat01	12-pin	Ø 6 mm	332201-xx EPG 16 x 0.06 mm ²	-

Attention: For output cables, conformity with the EMC Directive must be ensured in the complete system. The shield connection must be implemented on the motor.

SpeedTEC is a registered trademark of TE Connectivity Industrial GmbH.

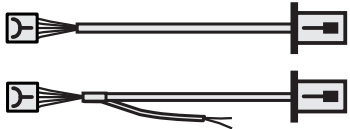
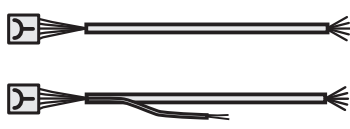
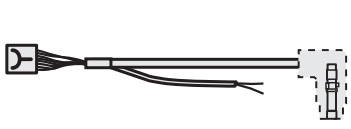
<p>With PCB connector and 8-pin M12 flange socket (TPE single wires with braided sleeve without shield), and wires for temperature sensor (TPE 2 x 0.16 mm²)</p>  <p>With wires for temperature sensor [Ⓟ]</p>	<p>With PCB connector and stripped or unstripped cable end, and wires for temperature sensor (TPE 2 x 0.16 mm²)</p>  <p>With wires for temperature sensor [Ⓟ]</p>	<p>With PCB connector and contact insert for HMC 6 hybrid connecting element, and wires for temperature sensor (TPE 2 x 0.16 mm²)</p> 
-	640067-xx ¹⁾ EPG 16 x 0.06 mm ²	-
-	825855-xx ¹⁾ EPG 4 x 2 x 0.16 mm ²	1072652-xx ¹⁾ EPG 1 x (4 x 0.06 mm ²) + 4 x 0.06 mm ²
-	1116479-xx ¹⁾ [Ⓟ] EPG 1 x (4 x 0.06 mm ²) + 4 x 0.06 mm ²	-
1119952-xx [Ⓟ] TPE 8 x 0.16 mm ²	1119958-xx [Ⓟ] TPE 8 x 0.16 mm ²	1072652-xx ¹⁾ EPG 1 x (4 x 0.06 mm ²) + 4 x 0.06 mm ²
805320-xx TPE 6 x 0.16 mm ²	735784-xx ²⁾ TPE 6 x 0.16 mm ²	
804201-xx TPE 8 x 0.16 mm ²	640055-xx ²⁾ TPE 8 x 0.16 mm ²	-
1117280-xx [Ⓟ] TPE 8 x 0.16 mm ²	1108076-xx [Ⓟ] EPG 1 x (4 x 0.06 mm ²) + 4 x 0.06 mm ² 1100199-xx TPE 8 x 0.16 mm ² 1143830-xx [Ⓟ] TPE 8 x 0.16 mm ²	1035387-xx EPG 1 x (4 x 0.06 mm ²) + 4 x 0.06 mm ²
-	605090-xx EPG 16 x 0.06 mm ²	-
1117412-xx [Ⓟ] TPE 8 x 0.16 mm ²	1108078-xx [Ⓟ] EPG 1 x (4 x 0.06 mm ²) + 4 x 0.06 mm ²	1035857-xx EPG 1 x (4 x 0.06 mm ²) + 4 x 0.06 mm ²
1217143-xx [Ⓟ] TPE 2 x 0.16 mm ²	-	-
-	332202-xx EPG 16 x 0.06 mm ²	-

¹⁾ With cable clamp for shield connection

²⁾ Single wires with heat shrink tubing, without shield



³⁾ Note the max. temperature, see the *Interfaces of HEIDENHAIN Encoders* brochure

⁴⁾ SpeedTEC right-angle flange socket (male) with O-ring for vibration protection (for threaded connector with O-ring; for SpeedTEC connector, remove O-Ring)



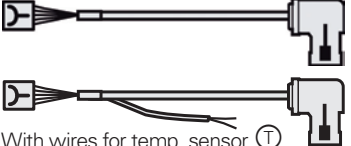

Further information:

For more information about HMC 6, please refer to the *HMC 6 Product Information* document.

Output cables inside the motor housing Cable diameters: 4.5 mm or 3.7 mm; TPE single wires with heat shrink tubing or braided sleeve				With PCB connector and 17-pin M23 angle flange socket, and wires for temperature sensor (cross-linked polyolefin 2 x 0.25 mm ²)	With PCB connector and 9-pin M23 angle flange socket, and wires for temperature sensor (TPE 2 x 0.16 mm ²)
Rotary encoder	Interface	PCB connector	Crimp sleeve		
ECN 1324 S EQN 1336 S	DRIVE-CLiQ	16-pin or 12-pin + 4-pin	Ø 6 mm	–	1120945-xx ⁴⁾ EPG 2 x (2 x 0.06 mm ²) + 4 x 0.06 mm ²
ECN 1325 EQN 1337	EnDat22	16-pin or 12-pin + 4-pin	Ø 6 mm	–	1120948-xx ⁴⁾ EPG 1 x (4 x 0.06 mm ²) + 4 x 0.06 mm ²
ERN 1123	TTL	15-pin	–	–	–
ERN 1321 ERN 1381	TTL 1 V _{PP}	12-pin	Ø 6 mm	667343-xx EPG 16 x 0.06 mm ²	–
ERN 1326	TTL	16-pin	Ø 6 mm	–	–
ERN 1387	1 V _{PP}	14-pin	Ø 6 mm	332199-xx EPG 16 x 0.06 mm ²	–
ERO 1225 ERO 1285	TTL 1 V _{PP}	12-pin	Ø 4.5 mm	–	–
ERO 1420 ERO 1470 ERO 1480	TTL TTL 1 V _{PP}	12-pin	Ø 4.5 mm	–	–
ECI 4010 EBI 4010	EnDat22	15-pin	Ø 4.5 mm	–	1121041-xx ⁴⁾ EPG 1 x (4 x 0.06 mm ²) + 4 x 0.06 mm ²
					1120940-xx ⁴⁾  EPG 1 x (4 x 0.06 mm ²) + 4 x 0.06 mm ²
ECI 4090 S	DRIVE-CLiQ	15-pin	Ø 4.5 mm	–	1125408-xx ⁴⁾ EPG 2 x (2 x 0.06 mm ²) + 4 x 0.06 mm ²
					1125403-xx ⁴⁾  EPG 2 x (2 x 0.06 mm ²) + 4 x 0.06 mm ²

Attention: For output cables, conformity with the EMC Directive must be ensured in the complete system.
The shield connection must be implemented on the motor.

DRIVE-CLiQ is a registered trademark of Siemens AG.
SpeedTEC is a registered trademark of TE Connectivity Industrial GmbH.

<p>With PCB connector and 8-pin M12 flange socket (TPE single wires with braided sleeve without shield), and wires for temperature sensor (TPE 2 x 0.16 mm²)</p> 	<p>With PCB connector and stripped or unstripped cable end, and wires for temperature sensor (TPE 2 x 0.16 mm²)</p>  <p>With wires for temperature sensor ①</p>	<p>With PCB connector and contact insert for HMC 6 hybrid connecting element, and wires for temperature sensor (TPE 2 x 0.16 mm²)</p> 
<p>1181373-xx⁵⁾ EPG 2 x (2 x 0.06 mm²) + 4 x 0.06 mm²</p>	<p>–</p>	<p>–</p>
<p>1117280-xx TPE 8 x 0.16 mm²</p>	<p>1108076-xx ① EPG 1 x (4 x 0.06 mm²) + 4 x 0.06 mm²</p> <p>1100199-xx TPE 8 x 0.16 mm²</p> <p>1143830-xx TPE 8 x 0.16 mm²</p>	<p>1035387-xx EPG 1 x (4 x 0.06 mm²) + 4 x 0.06 mm²</p>
<p>–</p>	<p>738976-xx²⁾ TPE 14 x 0.16 mm²</p>	<p>–</p>
<p>–</p>	<p>333276-xx EPG 16 x 0.06 mm²</p>	<p>–</p>
<p>–</p>	<p>341369-xx EPG 16 x 0.06 mm²</p>	<p>–</p>
<p>–</p>	<p>332200-xx EPG 16 x 0.06 mm²</p>	<p>–</p>
<p>–</p>	<p>372164-xx³⁾ PUR [4(2 x 0.05 mm²) + (4 x 0.16 mm²)]</p>	<p>–</p>
<p>–</p>	<p>346439-xx³⁾ PUR [4(2 x 0.05 mm²) + (4 x 0.16 mm²)]</p>	<p>–</p>
<p>–</p>	<p>–</p>	<p>–</p>
<p>–</p>	<p>–</p>	<p>–</p>

¹⁾ With cable clamp for shield connection

²⁾ Single wires with heat shrink tubing, without shield

³⁾ Note the max. temperature, see the *Interfaces of HEIDENHAIN Encoders* brochure

⁴⁾ SpeedTEC angle flange socket (male) with O-ring for vibration protection (for threaded connector with O-ring; for SpeedTEC connector, remove O-ring)

⁵⁾ EPG cable with one-sided shield connection











Further information:

For more information about HMC 6, please refer to the *HMC 6 Product Information* document.

PUR adapter cables and connecting cables 4(2 x 0.14 mm ²) + (4 x 0.5 mm ²); A _P = 0.5 mm ²		Ø 8 mm	~ 1V _{PP} □ TTL
Adapter cable with 15-pin connector (female) and 15-pin D-sub connector (female) for the TNC			310199-xx
Adapter cable with 15-pin connector (female) and 15-pin D-sub connector (male) for the PWM 21/EIB 741			310196-xx
Connecting cable with connector (female) and coupling (male)			298401-xx
Connecting cable with connector (female) and connector (male)			298399-xx
Connecting cable with connector (female)			309777-xx
Cable only			816317-xx
Mating element on connecting cable; fits encoder connector	Connector (female) for cable Ø 8 mm 		291697-05
Connector on connecting cable for connection to subsequent electronics	Connector (male) for cable Ø 8 mm Ø 6 mm 		291697-08 291697-07
Coupling on connecting cable	Coupling (male) for cable Ø 4.5 mm Ø 6 mm Ø 8 mm 		291698-14 291698-03 291698-04
Flange socket for mounting into the subsequent electronics	Flange socket (female) 		315892-08
Mounted couplings	With flange (female) Ø 6 mm Ø 8 mm 		291698-17 291698-07
	With flange (male) Ø 6 mm Ø 8 mm 		291698-08 291698-31
	With central fastening (male) Ø 6 mm to 10 mm 		741045-01
~ 1V_{PP}/11 µA_{PP} adapter connector for conversion from 1 V _{PP} to 11 µA _{PP} ; 12-pin M23 connector (female) and 9-pin M23 connector (male)			364914-01

A_P: Cross section of power supply lines

PUR adapter cables and connecting cables		EnDat without incremental signals		EnDat with SSI incremental signals
8-pin, Ø 3.7 mm:	$1(4 \times 0.06 \text{ mm}^2) + (4 \times 0.06 \text{ mm}^2); A_P = 2 \times 0.06 \text{ mm}^2$			
8-pin, Ø 6 mm:	$2(2 \times 0.09 \text{ mm}^2) + 2(2 \times 0.16 \text{ mm}^2); A_P = 2 \times 0.16 \text{ mm}^2$			
17-pin, Ø 8 mm:	$(4 \times 0.16 \text{ mm}^2) + 4(2 \times 0.16 \text{ mm}^2) + (4 \times 0.5 \text{ mm}^2); A_P = 2 \times 0.5 \text{ mm}^2$			
	Cable diameter	6 mm	3.7 mm	8 mm
Adapter cable with 15-pin connector (female) and 15-pin D-sub connector (female) for the TNC (position inputs)		1036521-xx	–	332115-xx
Adapter cable with 25-pin connector (female) and 25-pin D-sub connector (female) for the TNC (speed inputs)		1133104-xx	–	336376-xx 509667-xx
Adapter cable with 15-pin connector (female) and 15-pin D-sub connector (male) for the IK 215, PWM 21, EIB 741, etc.		1036526-xx	1118865-xx	324544-xx
Adapter cable with 15-pin right-angle connector (female) and 15-pin D-sub connector (male) for IK 215, PWM 21, EIB 741, etc.		1133855-xx	1118867-xx	–
Connecting cable with connector (female) and coupling (male)		1036372-xx	1118858-xx	323897-xx 340302-xx
Connecting cable with right-angle connector (female) and coupling (male)		1036386-xx	1118863-xx	–
Connecting cable with connector (female)		1129581-xx ¹⁾	–	309778-xx
Connecting cable with right-angle connector (female)		1133799-xx ¹⁾	–	–
Cable only		1150200-xx	–	816322-xx

Italics: Cable with pin layout for “speed encoder” input (MotEnc EnDat)

¹⁾ Connecting element must be suitable for the maximum clock frequency used



A_P: Cross section of power supply lines

For more adapter cables and connecting cables, see the *Cables and Connectors* brochure.

EnDat adapter cables

8-pin
M12

9-pin
M23

PUR adapter cables $2(2 \times 0.09 \text{ mm}^2) + 2(2 \times 0.16 \text{ mm}^2)$; $A_P = 2 \times 0.16 \text{ mm}^2$		EnDat without incremental signals	
With 9-pin M23 connector (female) and 8-pin M12 coupling (male)		Ø 6 mm Ø 8 mm	1136863-xx 1136874-xx
With 9-pin M23 connector (female) and 15-pin D-sub connector (female) for the PWM 21		Ø 6 mm	1173166-xx
With 9-pin M23 connector (female) and 25-pin, 2-row D-sub connector (female)		Ø 6 mm	1235648-xx

A_P : Cross section of power supply lines

HMC 6 connecting cable







PUR connecting cable Communication and supply: $2 \times (2 \times 0.09 \text{ mm}^2) + 2 \times 0.24 \text{ mm}^2$ Power and PE: $1 \times (3 \times 1.5 \text{ mm}^2) + 1 \times 1.5 \text{ mm}^2$		1.5 mm^2	4 mm^2
With hybrid connecting element and HMC 6 power wires		1188098-xx	1188099-xx



Further information:

For more information about HMC 6, please refer to the *HMC 6* Product Information document.

Siemens connecting cables

PUR adapter cables and connecting cables \varnothing 6.8 m; $2 \times (2 \times 0.17 \text{ mm}^2) + (2 \times 0.24 \text{ mm}^2)$; $A_p = 0.24 \text{ mm}^2$		
Adapter cable with 8-pin M12 connector (female) and RJ45 Siemens connector (IP67)		1094652-xx
Adapter cable with 8-pin M12 connector (female) and RJ45 Siemens connector (IP20)		1093042-xx
Adapter cable with 9-pin M23 SpeedTEC connector (female) and RJ45 Siemens connector (IP20)		1121546-xx
Adapter cable with 9-pin M23 connector (female) and RJ45 Siemens connector (IP20)		1117540-xx
Adapter cable with M23 SpeedTEC connector (female) and 8-pin M12 coupling (male)		1121536-xx
Connecting cable with M12 connector (female) and 8-pin M12 coupling (male)		822504-xx

A_p : Cross section of power supply lines

SpeedTEC is a registered trademark of TE Connectivity Industrial GmbH.

Interface electronics

Interface electronics from HEIDENHAIN adapt the encoder signals to the interface of the subsequent electronics. They are used when the subsequent electronics cannot directly process the output signals from HEIDENHAIN encoders, or when additional interpolation of the signals is necessary.

Input signals of the interface electronics

HEIDENHAIN interface electronics can be connected to encoders with 1 V_{PP} sinusoidal signals (voltage signals) or 11 μA_{PP} sinusoidal signals (current signals). Encoders with the EnDat or SSI serial interfaces can be connected to various interface electronics as well.

Output signals of the interface electronics

The interface electronics are available with the following interfaces to the subsequent electronics:

- TTL square-wave pulse trains
- EnDat 2.2
- DRIVE-CLiQ
- Fanuc Serial Interface
- Mitsubishi high speed interface
- Yaskawa Serial Interface
- PROFIBUS

Interpolation of the sinusoidal input signals

The interface electronics perform signal conversion and interpolate the sinusoidal encoder signals. This permits finer measuring steps and thus higher control quality, as well as superior positioning behavior.

Position value generation

Various interface electronics feature an integrated counting function. Starting from the last set reference point, an absolute position value is generated and output to the subsequent electronics when the reference mark is traversed.

Box design



Plug design



Cable design



Top-hat rail design



Outputs		Inputs		Design – IP rating	Interpolation ¹⁾ or subdivision	Model
Interface	Quantity	Interface	Quantity			
□ TTL	1	~ 1 V _{PP}	1	Box design – IP65	5/10-fold	IBV 101
					20/25/50/100-fold	IBV 102
					Without interpolation	IBV 600
					25/50/100/200/400-fold	IBV 660B
				Plug design – IP40	5/10-fold	IBV 3171
					20/25/50/100-fold	IBV 3271
		~ 11 μA _{PP}	1	Box design – IP65	5/10-fold	EXE 101
					20/25/50/100-fold	EXE 102
□ TTL/ ~ 1 V _{PP} (adjustable)	2	~ 1 V _{PP}	1	Box design – IP65	2-fold	IBV 6072
					5/10-fold	IBV 6172
					5/10-fold and 20/25/50/100-fold	IBV 6272
EnDat 2.2	1	~ 1 V _{PP}	1	Box design – IP65	≤ 16384-fold subdivision	EIB 192
				Plug design – IP40	≤ 16384-fold subdivision	EIB 392
			2	Box design – IP65	≤ 16384-fold subdivision	EIB 1512
DRIVE-CLiQ	1	EnDat 2.2	1	Box design – IP65	–	EIB 2391 S
				Cable design – IP65	–	EIB 3392 S
Fanuc Serial Interface	1	~ 1 V _{PP}	1	Box design – IP65	≤ 16384-fold subdivision	EIB 192 F
				Plug design – IP40	≤ 16384-fold subdivision	EIB 392 F
			2	Box design – IP65	≤ 16384-fold subdivision	EIB 1592 F
Mitsubishi high speed interface	1	~ 1 V _{PP}	1	Box design – IP65	≤ 16384-fold subdivision	EIB 192 M
				Plug design – IP40	≤ 16384-fold subdivision	EIB 392 M
			2	Box design – IP65	≤ 16384-fold subdivision	EIB 1592 M
Yaskawa Serial Interface	1	EnDat 2.2	1	Plug design – IP40	–	EIB 3391 Y
PROFIBUS DP	1	EnDat 2.2	1	Top-hat rail design	–	PROFIBUS Gateway
PROFINET IO	1	EnDat 2.2	1	Top-hat rail design	–	PROFINET Gateway

¹⁾ Switchable

Diagnostics, and inspection and testing equipment

HEIDENHAIN encoders provide all of the information necessary for commissioning, monitoring, and diagnostics. The type of information available depends on whether the encoder is incremental or absolute, and on which interface is being used.

Incremental encoders have 1 V_{PP} TTL, or HTL interfaces. TTL and HTL encoders monitor their signal amplitudes internally and generate a simple fault detection signal. With 1 V_{PP} signals, an analysis of the output signals is possible only with external testing devices or through the expenditure of computation resources in the subsequent electronics (**analog diagnostic interface**).

Absolute encoders employ serial data transmission. Depending on the interface, additional 1 V_{PP} incremental signals can be output. The signals are extensively monitored within the encoder. The monitoring results (particularly valuation numbers) can be transmitted to the subsequent electronics along with the position values via the serial interface (**digital diagnostics interface**).

The following information is available:

- Error message: position value is not reliable
- Warning: an internal functional limit of the encoder has been reached
- Valuation numbers:
 - Detailed information about the encoder's function reserve
 - Identical scaling for all HEIDENHAIN encoders
 - Cyclic reading is possible

The subsequent electronics are able to evaluate the current status of the encoder with little resource expenditure, even during closed-loop operation.

For the analysis of these encoders, HEIDENHAIN offers the suitable PWM inspection devices and PWT testing devices. Based on how these devices are integrated, a distinction is made between two types of diagnostics:

- Encoder diagnostics: the encoder is connected directly to the inspection or testing device, thereby enabling a detailed analysis of the encoder functions.
- Monitoring mode: the PWM inspection device is looped into the closed control loop (via suitable testing adapters if needed). This enables real-time diagnosis of the machine or equipment during operation. The available functions depend on the interface.

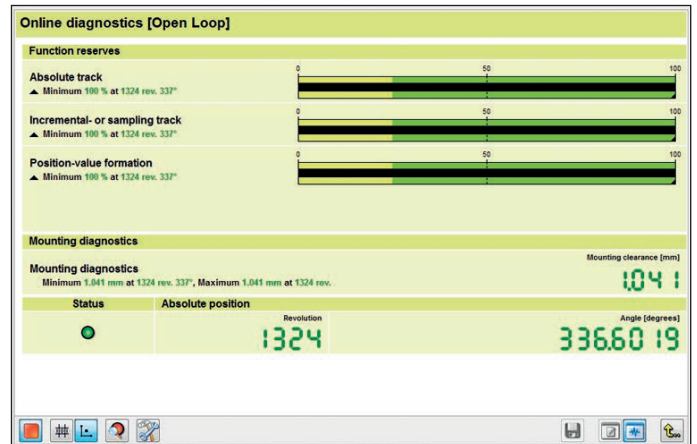

Diagnostics with the PWM 21 and ATS software

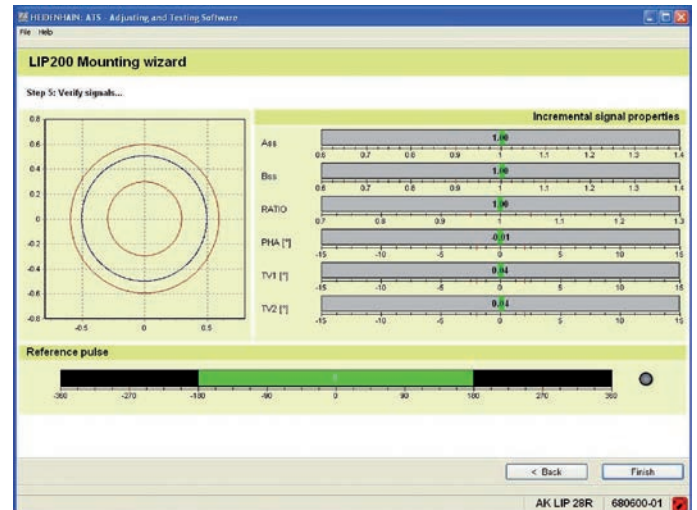

Commissioning with the PWM 21 and ATS software

PWT 101

The PWT 101 is a testing device for the functional testing and adjustment of incremental and absolute HEIDENHAIN encoders. Thanks to its compact dimensions and rugged design, the PWT 101 is ideal for portable use.



	PWT 101
Encoder input only for HEIDENHAIN encoders	<ul style="list-style-type: none"> • EnDat • Fanuc Serial Interface • Mitsubishi high speed interface • Panasonic Serial Interface • Yaskawa Serial Interface • 1 V_{PP} • 11 μA_{PP} • TTL
Display	4.3-inch color flat-panel display (touchscreen)
Supply voltage	DC 24 V Power consumption: max. 15 W
Operating temperature	0 °C to 40 °C
Protection EN 60529	IP20
Dimensions	≈ 145 mm × 85 mm × 35 mm

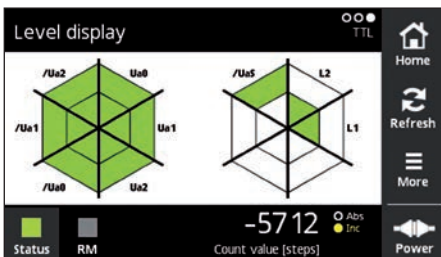

Level display

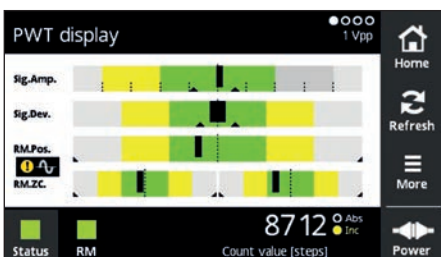

PWT display

PWM 21

The PWM 21 phase-angle measuring device, together with the ATS adjusting and testing software, serves as an adjusting and testing package for the diagnosis and adjustment of HEIDENHAIN encoders.



For more information, please refer to the *PWM 21/ATS Software* Product Information document.

	PWM 21
Encoder input	<ul style="list-style-type: none"> • EnDat 2.1 or EnDat 2.2 (absolute value with or without incremental signals) • DRIVE-CLiQ • Fanuc Serial Interface • Mitsubishi high speed interface • Yaskawa Serial Interface • Panasonic serial interface • SSI • 1 V_{PP}/TTL/11 μA_{PP} • HTL (via signal adapter)
Interface	USB 2.0
Supply voltage	AC 100 V to 240 V or DC 24 V
Dimensions	258 mm × 154 mm × 55 mm

	ATS
Languages	Choice between German and English
Functions	<ul style="list-style-type: none"> • Position display • Connection dialog • Diagnostics • Mounting wizard for EBI/ECI/EQI, LIP 200, LIC 4000, and others • Additional functions (if supported by the encoder) • Memory contents
System requirements and recommendations	PC (dual-core processor > 2 GHz) RAM > 2 GB Operating system: Windows 7, 8, and 10 (32-bit / 64-bit) 500 MB of free hard drive space

DRIVE-CLiQ is a registered trademark of Siemens AG.

HEIDENHAIN

DR. JOHANNES HEIDENHAIN GmbH

Dr.-Johannes-Heidenhain-Straße 5

83301 Traunreut, Germany

☎ +49 8669 31-0

FAX +49 8669 32-5061

E-mail: info@heidenhain.de

www.heidenhain.de

Vollständige und weitere Adressen siehe www.heidenhain.de
For complete and further addresses see www.heidenhain.de

DE	HEIDENHAIN Vertrieb Deutschland 83301 Traunreut, Deutschland ☎ 08669 31-3132 FAX 08669 32-3132 E-Mail: hd@heidenhain.de	ES	FARRESA ELECTRONICA S.A. 08028 Barcelona, Spain www.farresa.es	PL	APS 02-384 Warszawa, Poland www.heidenhain.pl
	HEIDENHAIN Technisches Büro Nord 12681 Berlin, Deutschland ☎ 030 54705-240	FI	HEIDENHAIN Scandinavia AB 01740 Vantaa, Finland www.heidenhain.fi	PT	FARRESA ELECTRÓNICA, LDA. 4470 - 177 Maia, Portugal www.farresa.pt
	HEIDENHAIN Technisches Büro Mitte 07751 Jena, Deutschland ☎ 03641 4728-250	FR	HEIDENHAIN FRANCE sarl 92310 Sèvres, France www.heidenhain.fr	RO	HEIDENHAIN Reprezentantă Romania Braşov, 500407, Romania www.heidenhain.ro
	HEIDENHAIN Technisches Büro West 44379 Dortmund, Deutschland ☎ 0231 618083-0	GB	HEIDENHAIN (G.B.) Limited Burgess Hill RH15 9RD, United Kingdom www.heidenhain.co.uk	RS	Serbia → BG
	HEIDENHAIN Technisches Büro Südwest 70771 Leinfelden-Echterdingen, Deutschland ☎ 0711 993395-0	GR	MB Milionis Vassilis 17341 Athens, Greece www.heidenhain.gr	RU	OOO HEIDENHAIN 115172 Moscow, Russia www.heidenhain.ru
	HEIDENHAIN Technisches Büro Südost 83301 Traunreut, Deutschland ☎ 08669 31-1337	HR	Croatia → SL	SE	HEIDENHAIN Scandinavia AB 12739 Skärholmen, Sweden www.heidenhain.se
AR	NAKASE SRL. B1653AOX Villa Ballester, Argentina www.heidenhain.com.ar	HU	HEIDENHAIN Kereskedelmi Képviselet 1239 Budapest, Hungary www.heidenhain.hu	SG	HEIDENHAIN PACIFIC PTE LTD Singapore 408593 www.heidenhain.com.sg
AT	HEIDENHAIN Techn. Büro Österreich 83301 Traunreut, Germany www.heidenhain.de	ID	PT Servitama Era Toolsindo Jakarta 13930, Indonesia E-mail: ptset@group.gts.co.id	SK	KOPRETINA TN s.r.o. 91101 Trenčín, Slovakia www.kopretina.sk
AU	FCR MOTION TECHNOLOGY PTY LTD Laverton North Victoria 3026, Australia E-mail: sales@fcrmotion.com	IL	NEUMO VARGUS MARKETING LTD. Holon, 58859, Israel E-mail: neumo@neumo-vargus.co.il	SL	NAVO d.o.o. 2000 Maribor, Slovenia www.heidenhain.si
BE	HEIDENHAIN N.V. 1760 Roosdaal, Belgium www.heidenhain.be	IN	HEIDENHAIN Optics & Electronics India Private Limited Chetpet, Chennai 600 031, India www.heidenhain.in	TH	HEIDENHAIN (THAILAND) LTD Bangkok 10250, Thailand www.heidenhain.co.th
BG	ESD Bulgaria Ltd. Sofia 1172, Bulgaria www.esd.bg	IT	HEIDENHAIN ITALIANA S.r.l. 20128 Milano, Italy www.heidenhain.it	TR	T&M Mühendislik San. ve Tic. LTD. ŞTİ. 34775 Y. Dudullu – Ümraniye-Istanbul, Turkey www.heidenhain.com.tr
BR	HEIDENHAIN Brasil Ltda. 04763-070 – São Paulo – SP, Brazil www.heidenhain.com.br	JP	HEIDENHAIN K.K. Tokyo 102-0083, Japan www.heidenhain.co.jp	TW	HEIDENHAIN Co., Ltd. Taichung 40768, Taiwan R.O.C. www.heidenhain.com.tw
BY	GERTNER Service GmbH 220026 Minsk, Belarus www.heidenhain.by	KR	HEIDENHAIN Korea LTD.. Gasam-Dong, Seoul, Korea, 153-782 www.heidenhain.co.kr	UA	Gertner Service GmbH Büro Kiev 02094 Kiev, Ukraine www.heidenhain.ua
CA	HEIDENHAIN CORPORATION Mississauga, Ontario L5T2N2, Canada www.heidenhain.com	MX	HEIDENHAIN CORPORATION MEXICO 20290 Aguascalientes, AGS., Mexico E-mail: info@heidenhain.com	US	HEIDENHAIN CORPORATION Schaumburg, IL 60173-5337, USA www.heidenhain.com
CH	HEIDENHAIN (SCHWEIZ) AG 8603 Schwerzenbach, Switzerland www.heidenhain.ch	MY	ISOSERVE SDN. BHD. 43200 Balakong, Selangor E-mail: sales@isoserve.com.my	VN	AMS Co. Ltd HCM City, Vietnam E-mail: davidgoh@amsvn.com
CN	DR. JOHANNES HEIDENHAIN (CHINA) Co., Ltd. Beijing 101312, China www.heidenhain.com.cn	NL	HEIDENHAIN NEDERLAND B.V. 6716 BM Ede, Netherlands www.heidenhain.nl	ZA	MAFEMA SALES SERVICES C.C. Midrand 1685, South Africa www.heidenhain.co.za
CZ	HEIDENHAIN s.r.o. 102 00 Praha 10, Czech Republic www.heidenhain.cz	NO	HEIDENHAIN Scandinavia AB 7300 Orkanger, Norway www.heidenhain.no		
DK	TPTEKNIK A/S 2670 Greve, Denmark www.tp-gruppen.dk	NZ	Llama ENGINEERING Ltd 5012 Wellington, New Zealand E-mail: info@llamaengineering.co.nz		
		PH	MACHINEBANKS' CORPORATION Quezon City, Philippines 1113 E-mail: info@machinebanks.com		