



HEIDENHAIN

12 ways to optimize your robot design using rotary encoders

The benefits of inductive rotary encoders in robotics

E-BOOK



Contents

Introduction	3
The challenges	3
Finding room with limited space	3
Effects of zero positioning error, reversal error, etc.	4
Finding matching components	4
Predicting real-world operation	4
Keeping functional safety in view	4
Achieving digitalized diagnostics and maintenance	4
Enabling easily automatable assembly	5
Ensuring product quality	5
Staying on schedule	5
12 approaches to better designs	6
Use flat, space-saving designs	7
Make high positioning accuracy easier	7
Flexibly select components	8
Enjoy wide tolerances for real-world operation	8
Enable high dynamic performance	8
Achieve less wear through fewer components	9
Ensure functional safety	9
Enable predictive maintenance and condition monitoring	9
Reduce lead times	10
Make assembly simpler	10
Ensure quality and process reliability	10
Design faster	10
Checklist for selecting a rotary encoder	11
Balancing quality, functionality, and cost	11
Choose comprehensive solutions!	12

Introduction

Rotary encoders are critical components in robot motion control. They continually deliver the accurate speed and position of an axis under harsh conditions. Rotary encoders also compensate for the inaccuracy of other components, ensuring optimal arm motion and positioning. They are the key to a robot's dynamic performance, accuracy, and reliability.

Despite their importance, rotary encoders are often underestimated during the design phase. From a manufacturing perspective, encoder installation needs to be simple and readily automatable. Because robots require multiple rotary encoders, cost is also a factor.

Today's robotics industry places a variety of demands on rotary encoders, and these requirements are growing. End customers expect robots with higher dynamic performance, heavier load capacity, greater accuracy, smaller size, and superior cost efficiency for optimizing their manufacturing processes and realizing new applications. This e-book will explain how robot designers can use inductive rotary encoders to meet these rising demands.

The challenges

The development phase requires important design decisions about how to achieve the desired robot characteristics and meet project requirements. One of the most important characteristics is exact and repeatable positioning. From a design perspective, achieving this without exceeding the cost limit for robot production, including encoder assembly, is a challenge requiring well-designed solutions.

Finding room with limited space

Installation space is always limited in robots, and this is particularly true in compact cobots. Rotary encoders should have the smallest footprint possible, not least because two rotary encoders are often installed per joint for greater accuracy. In this configuration, the motor feedback encoder measures the speed of the motor, while the secondary encoder tracks the actual motion of the robot axis. Both encoders, including their cables, must fit the available space.

Secondary encoders

Robot designers attain much higher absolute positioning accuracy by adding an additional, high-accuracy encoder to each robot axis. These secondary encoders are installed downstream from the gearbox, where they measure the actual position of the robotic joint. This addresses zero position error, reversal error, and the position error of the robot arm at each axis. Depending on the application, the absolute positioning accuracy at the Tool Center Point can be improved by up to 80 percent.



Effects of zero positioning error, reversal error, etc.

Fundamental mechanical effects make it difficult to achieve high positioning accuracy and therefore reliable positioning of the Tool Center Point. Path accuracy is hindered by the zero point error of the robotic joint, the reversal error of the gearbox, and the elasticity of materials under load. These three factors are collectively known as hysteresis. To create robots that weld on-target or accurately insert screws, designers must learn to manage these effects.

Finding matching components

Geometric constraints arise through the choice of components such as the motor, bearings, gearbox, and shaft. Rotary encoders need to be geometrically versatile enough to fit these components or be available in matchable variants. The overall design is then easier to vary and rescale. Rotary encoders should be available both with and without an integral bearing in order to accommodate the anticipated mechanical load and intended application.

Predicting real-world operation

It is crucial to consider how the design will behave under real-world conditions, where small factors can quickly add up to big problems. This is particularly true wherever temperature fluctuations, aging, contamination, and vibrations in the drive train are involved. One solution is to install higher-quality components, but at the risk of jeopardizing budget limitations.

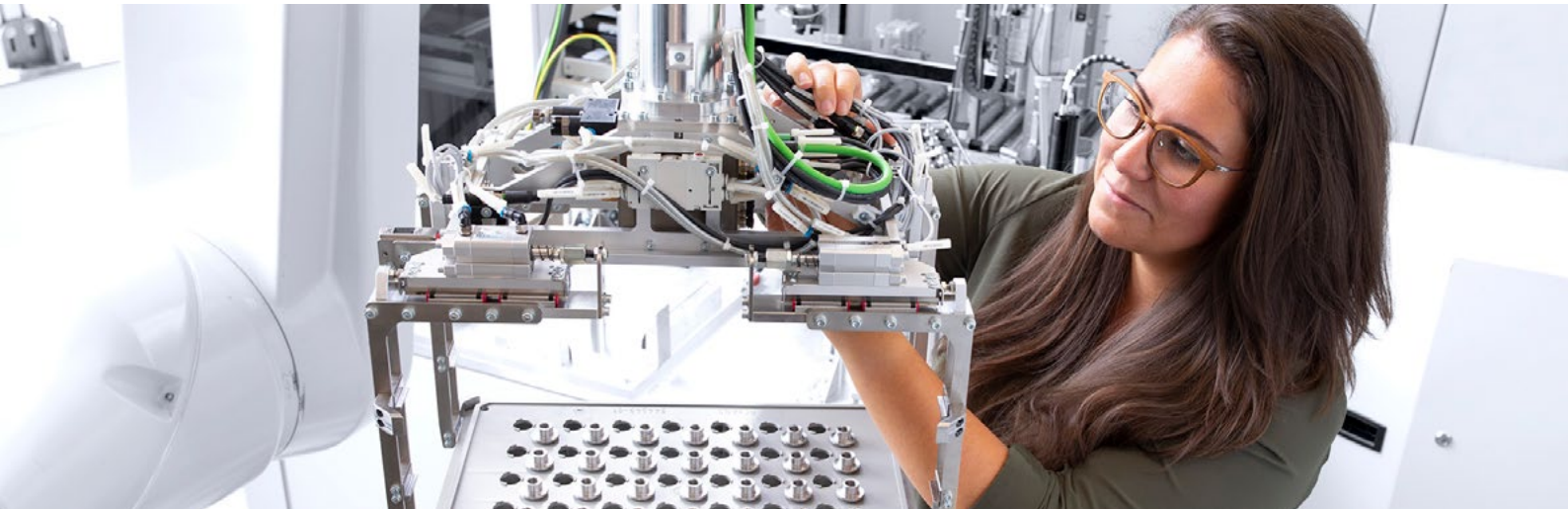

Keeping functional safety in view

Eliminating the risk of personal injury is vital, especially in safety-related applications such as cobots. Any design must demonstrate compliance with the applicable safety standards. Rotary encoders, along with the controller electronics and software, are key safety components due to their role in the speed and acceleration of the robotic arm. More in-house development and higher numbers of parts make it more difficult to comply with functional safety. As part of Industry 4.0, robots are also increasingly expected to contribute to predictive maintenance.

Achieving digitalized diagnostics and maintenance

As Industry 4.0 advances, manufacturing machines will be expected to deliver growing amounts of real-time data through trustworthy interfaces. The goal is to achieve flawless, uninterrupted operation supported by predictive maintenance. Rotary encoders must contribute to this flow of data by providing information about their current condition.

Enabling easily automatable assembly

An estimated 70 percent of production costs arise from decisions made during the design phase. Subsequent changes to the design or manufacturing process become even more costly. Designers must therefore ensure that assembly will be efficient, cost-efficient, and as automatable as possible.

Other factors that affect production costs are the number of installed parts, the number of required work steps, and the necessary level of training.

Ensuring product quality

Detailed quality inspections, particularly 100-percent inspections, increase the cycle time. These should be unnecessary if designers select rotary encoders that have wide mounting tolerances and lend themselves to automated mounting inspection.

Staying on schedule

The amount of project time allocated to design work is limited, often to just a few weeks. This reduces the number of possible design iterations and offers little room for experimentation.

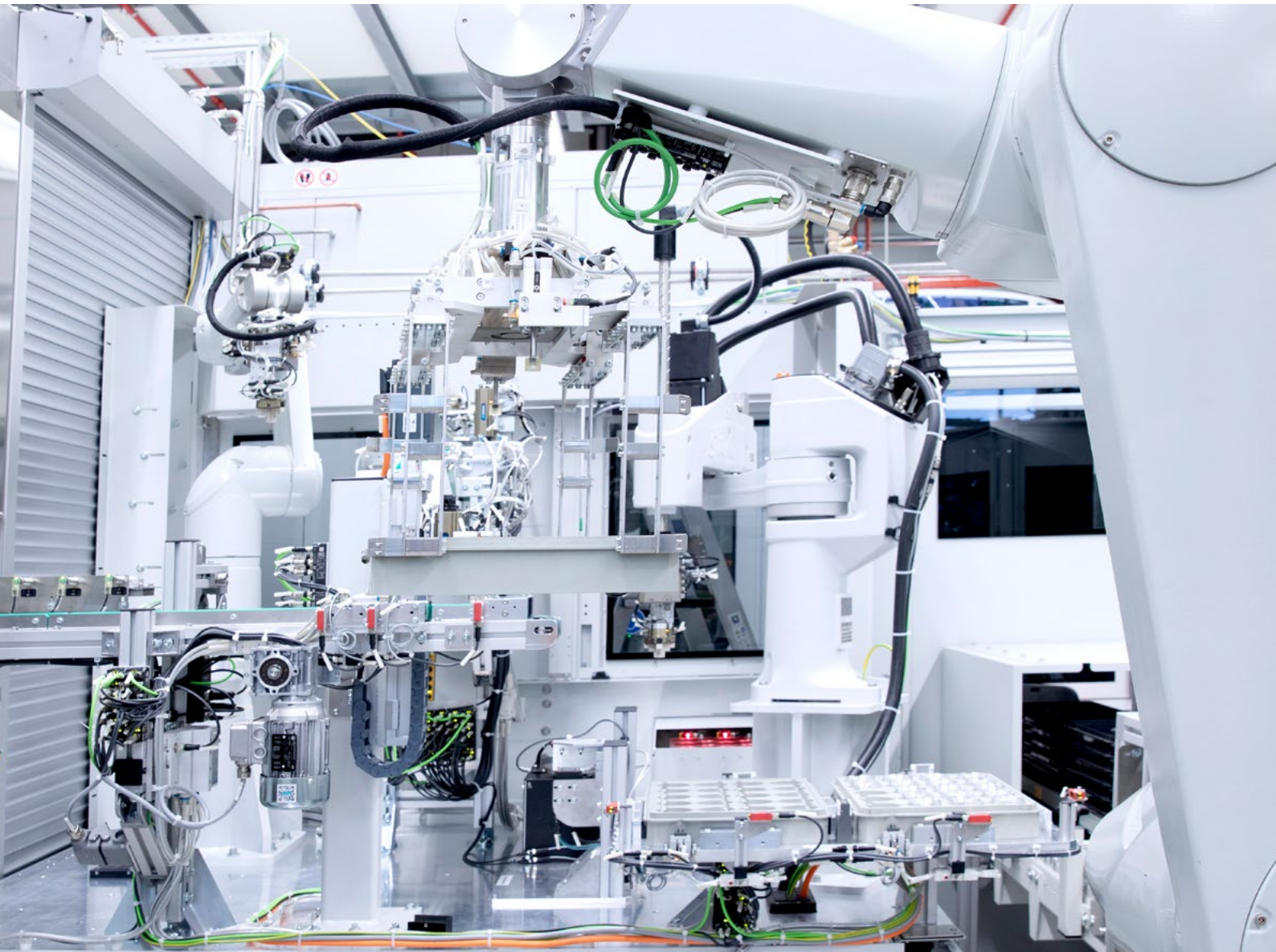

12 approaches to better designs

Robot designers must skillfully juggling a variety of factors. Because robots are such complex systems, many components have a larger impact on the overall system than one might expect. The use of simple, low-cost components can actually make the overall design more complicated, error-prone, and expensive.

Read on to discover how inductive dual encoders from **HEIDENHAIN** allow you to meet the requirements of both robot design and production.

The KCI 120 Dplus combines two hollow-shaft encoders that measure the speed of the motor and the angular displacement of the output axis (and thus the robotic joint). This dual encoder consists of two rotors and a scanning unit mounted between them. The speed-measurement rotor sits on the hollow shaft of the motor, while the position-measurement rotor is attached to the output axis.

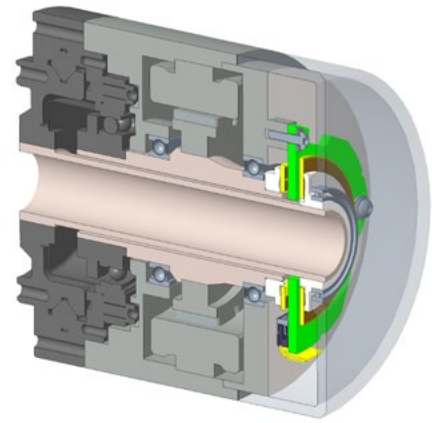

Inductive scanning: the heart of the dual encoder

Inductive rotary encoders use the inductive scanning method. Graduation structures made of copper/nickel are applied to a carrier material for printed circuits. These structures modulate the amplitude and phase of a high frequency signal. Through the course of a revolution, absolute position feedback is generated based on signals from the receiver coils evenly distributed around the circumference.

Absolute position information is available immediately after switch-on, requiring no calibration. Inductive rotary encoders from **HEIDENHAIN** are available in singleturn and multiturn variants.

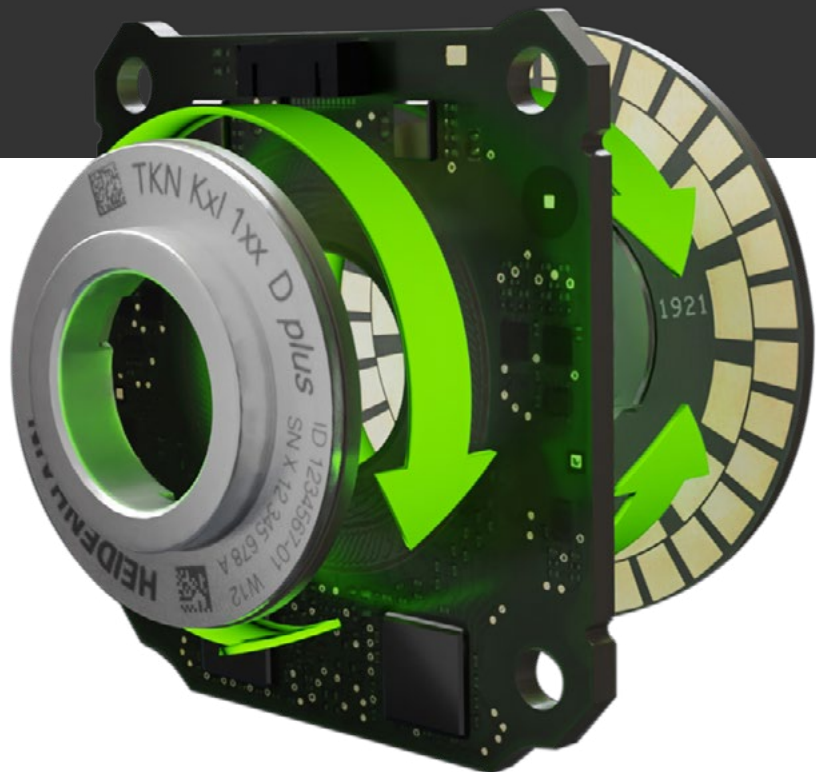

The benefits of inductive scanning

The inductive scanning method is highly resistant to magnetic fields. It also compensates for shaft eccentricity due to loading and other factors. This scanning method also accommodates wide axial mounting tolerances, thus compensating for imperfect mounting and thermal expansion.

The inductive scanning method is highly robust, maintaining high function reserves in the face of humidity, oil mists from motor bearings, and contamination, such as brake dust. In short, this method ensures a high level of fail-safe performance.

Use flat, space-saving designs

The scanning units for the dual encoder's two rotors are contained in a single component: a PCB that accommodates all of the encoder's electronics. It is rigidly mounted to the stator and positioned between the two rotors. This sandwich approach makes dual encoders more compact than conventional rotary encoders, saving at least 15 mm of axial installation space.

Even though it has dual functionality, the encoder needs only one cable and connector, thus saving even more space. In addition, its rotors do not need their own bearing. All of these factors significantly lower the encoder's weight.

Make high positioning accuracy easier

The output-side encoder, equivalent to a secondary encoder, greatly increases the positioning accuracy and repeatability at the Tool Center Point. It compensates for zero position error, reversal error, and joint elasticity. Depending on the application, improvements of up to 80% are possible.

Because each rotor is directly connected to its shaft, and the scanning unit is decoupled from the motor (i.e., output shaft), the system is highly resistant to vibration, thereby excluding overshoots. The highly rigid shaft and stator connections also ensure a very high natural frequency. As a result, the encoder does not hamper the motor's dynamic performance. A separate filter in the speed control loop is unnecessary. The rotor-to-shaft connection is designed to ensure mechanical fault exclusion, a vital feature in applications requiring functional safety.

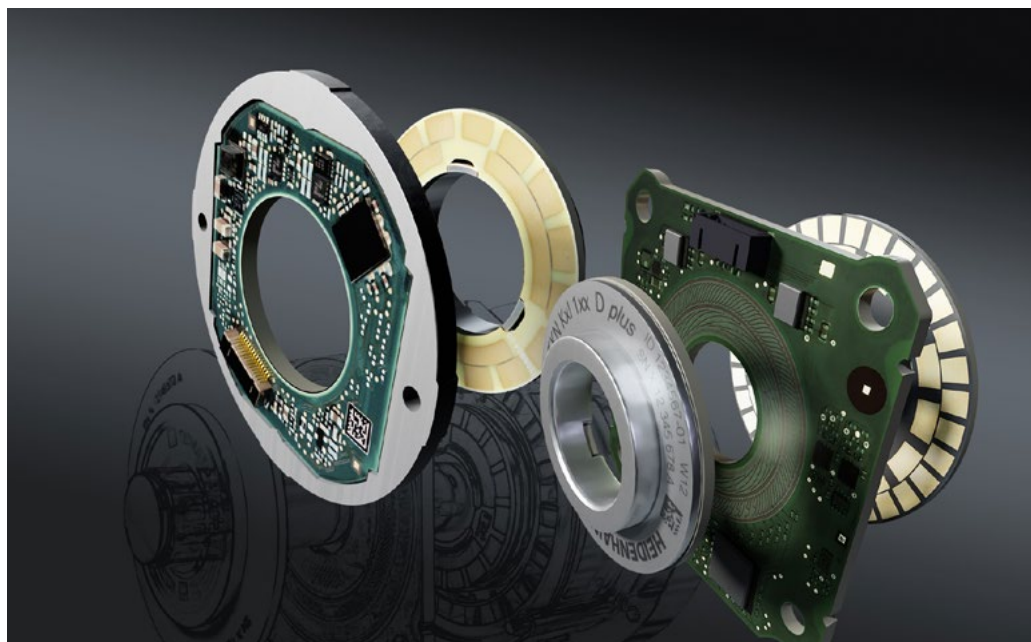

Flexibly select components

Dual encoders from **HEIDENHAIN** are available with various hubs for a wide range of shaft designs. If additional support is required on the output side, a bearing (usually a conventional model) can be press-fitted onto an extended hub. For large orders, specific diameters or geometries can be requested at **HEIDENHAIN**.

Enjoy wide tolerances for real-world operation

The dual encoder's inductive scanning method, compact design, and direct shaft connection can compensate in part for the effects of large, fluctuating measurement deviations. This is particularly noticeable during temperature fluctuations and aging. The encoder excels at handling vibrations in the drive train and allows designers to use less expensive components in other areas without compromising the positioning accuracy.

Enable high dynamic performance

Small increases in speed can add up to significant time savings for end users. An inductive dual encoder from **HEIDENHAIN** weighs only 0.05 kg. The encoder's low mass and rigid rotor connection have a positive effect on the dynamic performance of the mechanical design, allowing the robotic arm to move faster. Low mass is also beneficial in collaborative applications.

The HEIDENHAIN EnDat 22 interface

Rotary encoders from **HEIDENHAIN** are available with a variety of digital interfaces. EnDat is an advanced interface developed by **HEIDENHAIN**. It features high noise immunity and fast digital data transmission. The functional safety version provides a second position value, numerous diagnostic options, motor-specific characteristic values, and sensor data. For more information, visit: endat.de.

Achieve less wear through fewer components

If it's not there, then it can't break. The inductive scanning method requires no LED, photosensor, or bearing. The starting torque is therefore lower and less sensitive to temperature fluctuations (due to the lack of bearing grease). All of this reduces the risk of failure.



Ensure functional safety

In safety-related applications such as cobots, liability risks must be kept to a minimum. The applicable standards, EN ISO 13849-1 (successor to EN 954-1), EN 61508, und EN 61800-5-2 take a modular approach, evaluating safety-related systems based in part on the probability of failure of the integrated components and subsystems. An encoder that has been certified in accordance with these standards simplifies the implementation of a safety-related complete system.

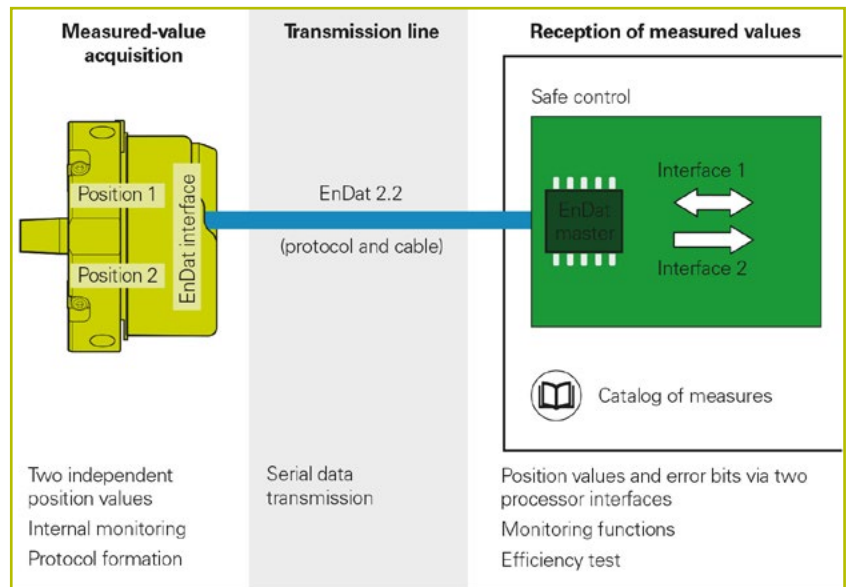

The electronics of **HEIDENAIN** encoders also contribute to the safety of the position measurement system, including two independently generated position values and additional error bits sent to the Master (EnDat 2.2). The Master handles important monitoring functions, detecting any errors in the encoder or data stream.

Enable predictive maintenance and condition monitoring

The dual encoder's inductive scanning method, compact design, and direct shaft connection can compensate in part for the effects of large, fluctuating measurement deviations. This is particularly noticeable during temperature fluctuations and aging. The encoder excels at handling vibrations in the drive train and allows designers to use less expensive components in other areas without compromising the positioning accuracy.

Enable high dynamic performance

Intelligent electronics turn **HEIDENHAIN** encoders into information-sharing devices: components with an advanced interface can deliver extensive condition data such as error messages, warnings, and online diagnostics based on valuation numbers. This in turn enables the implementation of detailed diagnostics for the complete system. When combined with state-of-the-art analyses, this facilitates rapid troubleshooting and predictive maintenance. Regularly triggered tests also check the encoder's health.

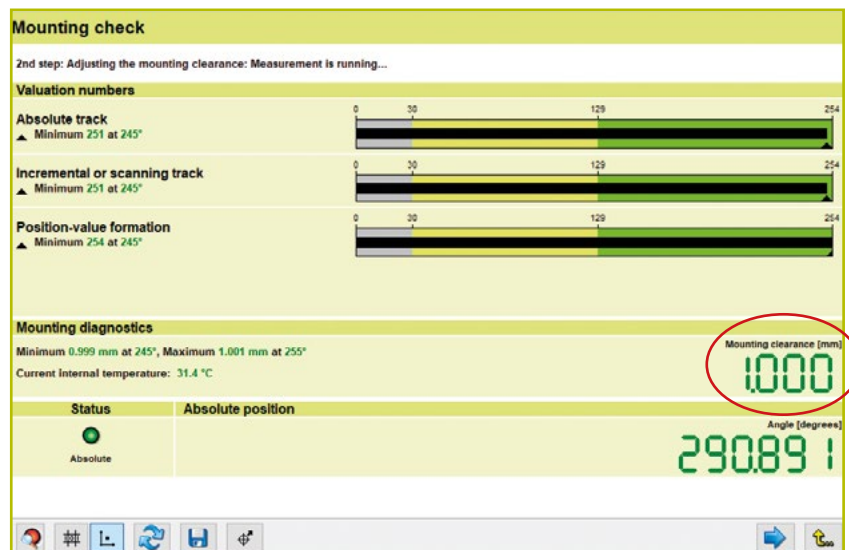

Reduce lead times

Easily automatable assembly methods have a positive effect on lead times. The press-fitting method for attaching the dual encoder's rotors has benefits over screw fastening or screw clamping methods.

Assembly is made even easier thanks to the encoder's built-in electronics, which can compensate for imperfect mounting distances between the rotors and the scanning unit. And since the two encoders share a single connecting cable, one entire work step is saved.

Make assembly simpler

The more demanding an assembly step is, the more training employees need. Dual encoders from **HEIDENHAIN** require no specific rotor orientation on the shaft, and the three encoder parts have no prescribed pairing, making assembly simple. The parts can be provided for assembly without any indication of their orientation. Meanwhile, the press-fitting process eliminates the need for screws and facilitates automation. Less overall training is therefore needed for assembly.

Ensure quality and process reliability

HEIDENHAIN bearingless encoders are available with electronic mounting diagnostics that immediately determine whether the system is correctly installed and operational. In the case of **HEIDENHAIN** dual encoders, the interface indicates whether the three parts have been mounted to within the permissible spacing tolerances.

Intelligent rotary encoders have other beneficial features as well. Some models require no calibration run, making them immediately operable after mounting, for mount-and-play functionality.

Some models also feature an electronic ID label that can be accessed through the interface, providing access to ID numbers and serial numbers. In a rewritable, non-volatile memory area, the installer can also store his own data, including operating parameters, test results (fault-proof mounting), a robot serial number, and the date of production, thus enabling automated setup.

Design faster

Robot design is no longer a new field, and the development of new models is subject to strict deadlines. The use of functional safety-certified dual encoders saves designers detail work and simplifies safety documentation. These benefits speed up design time and reduce the number of setbacks caused by errors.



Checklist for selecting a rotary encoder

If components and characteristics have already been specified from the outset, then the following questions can help designers home in on their ideal rotary encoder solution:

- **Cost:** Which aspects of your design and assembly process could benefit from the KCI 120 Dplus?
- **Method of operation:** Are there ambient conditions that require the inductive scanning principle (magnetic fields, dust, or humidity)?
- **Functional safety:** Does the rotary encoder come with certifications that make it easy to verify the design's safety?
- **Installation space:** Does the compact design of a dual encoder provide space-saving benefits over conventional rotary encoders?
- **Mounting:** Can the individual parts be mounted free of error and without extensive training?
- **Flexibility:** Is the rotary encoder available in multiple variants with regard to size, resolution, etc., so that the design can be readily varied and rescaled?
- **Tolerances:** To what extent can the rotary encoder compensate for reversal error and elasticity (hysteresis)? Does the encoder permit the use of low-cost parts such as bearings, gear boxes, etc.?
- **Lead time:** Is the mounting process simple and at least partially automatable?
- **Quality assurance:** Does the rotary encoder provide information for verifying correct mounting and functionality?

Balancing quality, functionality, and cost

By the beginning of the design phase, the budget and certain components have often already been defined. But designers still enjoy a degree of leeway as long as their decisions are justifiable and approvable by the project manager.

If designers can show that inductive dual encoders from **HEIDENHAIN** do not ultimately raise system costs and may even lower them, then they have a solid argument. Thanks to the wide tolerances inherent in the design and scanning method of these encoders, lower-cost components can be used elsewhere (for bearings, shafts, and gearboxes),

Integrated components and an intelligent interface can also reduce design time and controller programming effort, thus providing additional arguments.

Even if these encoders were to exceed production cost limits, the overall design would still benefit from improved functional safety, function reserves, positioning accuracy, and total cost of ownership, thus securing a market advantage.



Choose comprehensive solutions!

Designers are skilled at managing practical limitations. Selecting an intelligent, high-quality rotary encoder enables elegant robot designs that still meet precision, cost, and safety requirements.

HEIDENHAIN strives to support these kinds of solutions with its products, prides itself on being a reliable supplier, and provides extensive support to designers and programmers. Our products and services are valued by customers around the world.

Please contact us! We look forward to helping you tackle your technical challenges.



HEIDENHAIN

DR. JOHANNES HEIDENHAIN GmbH
Dr.-Johannes-Heidenhain-Straße 5
83301 Traunreut, Germany
+49 8669 31-0
+49 8669 32-5061
E-Mail: info@heidenhain.de

www.heidenhain.de